



**WOOD
TOUCHED
BY LIGHT**

HISTORY

In 2020, we'll celebrate twenty-five years at LZF. Our journey has been an exploration of light, love and life. During this time we've experienced our share of hard work, some has given better results than others but it has always brought us experiences that help us improve in the long run. Recently, we took a step back, reflecting on our way of working and our aspirations, making some much-needed changes. Our core values remain the same, but we've shaken things up: we have new lamps, new materials, new people and new designers, and we feel heady with excitement.

Comprising more than twenty-five lighting fixtures, LZF's new collection is both diverse and discerning. We set the bar high and we rose to meet it, in many ways exceeding our own expectations - we are proud of the results. Design and collaboration with creatives and artists from a range of sectors played a crucial role in the new collection, but they are also key aspects of our philosophy. Design is about a shared experience, one that recognises a common sensibility, a perceptiveness. Moreover, at LZF we see design as a cause. The source behind many of our processes, we aim to utilise design wherever possible: in the products we develop, in how we show them at fairs and in our corresponding communication campaigns. Design is a fundamental and essential part of the LZF experience.

At LZF we are always mindful of efficiency and sustainability, of innovation and longevity. We know that product design is about a complete experience and we're working hard to meet your expectations. But more than this, we know that light is an integral part of our lives, intimately connected with our emotions and feelings. In the pages of this catalogue, we hope you will take pleasure in our new lamps. They are a physical expression of everything that LZF stands for and they mark a new chapter in the company's journey.

NATURAL WOOD MEANS NATURAL LIGHT

Timberlite™



The mark of
responsible forestry

Wood is a noble material and has been part of our DNA since our beginnings. All LZF lamps are handmade from FSC natural wood veneer, ensuring their origin from controlled forests and guaranteeing our sustainability and environmental commitment. LZF lamps' wood veneers are treated with a technique patented by LZF, called Timberlite®, that allows this fragile material to become flexible and resistant without the need of any chemical processes. Knots and other elements of wood are a natural occurrence and form part of the feel and design of the material. As a living material our veneers will age with time, changing as you change, accompanying you with their richness during a whole lifetime.

ON



OFF



CONTENTS

INDEX	10		
--------------	-----------	--	--

NEW COLLECTION	14		
Black Note	16		
Thesis	30		
Skyline	38		
Lens	46		
Loop	52		
Lola	56		

THE COLLECTION	66		
Agatha	68		
Air	74		
Banga	78		
Candelabro	82		
Carambola	86		
Cervantes	90		
Mini Chou	96		
Chou	100		
Cuad	106		
Dandelion	110		
Domo	114		
Escape	118		
Gea & Cosmos	122		
Guijarro	130		
Hi-Collar	134		
Hide & Seek	138		
I-Club	142		
Icon	150		
Link	154		
MiniMikado	162		
New Wave	168		
Nut	172		
Orbit	176		
Paisley	180		
Piknik	184		
Pleg	188		
Poppy & Pod	192		
Raindrop	196		
Saturnia	200		
Spiro	204		
Stitches	210		
Swirl	214		
Totem	218		
X-Club	222		

LIFE SIZE	226		
Big Bird	228		
The Walking Fish	232		
Smelly Fant	236		
Koi & Kogoi	240		

NATURAL TIMBER VENEER	246		
------------------------------	------------	--	--

METAL FINISHES	250		
-----------------------	------------	--	--

DESIGNERS	252		
------------------	------------	--	--

INDEX

1

SUSPENSION



AGATHA SMALL 68
Suspension



AGATHA LARGE 68
Suspension



AGATHA BALL 68
Suspension



LOLA 56
Suspension, Table & Floor



MINIMIKADO 162
Suspension



NEW WAVE 168
Suspension



NUT 172
Suspension



BANGA 78
Suspension



BLACK NOTE 16
Keys / Suspension,
Floor & Wall



BLACK NOTE 16
Triplet / Suspension,
Floor & Wall



CANDELABRO 82
Suspension



POD 192
Suspension



POPPY 192
Suspension



RAINDROP 196
Suspension



SATURNIA 200
Suspension



CARAMBOLA 86
Suspension



CERVANTES 90
Suspension & Ceiling



CHOU 100
Suspension & Table



CUAD 106
Suspension



SKYLINE 38
Suspension, Table
& Wall



SPIRO 204
Suspension



STITCHES 210
Bamako / Suspension



STITCHES 210
Tombuctú / Suspension



DANDELION 110
Suspension



DOMO 114
Suspension



ESCAPE 118
Suspension



GEA 122
Susp., Floor, Wall &
Ceiling



SWIRL 214
Suspension



TOTEM 218
Suspension



X-CLUB 222
Suspension & Ceiling



HIDE & SEEK 138
Suspension & Wall



I-CLUB 142
Susp., Table, Wall
& Ceiling



ICON 150
Suspension



LINK 154
Suspension & Floor



BIG BIRD 228
Suspension



WALKING FISH 232
Floor



SMELLY FANT 236
Floor



KOI & KOGOI 240
Suspension

2

LIFE SIZE

INDEX

3

TABLE



AIR 74
Table & Wall



CHOU 100
Suspension & Table



CHOU 100
Suspension & Table



I-CLUB 142
Susp., Table, Wall & Ceiling



LOLA 56
Suspension, Table & Floor



LOLA LUX 56
Table



LOOP 52
Table



LENS 46
Table & Floor



LENS 46
Table & Floor



SKYLINE 38
Suspension, Table & Wall



THESIS 30
Table, Floor & Wall

4

FLOOR



BLACK NOTE 16
Triplet / Suspension,
Floor & Wall



COSMOS 122
Susp., Floor, Wall &
Ceiling

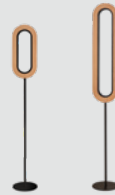

LENS 46
Table & Floor



LINK 154
Suspension & Floor



LOLA 56
Suspension, Table & Floor



PAISLEY 180
Screen



THESIS 30
Table, Floor & Wall

5

CORDLESS



MINI CHOU 96
Table



PIKNIK 184
Table

6

WALL & CEILING



AIR 74
Table & Wall



BLACK NOTE 16
Duplet / Suspension,
Floor & Wall



CERVANTES 90
Suspension & Ceiling



GEA 122
Susp., Floor, Wall &
Ceiling



GUIJARRO 130
Wall & Ceiling



GUIJARRO 130
Wall & Ceiling



GUIJARRO 130
Wall & Ceiling



HI-COLLAR 134
Wall

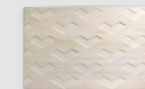

HIDE & SEEK 138
Suspension & Wall



I-CLUB 142
Suspension, Table,
Wall & Ceiling



ORBIT 176
Wall



PLEG 188
Wall



SKYLINE 38
Suspension, Table & Wall



THESIS 30
Table, Floor & Wall



X-CLUB 222
Suspension & Ceiling

NEW
COLLEC
TION

B L A C K N O T E

Designed by:
Ramón Esteve Estudio

Black Note

Keys
Triplet
Duplet

Suspension
Susp. & Floor
Wall

Designed by Ramón Esteve, Black Note is a lamp with perpendicular shades that rise and fall in harmony. Its rhythmic arrangement is inspired by the black keys on a piano, whose sharp and flat notes add emotion and passion to a melody.

Black note's metal frame in our new metallic finishes work, works harmoniously with its luminous, warm wood veneer shades. Ramón Esteve created three Black Note compositions: Black Note Keys (horizontal), Black Note Triplets (suspension & floor) and Black Note Duplets (wall). These differing compositions, with their rhythmic forms, offer a symphony of light, texture and pattern.

• BLACK NOTE KEYS - SUSPENSION

20 Ivory White Wood Veneer & Matt Black Metal Structure & Canopy.
"Casa en la Huerta". Valencia, Spain. Architect: Ramón Esteve Estudio.

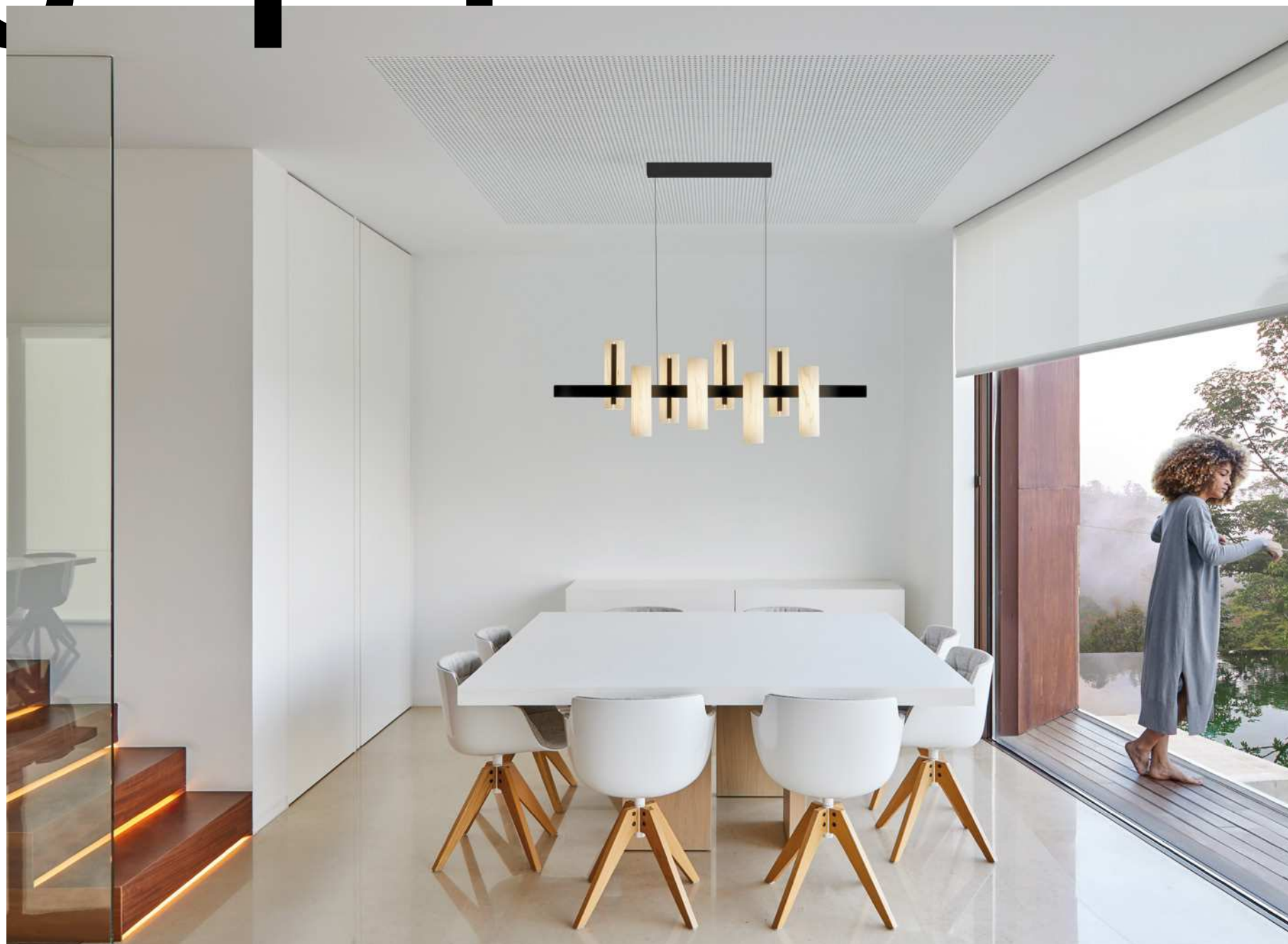



● **BLACK NOTE KEYS - SUSPENSION**

22 Natural Beech Wood Veneer & Gold Metal Structure & Canopy.

The Black Note Keys has dual electrical circuits. Both circuits can be dimmed independently of one another making an almost infinite combination of light blends possible.



● **BLACK NOTE KEYS - SUSPENSION**
21 Natural Cherry Wood Veneer & Matt Black Metal Structure & Canopy.

KEYS

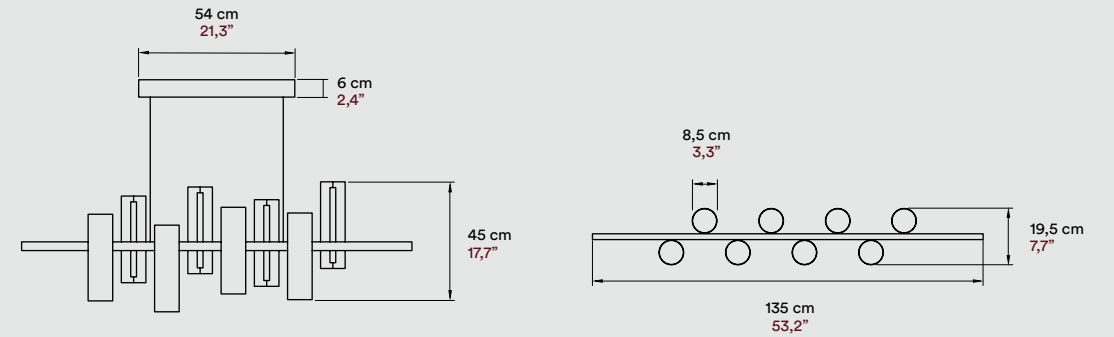

MATERIALS & COMPONENTS

8 Wood Veneer Shades

Metal Structure & Canopy

4 Electrified Steel Cables

2 m drop 8 ft drop

LIGHT SOURCE

Dual Circuit - DC. Enables independent dimming and control of the wood shades and the downlight

120 - 277V
LED Integrated
Dimmable 0-10V, Bluetooth or DALI



120 - 277V
LED Integrated
Dimmable 0-10V & TRIAC







FINISHES

WOOD VENEER

- | | |
|---|--|
|  20 Ivory White |  22 Natural Beech |
|  21 Natural Cherry |  29 Grey |

METAL

- | | |
|--|---|
|  Matt Ivory |  *Black Nickel |
|  Matt Black |  *Gold |

*On Request



● **BLACK NOTE TRIPLET - SUSPENSION**
 20 Ivory White Wood Veneer & Matt Black Metal Structure & Canopy.
 "Casa en la Huerta". Valencia, Spain. Architect: Ramón Esteve Estudio.

TRIPLET

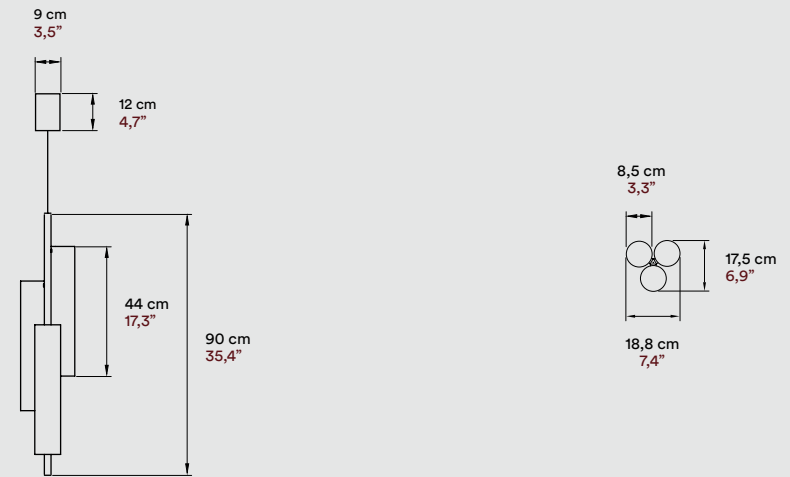

MATERIALS & COMPONENTS

3 Wood Veneer Shades

Metal Structure & Canopy

Electrical Cable
 2 m drop 8 ft drop

LIGHT SOURCE

120 - 277V
 LED Integrated
 Dimmable 0-10V, Bluetooth or DALI



120 - 277V
 LED Integrated
 Dimmable 0-10V & TRIAC



FINISHES

WOOD VENEER

- 20 Ivory White
- 22 Natural Beech
- 21 Natural Cherry
- 29 Grey

METAL

- Matt Ivory
- *Black Nickel
- Matt Black
- *Gold
- *Copper
- *On Request



● **BLACK NOTE TRIPLET - SUSPENSION**
20 Ivory White & 22 Natural Beech Wood Veneer with Ivory White & Copper Metal Structure.

● **BLACK NOTE TRIPLET - SUSPENSION**
29 Grey & 21 Natural Cherry Wood Veneer with Ivory Gold & Black Nickel Metal Structure.



● **BLACK NOTE TRIPLET - FLOOR**
 20 Ivory White Wood Veneer & Matt Black Metal Base.
 "Casa en la Huerta". Valencia, Spain. Architect: Ramón Esteve Estudio.

TRIPLET

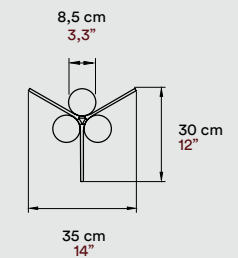
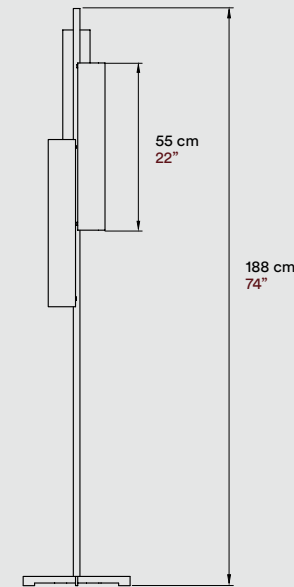

MATERIALS & COMPONENTS

3 Wood Veneer Shades

Metal Stem & Base

Electrical Cable with Dimming Switch
 185 cm 53"

LIGHT SOURCE

230V
 LED Integrated Dimmable

Class I CE

120 V
 LED Integrated Dimmable

cULUS

FINISHES

WOOD VENEER

- 20 Ivory White
- 22 Natural Beech
- 21 Natural Cherry
- 29 Grey

METAL

- Matt Ivory
- *Black Nickel
- Matt Black
- *Gold
- *Copper
- *On Request



● **BLACK NOTE DUPLET - WALL**
 29 Grey Wood Veneer & Matt Black Metal Back Plate. Photo: 4000k.
 "Casa en la Huerta". Valencia, Spain. Architect: Ramón Esteve Estudio.

BLACK NOTE

WALL

RAMÓN ESTEVE ESTUDIO

DUPLET

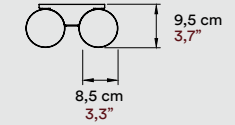
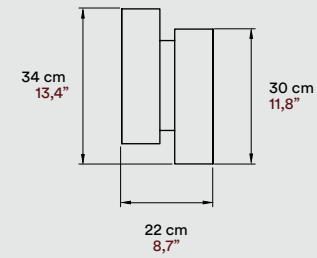

MATERIALS & COMPONENTS

2 Wood Veneer Shades

Metal Back Plate

FINISHES

WOOD VENEER

- 20 Ivory White
- 22 Natural Beech
- 21 Natural Cherry
- 29 Grey

LIGHT SOURCE

120 - 277V
 LED Integrated
 Dimmable 0-10V

Class I

120 - 277V
 LED Integrated
 Dimmable 0-10V & TRIAC

METAL

- Matt Ivory
- *Black Nickel
- Matt Black
- *Gold
- *Copper

*On Request

ADA Compliant

THESIS

Thesis

Floor
Table
Wall

Designed by:
Ramón Esteve Estudio

Thesis is a table lamp and a floor lamp. It is a modern lamp whose companionship is close and intimate, casting a warm glow as you toil through the night, and by your side as you read or simply contemplate the day. Designed by Ramón Esteve, the Thesis lamp is well suited to quiet spaces: in a library, private study or cosy corner, its minimal form and clean lines are free from distraction.

In creating Thesis, a modest metallic base holds a wood veneer shade in its three prongs. Each prong contains an LED that diffuses light downwards, while casting a radiance that quietly highlights the natural timber veneer. In profile, is authoritative and introspective, a quiet light with a smart, introverted personality.

● **THESIS - FLOOR**

20 White Wood Veneer & Copper Metal Base.

"Casa en la Huerta". Valencia, Spain. Architect: Ramón Esteve Estudio.





● **THESIS - TABLE**
 29 Grey Wood Veneer & Matt Black Metal Base.
 Photo: 4000k. "Casa en la Huerta". Valencia, Spain.
 Architect: Ramón Esteve Estudio.



● **THESIS - TABLE**
 29 Grey Wood Veneer & Matt Black Metal Base.
 Photo: 4000k. "Casa en la Huerta". Valencia, Spain.
 Architect: Ramón Esteve Estudio.

THESIS

FLOOR & TABLE

RAMÓN ESTEVE ESTUDIO

FLOOR

TABLE

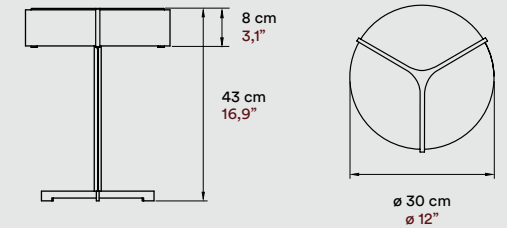
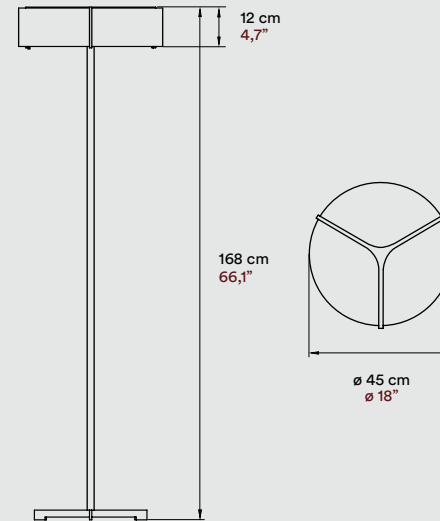

MATERIALS & COMPONENTS

Wood Veneer Shade

Metal Tripod, Stem & Base

Electrical Cable with Dimming Switch

FLOOR 185 cm 53"

TABLE 145 cm 57"

LIGHT SOURCE

230V
LED Integrated Dimmable

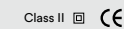

120V
LED Integrated Dimmable



FINISHES

FLOOR WOOD VENEER SHADE

● 20 Ivory White

TABLE WOOD VENEER SHADES

● 20 Ivory White

● 22 Natural Beech

● 21 Natural Cherry

● 29 Grey

METAL

● Matt Ivory

*On Request

● Matt Black

*Black Nickel

*Gold

*Copper



• THESIS - FLOOR & TABLE | 20 White Wood Veneer & Matt Ivory Metal Base. "Casa en la Huerta". Valencia, Spain. Architect: Ramón Esteve Estudio.



● **THESIS - WALL**
 29 Grey Wood Veneer & Matt Black Metal Structure. Photo: 4000k.
 "Bouet" Restaurant. Valencia, Spain. Architect: Ramón Esteve Estudio.

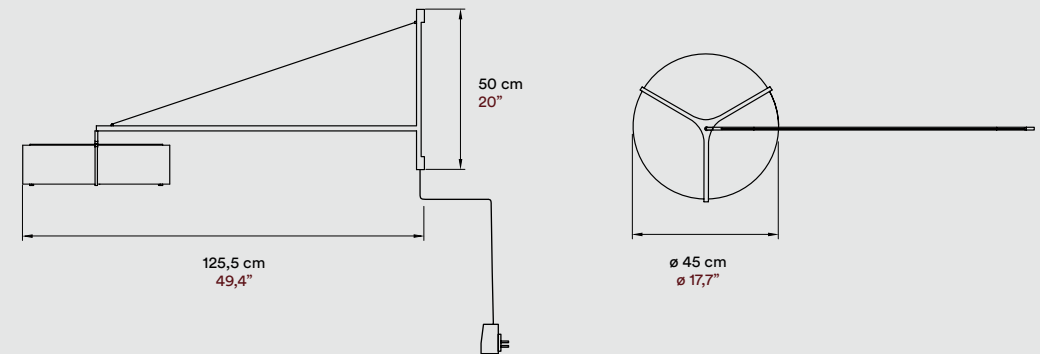

MATERIALS & COMPONENTS

Wood Veneer Shade

Metal Tripod & Structure

Electrical Cable with Dimming Switch
 85 cm 53"

LIGHT SOURCE

230V
 LED Integrated Dimmable

Class II

120V
 LED Integrated Dimmable

FINISHES

WOOD VENEER

- 20 Ivory White
- 22 Natural Beech
- 21 Natural Cherry
- 29 Grey

METAL

- Matt Ivory
 - Matt Black
 - *Black Nickel
 - *Gold
 - *Copper
- *On Request

SKYLINE

Skyline

Suspension
Wall
Table

Designed by:
estudi{H}ac

Created by estudi{H}ac, Skyline is tailor-made using layers of several distinct materials: natural wood veneer, wire mesh and etched acrylic glass. The lamp diffuses light via a carefully arranged skyline of colours, textures and shadows. With a focus on detail, shapes and materials, estudi{H}ac has woven its concept of tailored elegance into the fabric of Skyline.

Skyline is designed to swivel: facing either upwards or downwards, the outline of layered, decorative shapes provides an ambient glow, while the horizontal base shines a direct upward or downward light. A truly novel and inventive lamp, Skyline's use of different materials marks a new direction for LZF.

● **SKYLINE - SUSPENSION**
20 White Wood Veneer, Matt Ivory Perforated Metal & Matt Ivory Metal Base.





● **SKYLINE - SUSPENSION**
22 Natural Beech Wood Veneer, Gold Perforated Metal & Gold Metal Base.

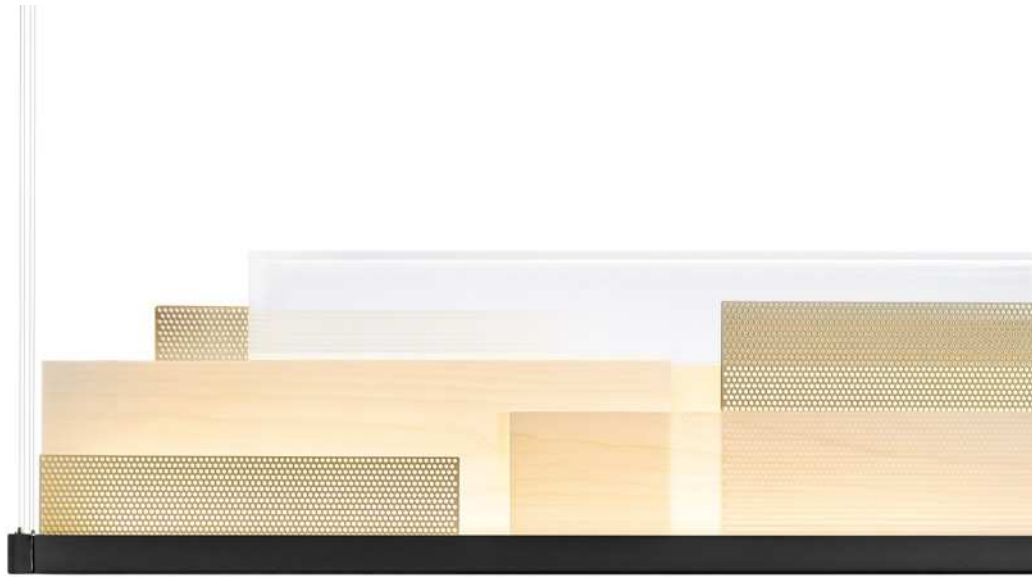

- **SKYLINE - SUSPENSION**
20 White Wood Veneer, Matt Ivory Perforated Metal & Matt Black Metal Base.



- **SKYLINE - SUSPENSION**
22 Natural Beech Wood Veneer, Gold Perforated Metal & Gold Metal Base.

The Skyline suspension has a dual electric circuit that allows for independent control of the technical downlight and the ambient light. It also can be swivelled 180° so that the ambient light can either be facing upwards or downwards.

SKYLINE

SUSPENSION

ESTUDI{H}AC

POSITION 1

POSITION 2

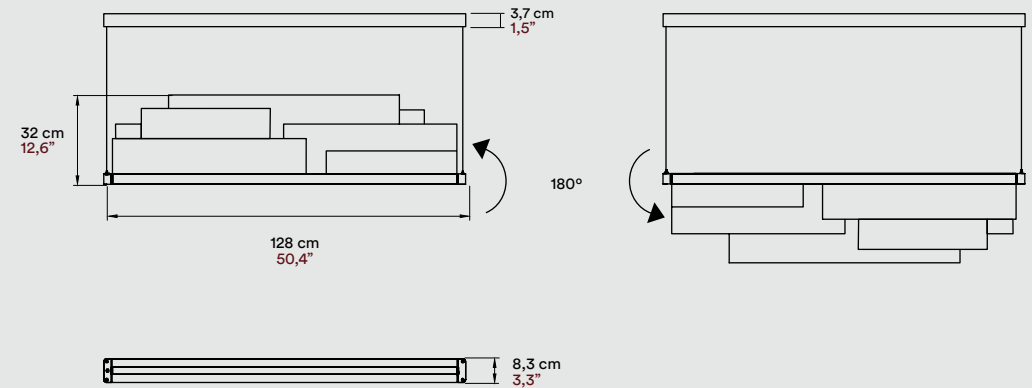

MATERIALS & COMPONENTS

Multimaterial Shade
Wood Veneer, Perforated Metal & Textured Glass

Metal Structure, Perforated Metal & Canopy

4 Steel Cables
2 m drop 8 ft drop

4 Electrified Steel Cables
2 m drop 8 ft drop

LIGHT SOURCE

Dual Circuit - DC. Enables independent dimming and control of the wood shades and the downlight

120 - 277V Class I
LED Integrated
Dimmable 0-10V, Bluetooth or DALI

120 - 277V
LED Integrated
Dimmable 0-10V & TRIAC

FINISHES

WOOD VENEER

- 20 Ivory White
- 22 Natural Beech

PERFORATED METAL

- Matt Ivory with 20 Wood Veneer
- Gold with 22 Wood Veneer

METAL

- Matt Ivory
- *Black Nickel
- Matt Black
- *Gold

*On Request

- **SKYLINE - WALL**
20 White Wood Veneer, Gold Perforated Metal & Gold Metal Base.



- **SKYLINE - TABLE**
20 White Wood Veneer, Matt Ivory Perforated Metal & Black Nickel Metal Base.
"Cosin" Workspace. Valencia, Spain.



SKYLINE

TABLE & WALL

ESTUDI{H}AC

TABLE

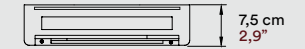
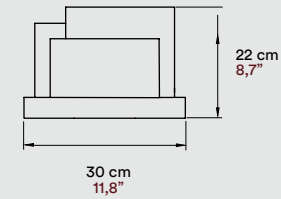

WALL

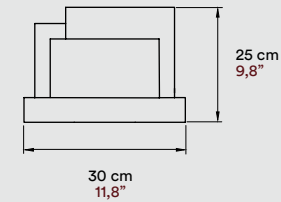

MATERIALS & COMPONENTS

Multimaterial shade

Wood Veneer, Perforated Metal & Textured Glass

Metal Structure, Perforated Metal & Back Plate or Base

Electrical Cable with Dimming Switch

TABLE 145 cm 57"

LIGHT SOURCE

TABLE

230V
LED Integrated Dimmable

Class II

120V

LED Integrated Dimmable

US

WALL

Dual Circuit - DC. Enables independent dimming & control of the shade and the downlight

120 - 277V

LED Integrated Dimmable 0-10V

Class II

120 - 277V

LED Integrated Dimmable 0-10V & TRIAC

US

ADA Compliant

FINISHES

WOOD VENEER

20 Ivory White 22 Natural Beech

PERFORATED METAL

Matt Ivory with 20 Wood Veneer Gold with 22 Wood Veneer

METAL

Matt Ivory *Black Nickel
 Matt Black *Gold

*On Request

LENS

Lens

Floor
Table

Designed by:
Mut Design



- **LENS**
33 Pale Rose Wood Veneer & Copper Metal Structure.

Designed by MUT, Lens enjoys flowing lines with no hard edges. Its wood veneer shade surrounds an oval circumference of light, and in its centre is a clear void. The shade is connected to a slender metallic base. Available as a table and floor lamp, Lens has two shade types: circular and elliptic. The elliptic version has two shapes: an elongated ellipse and a truncated ellipse.

Free from interruption, Lens's radiant light traces the air. Perfectly symmetrical and sleek, soothing and suave, Lens is one smooth luminaire.



- **LENS - FLOOR SUPER OVAL & OVAL**
21 Natural Cherry Wood Veneer & Matt Black Metal Structure. "Casa en la Huerta". Valencia, Spain. Architect: Ramón Esteve Estudio.



● **LENS - TABLE OVAL**
20 Ivory White Wood Veneer & Gold Metal Structure. "Casa en la Huerta". Valencia, Spain. Architect: Ramón Esteve Estudio.



● **LENS - TABLE CIRCULAR**
 20 Ivory White Wood Veneer & Copper Metal Structure.
 "Bouet" Restaurant. Valencia, Spain. Architect: Ramón Esteve Estudio.

LENS

FLOOR & TABLE

MUT DESIGN

FLOOR OVAL

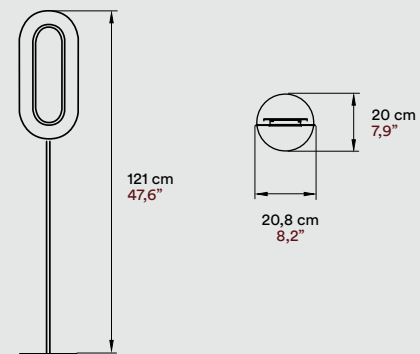

FLOOR SUPER OVAL

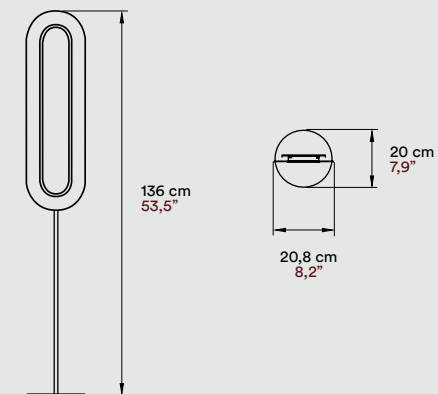

TABLE CIRCULAR

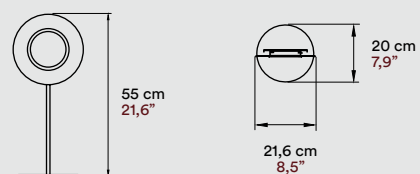
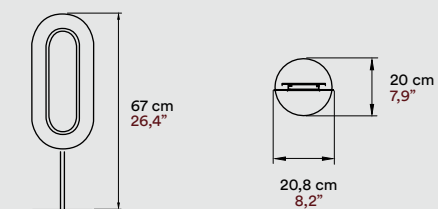

TABLE OVAL



MATERIALS & COMPONENTS

Wood Veneer Shade

Metal Ring, Stem & Base

Electrical Cable with Dimming Switch

FLOOR 185 cm 53"

TABLE 145 cm 57"

FINISHES

WOOD VENEER

- 20 Ivory White
- 28 Blue
- 21 Natural Cherry
- 29 Grey
- 22 Natural Beech
- 33 Pale Rose

LIGHT SOURCE

230V
 LED Integrated Dimmable.
 Dim to warm



120V
 LED Integrated Dimmable.
 Dim to warm



METAL

- Matt Ivory
- *Black Nickel
- Matt Black
- *Gold
- *On Request
- *Copper

LOOP

Loop

Designed by:
Mut Design

• **LOOP - TABLE**
22 Natural Beech Wood Veneer & Gold Metal Structure.

In a style reminiscent of the classic roller coaster vertical loop or the old loop tracks for racing toy cars, the Loop lamp is instantly familiar. Designed by MUT, Loop enjoys flowing lines with no hard edges. Its wood veneer shade surrounds a looping LED and is connected to a slender metallic base.

Free from interruption, Loop's radiant light traces the air. A smart table lamp, Loop is perfectly symmetrical and sleek, soothing and suave: a smooth luminaire.

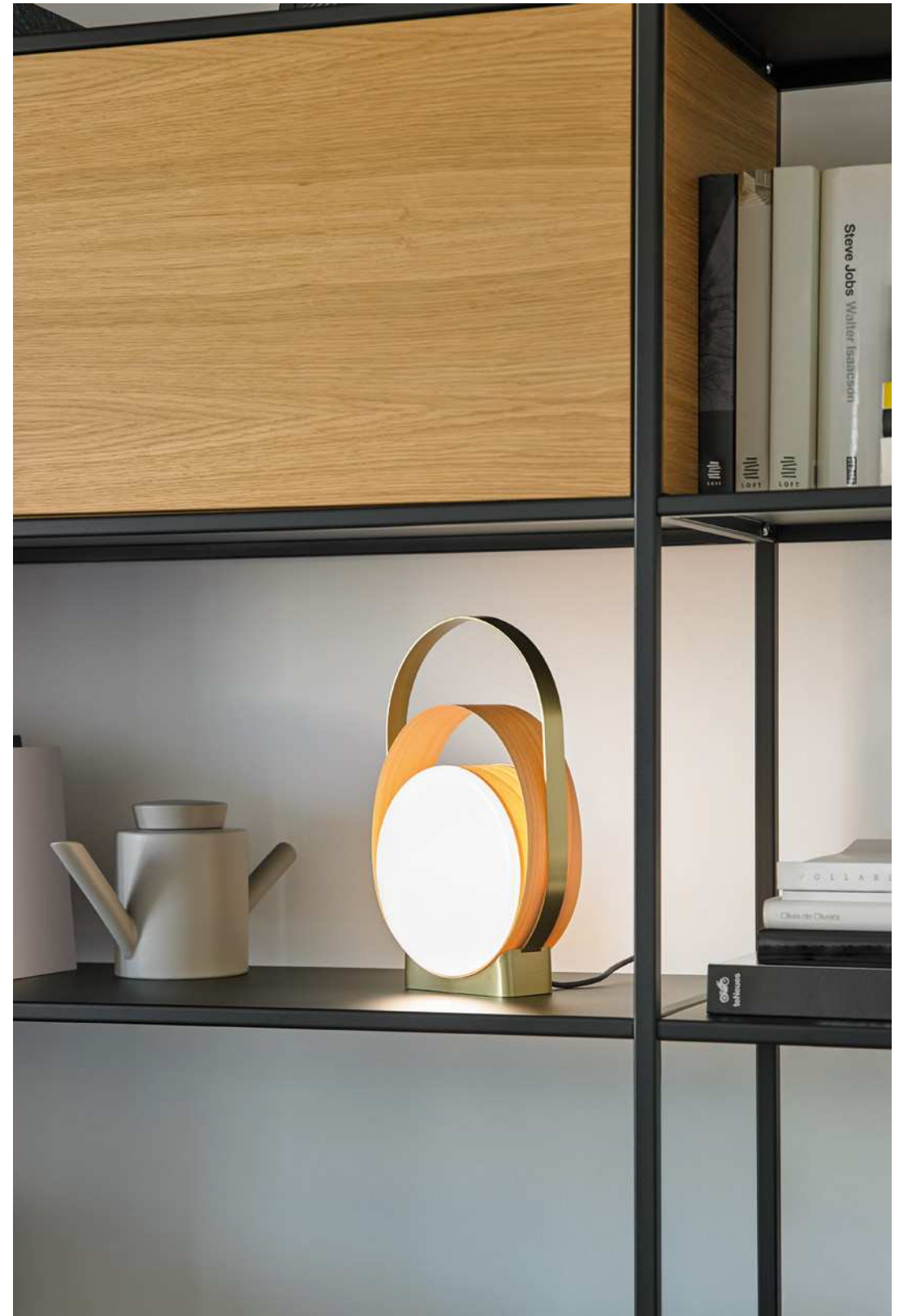



• **LOOP**
21 Natural Cherry Wood Veneer & Matt Black Metal Structure.

LOOP

TABLE

MUT DESIGN

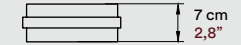
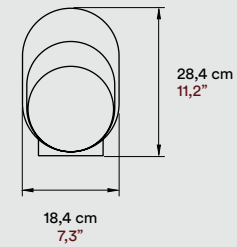

MATERIALS & COMPONENTS

Wood Veneer Strips

Metal Handle & Base

Acrylic Diffuser

Electrical Cable with Dimming Switch
145 cm 57"

LIGHT SOURCE

230V
LED Integrated Dimmable



Class II  

120V
LED Integrated Dimmable



FINISHES

WOOD VENEER

 21 Natural Cherry  22 Natural Beech

METAL

 Matt Black  *Black Nickel
 *Gold

*On Request

LO

Designed by:
Ray Power



Lola

Suspension
Floor
Table

Lola is the latest lamp for LZF designed by long-time collaborator Ray Power. Showcasing Power's ability to create imaginative three-dimensional forms, Lola is a conical lamp with an intricate geometric pattern. A veritable labour of love, Lola's shape went through many iterations, drawings and prototypes. The end result is, without doubt, a marvel of lighting design.

A particularly piquant Spanish name, Lola is very much alive, sensuous and intriguing. In a domestic or contract setting, Lola is a lamp that attracts and pleases the eye. Highly original and truly sophisticated, Lola's complex veneer construction is both accentuated and softened when illuminated. Available in a number of sizes and LZF's range of natural wood colours, Lola is stimulating, fascinating, arresting and sparkling: an especially piquant light.

• **LOLA MEDIUM SUSPENSION**

22 Natural Beech Wood Veneer. "Bouet" Restaurant.
Valencia, Spain. Architect: Ramón Esteve Estudio.



- **LOLA - SUSPENSION**
22 Natural Beech Wood Veneer.



LOLA

SUSPENSION

RAY POWER

MEDIUM

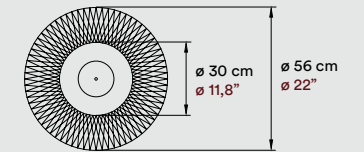
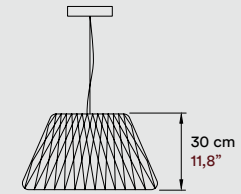

LARGE

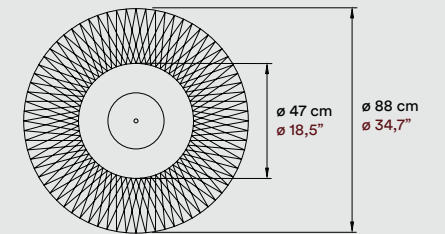
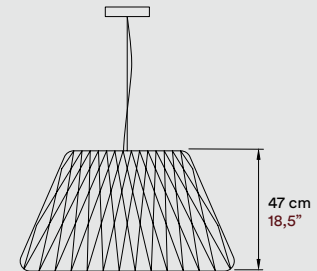

MATERIALS & COMPONENTS

Woven Wood Veneer Shade

Acrylic Frame

Metal Canopy

Steel Cable
2 m drop 8 ft drop

Electrical Cable
2 m drop 8 ft drop

FINISHES

WOOD VENEER

- 20 Ivory White
- 29 Grey
- 22 Natural Beech

METAL CANOPY

- Matt Black
- *Matt White
- *Brushed Nickel

*On Request

LIGHT SOURCE

120 - 277V
LED Integrated
Dimmable 0-10V, Bluetooth or DALI

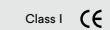

120 - 277V
LED Integrated
Dimmable 0-10V & TRIAC





● **LOLA - FLOOR**
 20 Ivory White Wood Veneer & Black Nickel Metal Foot.
 "Casa en la Huerta". Valencia, Spain. Architect: Ramón Esteve Estudio.

LOLA

FLOOR

RAY POWER

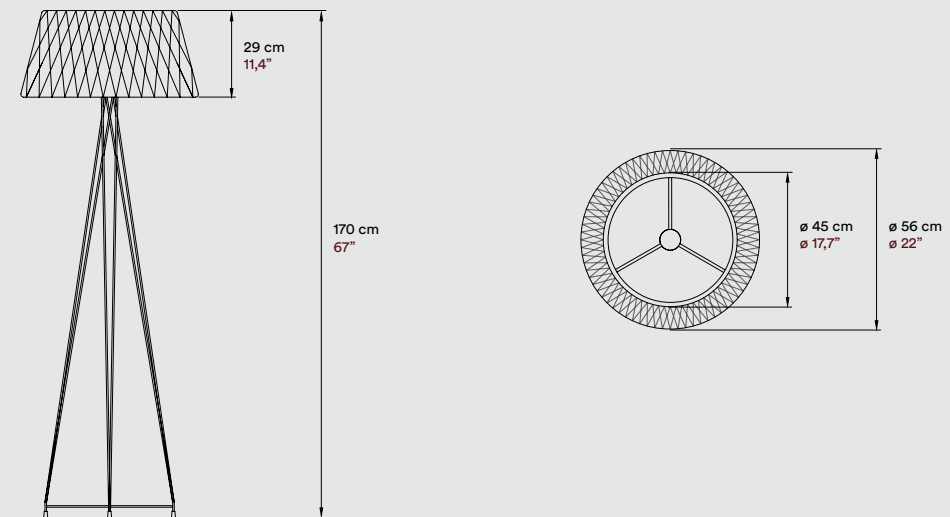

MATERIALS & COMPONENTS

Woven Wood Veneer Shade

Acrylic Frame

Metal Foot

Electrical Cable with Dimming Switch
 185 cm 53"

LIGHT SOURCE

220 - 250V
 Bulb E27

Class II

120V
 Bulb E26

FINISHES

WOOD VENEER

- 20 Ivory White
- 29 Grey
- 22 Natural Beech

METAL

- Matt Ivory
- *Black Nickel
- Matt Black
- *Gold

*On Request

- LOLA - TABLE MEDIUM**
 20 Ivory White Wood Veneer & Black Nickel Metal
 Foot. "Bouet" Restaurant. Valencia, Spain.
 Architect: Ramón Esteve Estudio.



- LOLA - TABLE MEDIUM**
 20 Ivory White Wood Veneer &
 Ivory White, Matt Black & Gold Metal.



LOLA

TABLE

RAY POWER

SMALL

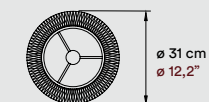
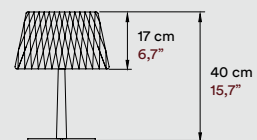

MEDIUM

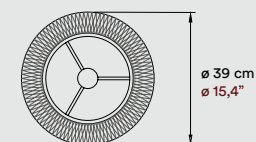
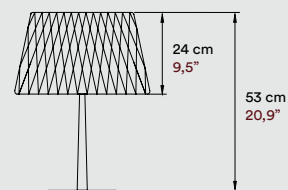

LARGE LUX

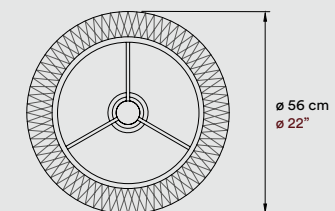
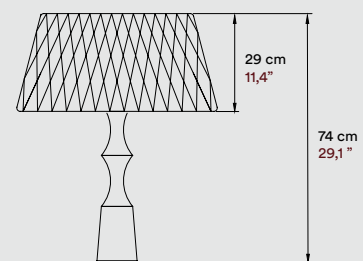

MATERIALS & COMPONENTS

Woven Wood Veneer Shade

Acrylic Frame

Metal or Marble Foot

Electrical Cable with Dimming Switch

145 cm 57"

LIGHT SOURCE

220 - 250V
Bulb E27

Class II

120V
Bulb E26

FINISHES

WOOD VENEER

20 Ivory White 29 Grey

22 Natural Beech

METAL

Matt Ivory *Black Nickel

Matt Black *Gold

*On Request

MARBLE LOLA LARGE LUX

Black "Marquina" Marble



• LOLA LUX | 20 Ivory White Wood Veneer & Black Marble Base. "Cosin" Workspace. Valencia, Spain.

THE
COLLEC
TION

A

G A

Agatha

Designed by:
Luis Eslava Studio

Ball
Small
Large

With an arresting and dramatic demeanour, Agatha fills the room with her ambient glow and appealing body. Agatha's elegant interlacing whorls of handmade wood veneer strips spring concentrically from its centre, their mass blossoming and flourishing.

T

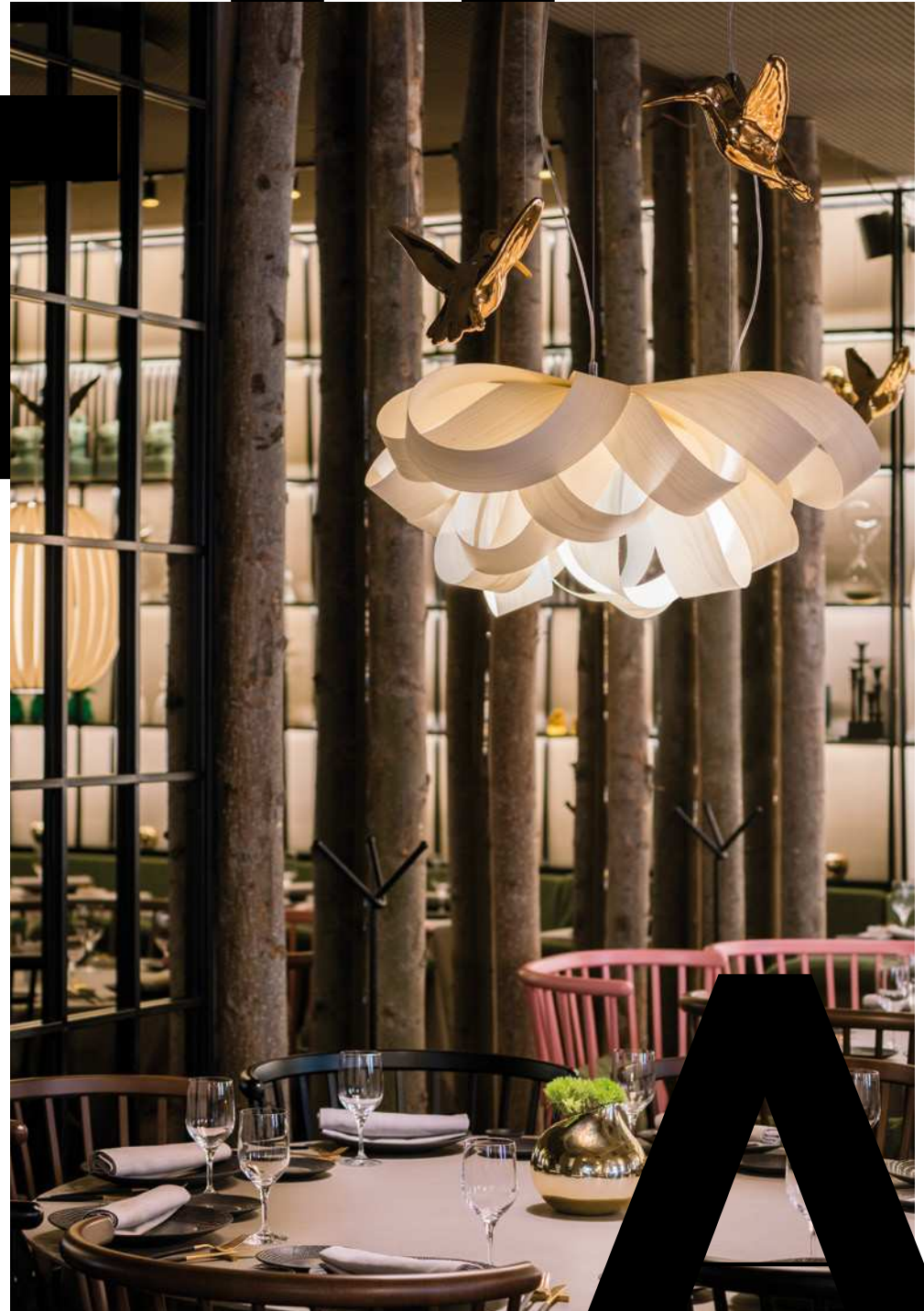

● **AGATHA - SMALL SUSPENSION**
20 Ivory White Wood Veneer. "Alameda" Restaurant. Madrid, Spain.
Architect: José Castro. Interior Designer: Evangelía Chalastsakos.



● **AGATHA - BALL SUSPENSION**
20 Ivory White Wood Veneer.
"Ma Khin" Cafe. Valencia, Spain.



● **AGATHA - LARGE SUSPENSION**
20 Ivory White Wood Veneer.
"Villa El Nido". Architects: A-cero. Marbella, Spain.

AGATHA

SUSPENSION

LUIS ESLAVA STUDIO

BALL



MATERIALS & COMPONENTS

Wood Veneer Shade

Metal Canopy

Steel Cable
2 m drop 8 ft drop

Electrical Cable
2 m drop 8 ft drop

FINISHES

WOOD VENEER

- 20 Ivory White
- 25 Orange
- 22 Natural Beech
- 33 Pale Rose
- 24 Yellow

LIGHT SOURCE

120 - 277V
LED Integrated
Dimmable 0-10V, Bluetooth or DALI
or
220 - 250V
6 Bulbs E27

Class I

120 - 277V
LED Integrated
Dimmable 0-10V & TRIAC
or
120 - 277V
6 Bulbs E26 or GU24

AWARDS

HD Las Vegas. Product Design Competition. USA
WAN LIGHTING. World Architecture Award. USA

SMALL

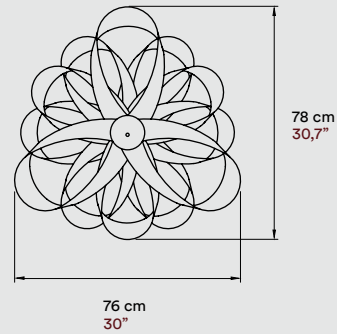
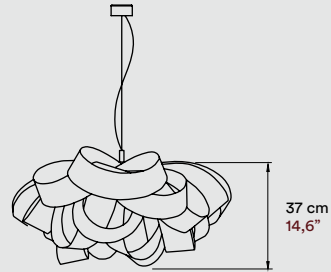

MATERIALS & COMPONENTS

Wood Veneer Shade

Metal Canopy

Steel Cable

2 m drop 8 ft drop

Electrical Cable

2 m drop 8 ft drop

LIGHT SOURCE

120 - 277V

LED Integrated
Dimmable 0-10V, Bluetooth or DALI
or

220 - 250V

Bulb E27

Class I

120 - 277V

LED Integrated
Dimmable 0-10V & TRIAC
or

120 - 277V

Bulb E26 or GU24



FINISHES

WOOD VENEER



LARGE

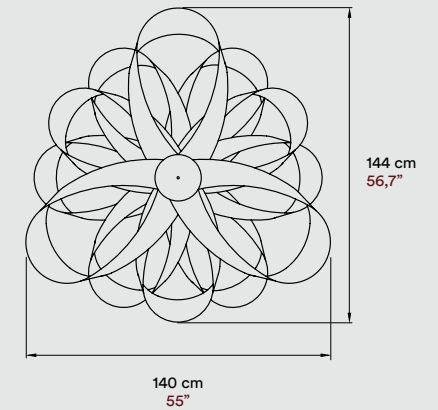
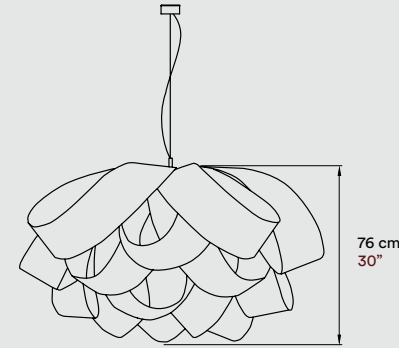

MATERIALS & COMPONENTS

Wood Veneer Shade

Metal Canopy

Steel Cable

2 m drop 8 ft drop

Electrical Cable

2 m drop 8 ft drop

LIGHT SOURCE

120 - 277V

LED Integrated
Dimmable 0-10V, Bluetooth or DALI
or

220 - 250V

3 Bulbs E27

Class I

120 - 277V

LED Integrated
Dimmable 0-10V & TRIAC
or

120 - 277V

3 Bulbs E26 or GU24



AIR



Air

Table
Wall

Designed by:
Ray Power

The Air light is sublime, graceful and enchanting. Its shape exhibits the designer's characteristic penchant for imaginative three-dimensional forms. The Air lamp's pleats and folds work to create a unique wood veneer light, one whose character demonstrates balance with equanimity and restraint.

Air lamp diffuses light in a manner that is flawless and low-key, its singular silhouette shining with a radiant warmth and vitality. A free-flowing, effortless light, Air lamp enjoys a distinctly individual profile.

• AIR - TABLE & WALL
20 Ivory White Wood Veneer.



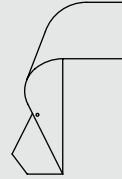
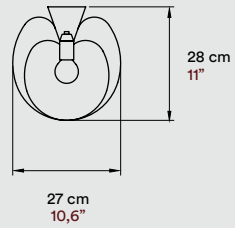
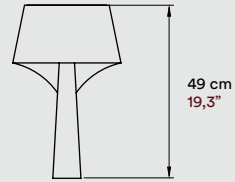

MATERIALS & COMPONENTS

Wood Veneer Shade

Metal Base

Electrical Cable with Dimming Switch
145 cm 57"

LIGHT SOURCE

220 - 250V Bulb E14 Class II 

120V Bulb E12 

FINISHES

WOOD VENEER

- | | |
|---|--|
|  20 Ivory White |  28 Blue |
|  21 Natural Cherry |  29 Grey |
|  22 Natural Beech |  30 Turquoise |
|  24 Yellow |  31 Chocolate |
|  25 Orange |  33 Pale Rose |
|  26 Red | |

AWARDS



Chicago

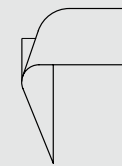
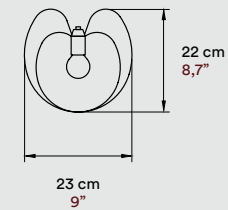
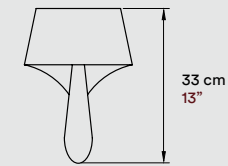



MATERIALS & COMPONENTS

Wood Veneer Shade

Metal Back Plate

LIGHT SOURCE

220 - 250V Bulb E14 Class I 

120V Bulb E12 

FINISHES

WOOD VENEER

- | | |
|---|--|
|  20 Ivory White |  28 Blue |
|  21 Natural Cherry |  29 Grey |
|  22 Natural Beech |  30 Turquoise |
|  24 Yellow |  31 Chocolate |
|  25 Orange |  33 Pale Rose |
|  26 Red | |

BANGA

Banga

Designed by:
Yonoh Creative Studio

Medium
Large

The Banga light's combined veneer pieces and metal frame bear a resemblance to a plush brolly or indeed, to a well dressed parasol. Banga enjoys an expressive Eastern world-like quality, together with a nod to neoclassicism and its principles of simplicity and symmetry.

- **BANGA - LARGE SUSPENSION**
26 Red Wood Veneer. "Le Meridien" Hotel. Tarragona, Spain.

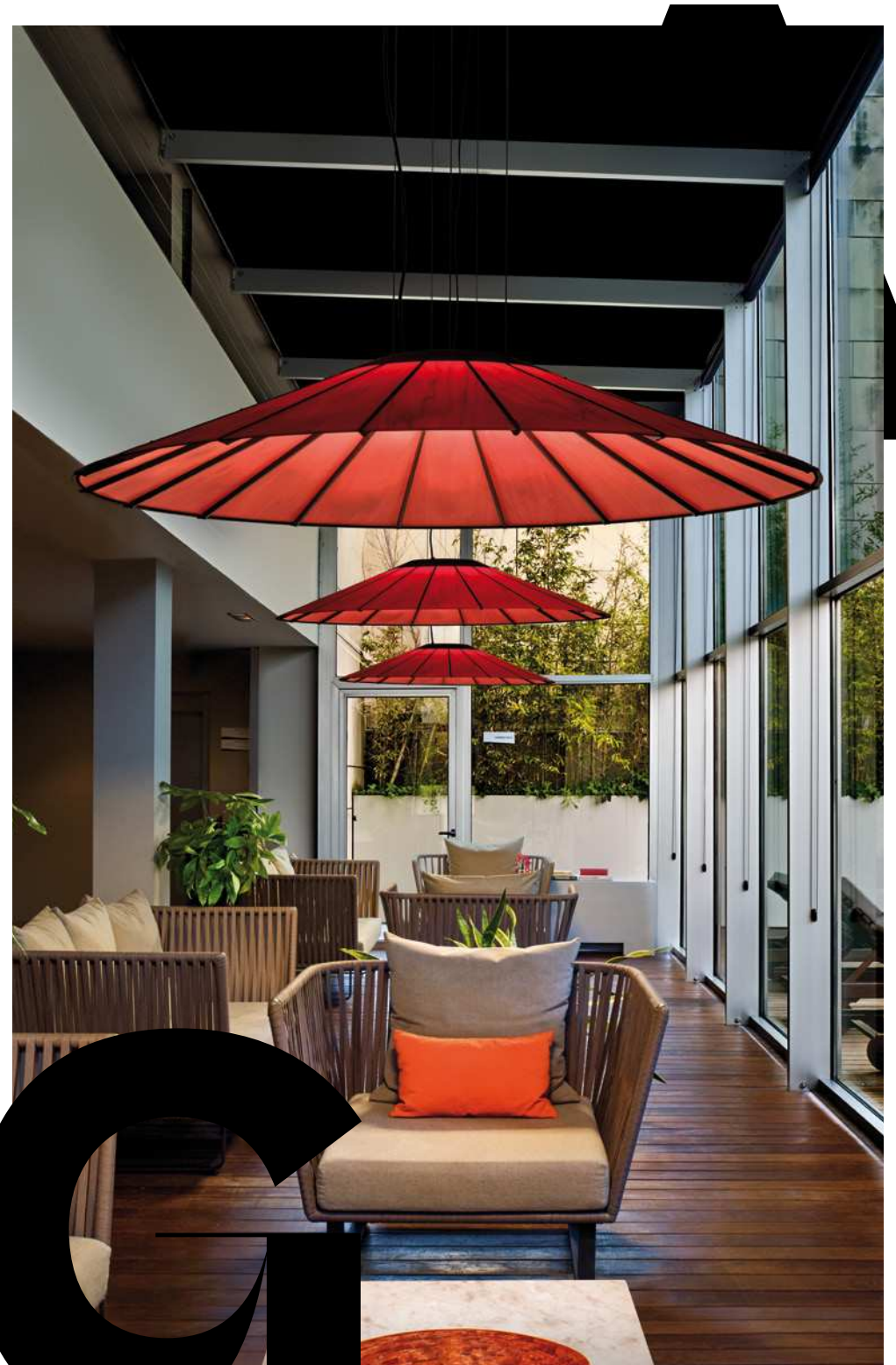

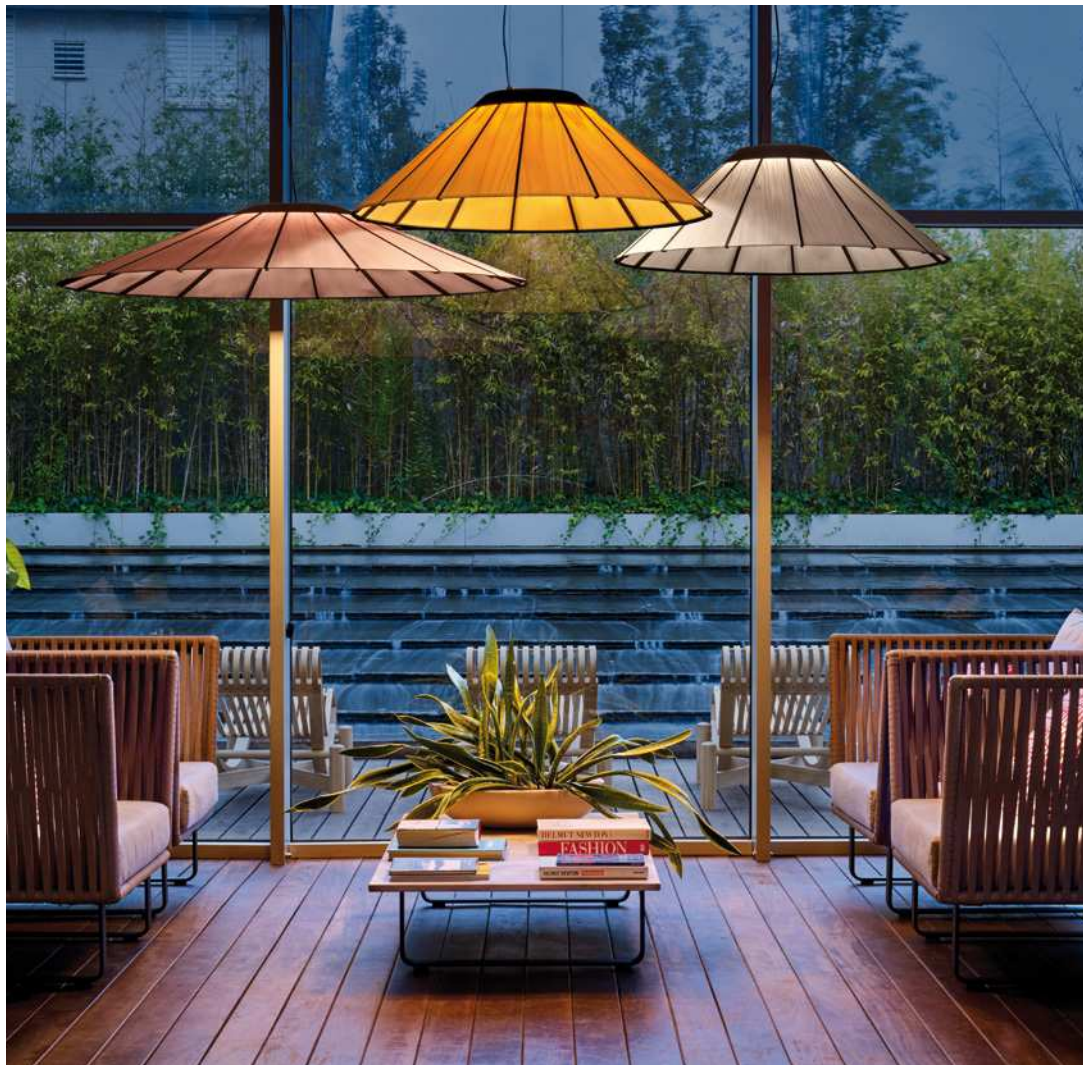

• **BANGA - LARGE & MEDIUM SUSPENSION**
 33 Pale Rose, 24 Yellow & 29 Grey Wood Veneer.
 "Le Meridien" Hotel. Tarragona, Spain.

BANGA

SUSPENSION

YONOH CREATIVE STUDIO

MEDIUM

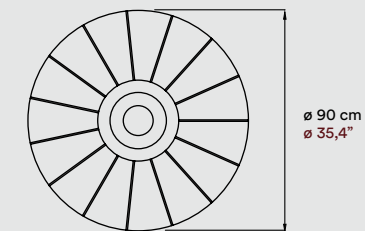
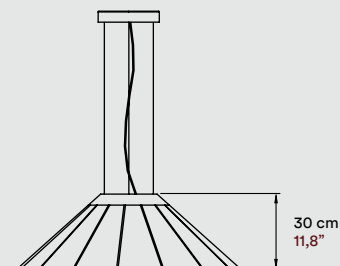

LARGE

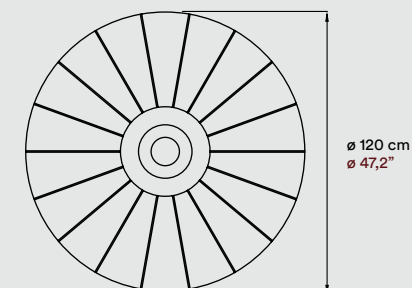
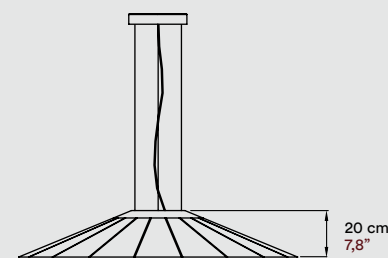

MATERIALS & COMPONENTS

Wood Veneer Shade

Acrylic Diffuser

Metal Structure & Canopy

3 Steel Cables
 2 m drop 8 ft drop

Electrical Cable
 2 m drop 8 ft drop

LIGHT SOURCE

120 - 277V
 LED Integrated
 Dimmable 0-10V, Bluetooth or DALI

Class I CE

120 - 277V
 LED Integrated
 Dimmable 0-10V & TRIAC

cULus

FINISHES

WOOD VENEER

- 20 Ivory White
- 21 Natural Cherry
- 22 Natural Beech
- 24 Yellow
- 25 Orange
- 26 Red
- 28 Blue
- 29 Grey
- 30 Turquoise
- 31 Chocolate
- 33 Pale Rose

AWARDS



Chicago



Germany

CAVI DE LABRO

Candelabro

Small
Large

Designed by:
Mariví Calvo

Imagine a suspension light that embodies many of LZF's greatest hits. Candelabro describes a remarkably representational form that unites the finest collection of wood veneer pendants. The performers include such luminaries as Agatha and Mikado, Raindrop and Totem. Hovering amid the lights are a number of golden birds, each one enjoying a magical world of wonder. Together, these birds and the various pendants stage a thrilling opus in light, a majestic piece that will give the viewer pleasure every time.

• CANDELABRO - SMALL SUSPENSION
20 Ivory White Wood Veneer. "Alameda" Restaurant. Madrid, Spain.





• **CANDELABRO**
LARGE SUSPENSION
 20 Ivory White Wood Veneer.
 LZF Showroom. Chiva, Valencia.



CANDELABRO

SUSPENSION

MARIVÍ CALVO

SMALL

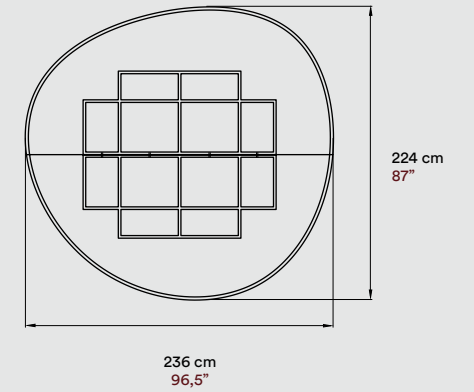
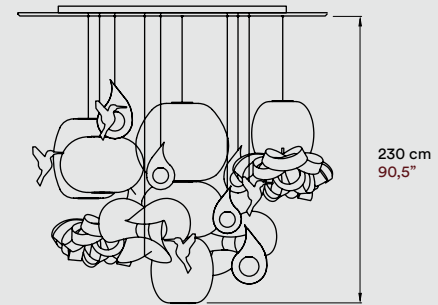

LARGE

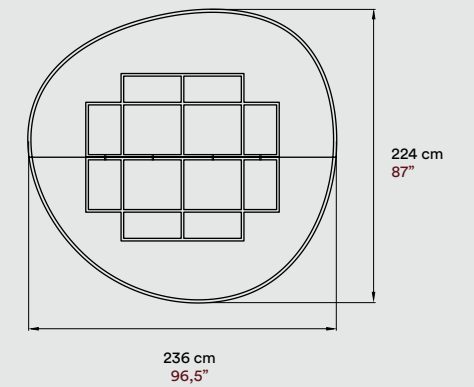
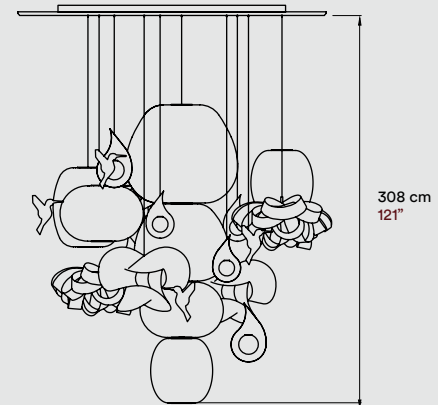

MATERIALS & COMPONENTS

15 Wood Veneer Shades

Lacquered Wood Canopy

Ceramic Birds in Gold or White Glaze

LIGHT SOURCE

3 Independent Dimmable Circuits.
 Dimming & Control of the Central Shade,
 Periferal Shades & Soptlights.

220 - 250V

Class I

FINISHES

120V

WOOD VENEER

20 Ivory White

22 Natural Beech

Carambola

Small
Medium



Designed by:
Oskar Cerezo

This lamp takes its title and distinguishing shape from the fruit Carambola. This starfruit is typically native to countries in the East and rather appropriately, this light assumes a somewhat Orient-like quality.

**A
M
C
I
R
A
O
L
A**



● **CARAMBOLA - MEDIUM & SMALL SUSPENSION**
 21 Natural Cherry Wood Veneer.
 "Caro" Hotel. Valencia, Spain.

CARAMBOLA

SUSPENSION

OSKAR CEREZO

SMALL

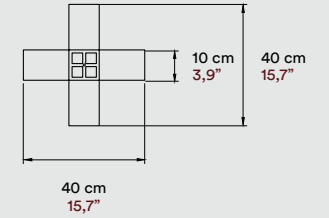
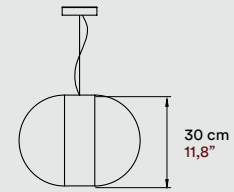

MEDIUM

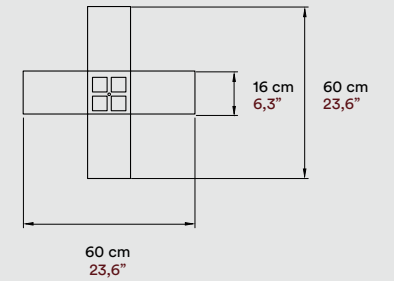
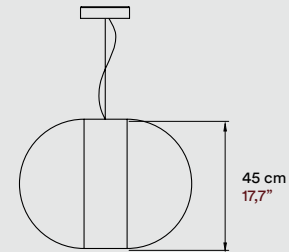

MATERIALS & COMPONENTS

Wood Veneer Shade

Acrylic Diffuser

Metal Trims & Canopy

Steel Cable
 2 m drop 8 ft drop

Electrical Cable
 2 m drop 8 ft drop

FINISHES

WOOD VENEER

- 20 Ivory White
- 21 Natural Cherry
- 22 Natural Beech
- 24 Yellow
- 25 Orange
- 26 Red
- 28 Blue
- 29 Grey
- 30 Turquoise
- 31 Chocolate
- 33 Pale Rose

LIGHT SOURCE

120 - 277V
 LED Integrated
 Dimmable 0-10V, Bluetooth or DALI

Class I

120 - 277V
 LED Integrated
 Dimmable 0-10V & TRIAC

CERVANTES

Cervantes

Suspension
Ceiling

Designed by:
Burkhard Dämmer

Cervantes is a truly noble light, its shapely form both splendid and sublime. When creating this lamp, designer was inspired by Señor Miguel de Cervantes, a Spanish novelist and dramatist who was fond of sporting a ruff collar.

Cervantes demonstrates the remarkable pliability of wood veneer. The ruff-like pattern, with its elaborate figure-of-eight folds, is fashioned into an intriguing latticework of wood strips. Set into a luminaire shaped like a concave lens, the wood strips make the ideal light diffuser.

With an air of the Renaissance and a touch of the Baroque, Cervantes is a hi-tech light hailing from noble roots.

• **CERVANTES - SUSPENSION**

Matt Black Metal Shell & 21 Natural Cherry Wood Veneer.
"Ma Khin" Cafe. Valencia, Spain.





• **CERVANTES
SUSPENSION**
21 Natural Cherry
Wood Veneer & Matt
Black Metal Shell.

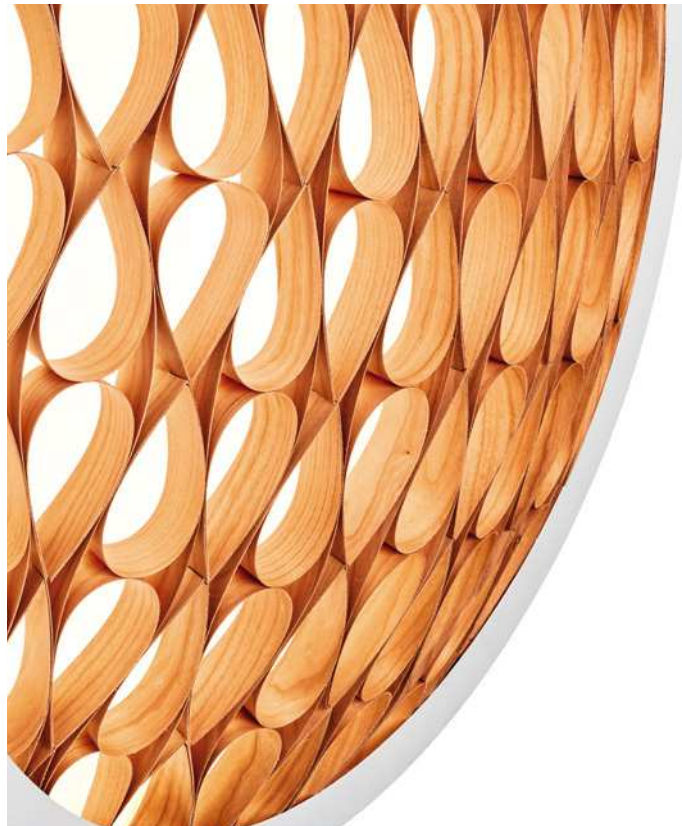

• **CERVANTES**
21 Natural Cherry
Wood Veneer & Matt
White Metal Shell.

CERVANTES

SUSPENSION

BURKHARD DÄMMER

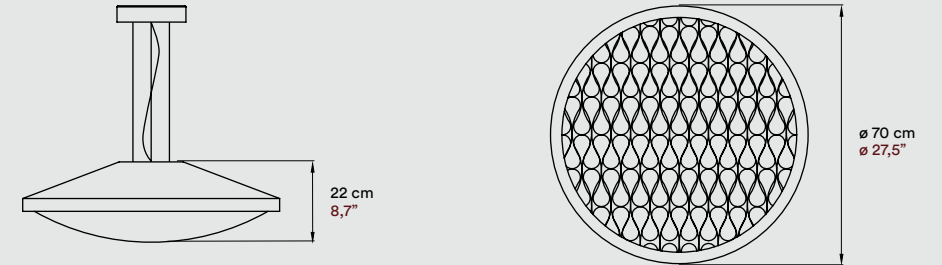

MATERIALS & COMPONENTS

Woven Wood Veneer Shade

Acrylic Diffuser

Metal Shell & Canopy

3 Steel Cables
2 m drop 8 ft drop

Electrical Cable
2 m drop 8 ft drop

LIGHT SOURCE

120 - 277V
LED Integrated
Dimmable 0-10V, Bluetooth or DALI

Class I

120 - 277V
LED Integrated
Dimmable 0-10V & TRIAC

FINISHES

WOOD VENEER

- 20 Ivory White
- 21 Natural Cherry
- 22 Natural Beech
- 24 Yellow
- 25 Orange
- 26 Red
- 28 Blue
- 29 Grey
- 30 Turquoise
- 31 Chocolate
- 33 Pale Rose

METAL

- Matt White
- Matt Black



● **CERVANTES - CEILING**
 20 Ivory White Wood Veneer & Matt Black Metal Shell.
 "Villa El Nido". Architects: A-cero. Marbella, Spain.

CERVANTES

CEILING

BURKHARD DÄMMER

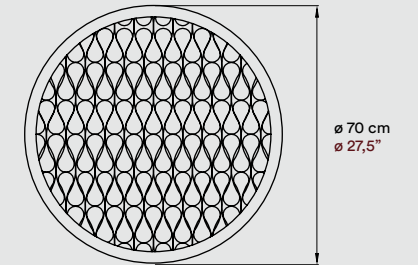
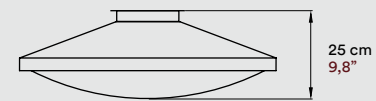

MATERIALS & COMPONENTS

Woven Wood Veneer Shade

Acrylic Diffuser

Metal Shell

LIGHT SOURCE

120 - 277V
 LED Integrated
 Dimmable 0-10V, Bluetooth or DALI

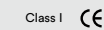

120 - 277V
 LED Integrated
 Dimmable 0-10V & TRIAC



FINISHES

WOOD VENEER

- | | |
|---------------------|----------------|
| ● 20 Ivory White | ● 28 Blue |
| ● 21 Natural Cherry | ● 29 Grey |
| ● 22 Natural Beech | ● 30 Turquoise |
| ● 24 Yellow | ● 31 Chocolate |
| ● 25 Orange | ● 33 Pale Rose |
| ● 26 Red | |

METAL

- | | |
|--------------|--------------|
| ● Matt White | ● Matt Black |
|--------------|--------------|

MINI CHOU



Mini Chou

Designed by:
Yonoh Creative Studio

The simplicity and charm of the Mini Chou, inspired by the traditional Japanese lantern called chou-chin, is able to capture the enchantment of the moment through light.

Mini Chou is the perfect companion for modern life: wireless, handy and exceptionally versatile. Handmade in natural wood veneer in Spain, Mini Chou has a dimmer that allows you to create the level of intimacy required.

With a whole world to discover, just how far will your Mini Chou take you?

• **MINI CHOU - CORDLESS**
20 Ivory White, 22 Beech, 29 Grey & 33 Pale Rose Wood Veneer.
"Bouet" Restaurant. Valencia, Spain. Architect: Ramón Esteve Estudio.



● **MINI CHOU - CORDLESS**
22 Natural Beech Wood Veneer.

CHOU

CORDLESS TABLE

YONOH CREATIVE STUDIO

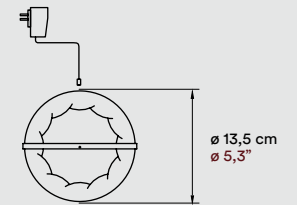
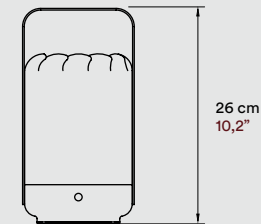

MATERIALS & COMPONENTS

Wood Veneer Shade

Acrylic Diffuser

Metal Base & Handle

Rechargeable Battery
7 Hours Autonomy at 100% Power

IN Charge
USB type C

FINISHES

WOOD VENEER

- 20 Ivory White ● 29 Grey
- 22 Natural Beech ● 33 Pale Rose
- 26 Red ● 34 Sea Blue
- *On Request: 24 Yellow

LIGHT SOURCE

LED Integrated Dimmable

Class III ⚡ CE

LED Integrated Dimmable

C

H

O

U



- **CHOU - TALL TABLE**
21 Natural Cherry Wood Veneer.
"Palau de Casavells". Girona, Spain.

Chou

Table
Suspension

Designed by:
Yonoh Creative Studio

Designed by Yonoh Creative Studio, the Chou lamp is available in four table and four pendant versions. This deceptively simple light is especially pleasing when presented in a cluster of differing sizes. The Chou lamp catches the eye with its carefully considered pose.



● **CHOU - SHORT & TALL TABLE**
 30 Turquoise & 24 Yellow Wood Veneer.
 "Villa El Nido". Marbella, Spain. Architects: A-cero.

CHOU

TABLE

YONOH CREATIVE STUDIO

SHORT

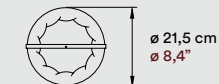
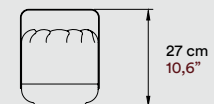

TALL

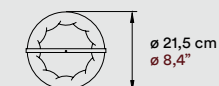
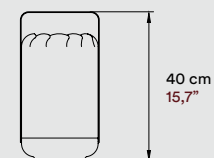

MATERIALS & COMPONENTS

Wood Veneer Shade

Metal Base & Handle

Electrical Cable with Dimming Switch
 130 cm 49"

LIGHT SOURCE

220 - 250V
 Bulb E27

Class II

120V
 Bulb E26

FINISHES

WOOD VENEER

- | | |
|-------------------|--------------|
| 20 Ivory White | 26 Red |
| 21 Natural Cherry | 28 Blue |
| 22 Natural Beech | 29 Grey |
| 24 Yellow | 30 Turquoise |
| 25 Orange | 33 Pale Rose |

AWARDS



Germany



• **CHOU - TALL & SHORT SUSPENSION**
 20 Ivory White Wood Veneer.
 "El Tilo de Sorní". Valencia, Spain.
 Interior Design: Cosin Estudio.

CHOU

SUSPENSION

YONOH CREATIVE STUDIO

SHORT

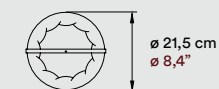
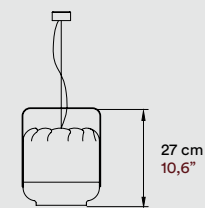

TALL

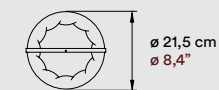
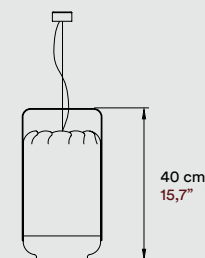

MATERIALS & COMPONENTS

Wood Veneer Shade

Acrylic Bottom Diffuser

Metal Base, Handle & Canopy

Steel Cable
 2 m drop 8 ft drop

Electrical Cable
 2 m drop 8 ft drop

FINISHES

WOOD VENEER

- | | |
|---------------------|----------------|
| ● 20 Ivory White | ● 26 Red |
| ● 21 Natural Cherry | ● 28 Blue |
| ● 22 Natural Beech | ● 29 Grey |
| ● 24 Yellow | ● 30 Turquoise |
| ● 25 Orange | ● 33 Pale Rose |

LIGHT SOURCE

220 - 250V
 Bulb E27

Class I CE

120 - 277V
 Bulb E26 or GU24

cULUS

AWARDS



Germany

C

U



A

Cuad

Designed by:
Burkhard Dämmer

- **CUAD - MEDIUM SUSPENSION**
21 Natural Cherry Wood Veneer. "Villa El Nido". Marbella, Spain.

The Cuad light is an architecturally pertinent pendant and one that illuminates a space with equanimity. The Cuad's wood veneer cuboid shape recalls the spirit of midcentury modern style with an understated elegance. Yet beneath that calm exterior, powerful electronic technology works with tremendous fervour to ensure that Cuad delivers its versatile light across a range of interior environments.

D

- **CUAD - SUSPENSION**
30 Turquoise Wood Veneer.
"Ma Khin" Cafe. Valencia, Spain.



CUAD

SUSPENSION

BURKHARD DÄMMER

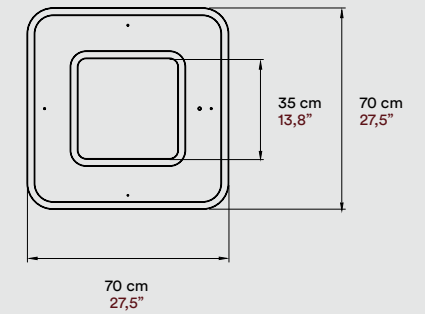
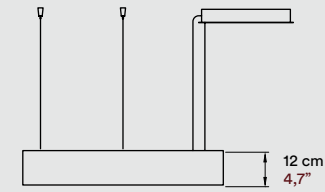

MATERIALS & COMPONENTS

Wood Veneer Shade

Top & Bottom Acrylic Diffuser

Metal Canopy

Electrical Cable
2 m drop 8 ft drop

4 Steel Cables
2 m drop 8 ft drop

LIGHT SOURCE

120 - 277V
LED Integrated
Dimmable 0-10V, Bluetooth or DALI

Class I

120 - 277V
LED Integrated
Dimmable 0-10V & TRIAC

FINISHES

WOOD VENEER

- | | |
|-------------------|--------------|
| 20 Ivory White | 28 Blue |
| 21 Natural Cherry | 29 Grey |
| 22 Natural Beech | 30 Turquoise |
| 24 Yellow | 31 Chocolate |
| 25 Orange | 33 Pale Rose |
| 26 Red | |

D

A

N

D

Dandelion

Designed by:
Burkhard Dämmer

Bearing a resemblance to its flowering namesake, this lamp is a radiant composite of many single florets. Independent and distinct, each funnel-shaped floret appears to shine alone, yet en masse they create the Dandelion's sparkle.

E



• DANDELION - SUSPENSION
26 Red Wood Veneer.

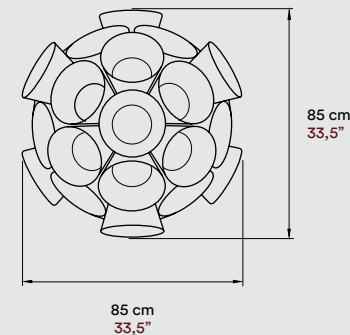
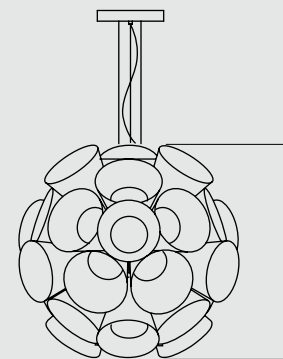

MATERIALS & COMPONENTS

Wood Veneer Shade

Acrylic Diffusers

Metal Canopy

3 Steel Cables
2 m drop 8 ft drop

Electrical Cable
2 m drop 8 ft drop

LIGHT SOURCE

120 - 277V
LED Integrated
Dimmable 0-10V, Bluetooth or DALI

Class I CE

120 - 277V
LED Integrated
Dimmable 0-10V



FINISHES

WOOD VENEER

- 20 Ivory White
- 21 Natural Cherry
- 22 Natural Beech
- 24 Yellow
- 25 Orange
- 26 Red
- 28 Blue
- 29 Grey
- 30 Turquoise
- 31 Chocolate
- 33 Pale Rose

AWARDS



Chicago



Germany



Brussels

• DANDELION - SUSPENSION
24 Yellow Wood Veneer.

Domo

Designed by:
Rqr Studio



With its handsome form, Domo is reserved, strong and aesthetically presented. This lamp consists of two layers: an outer layer formed using four interlocking timber veneer slats and an inner layer fashioned from seamless veneer joints. In history, the dome is a structure that exhibits strength. It is therefore fitting that Domo is an earnest light, with an inner flame and passion that truly shines.

Domo reflects light downwards and is perfect for a variety of tasks and chores. Pure, simple and practical, Domo is delightfully earnest.

• **DOMO - SUSPENSION** | 21 Natural Cherry Wood Veneer.





• **DOMO - SUSPENSION**
24 Yellow Wood Veneer.

DOMO

SUSPENSION

RQR ESTUDIO

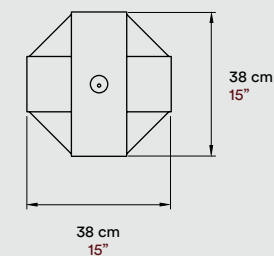
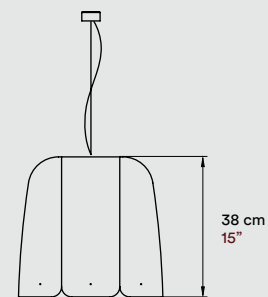

MATERIALS & COMPONENTS

Wood Veneer Shade

Metal Canopy

Steel Cable
2 m drop 8 ft drop

Electrical Cable
2 m drop 8 ft drop

LIGHT SOURCE

220 - 250V
Bulb E27

Class I

120 - 277V
Bulb E26 or GU24



FINISHES

WOOD VENEER

- | | |
|-------------------|--------------|
| 20 Ivory White | 26 Red |
| 21 Natural Cherry | 28 Blue |
| 22 Natural Beech | 29 Grey |
| 24 Yellow | 30 Turquoise |
| 25 Orange | 33 Pale Rose |



Escape

Designed by:
Ray Power

Small
Large

ESCAPE

Escape is an avant-garde pendant with a smart domino-like structure. Its self-supporting veneer panels give the impression of falling into a ring of light, their form defying gravity.

Designed by Ray Power, Escape is a truly handsome, self-assured light. While enjoying a little bit of swagger and appearing fairly pleased with itself, the Escape pendant's manner is bright and buoyant. Moreover, Escape is entirely affable, having an approachable quality that is perfect for any well turned out setting.

- **ESCAPE - SMALL SUSPENSION** |
20 Ivory White Wood Veneer. "Caro" Hotel. Valencia, Spain.

- **ESCAPE - SMALL & LARGE SUSPENSION**
33 Pale Rose Wood Veneer.
"La Monella" Jewellers.
Valencia, Spain.

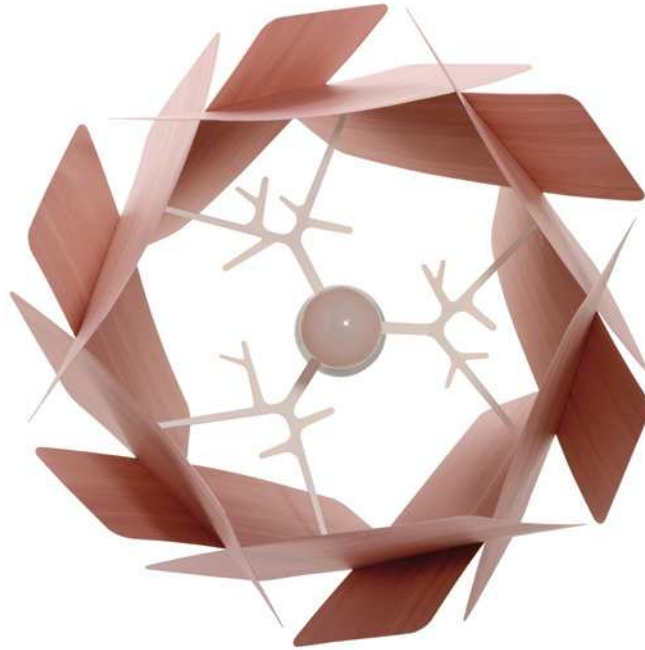

ESCAPE

SUSPENSION

RAY POWER

SMALL

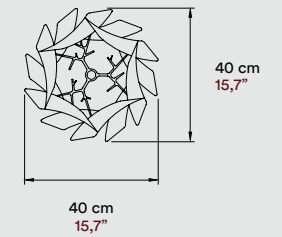
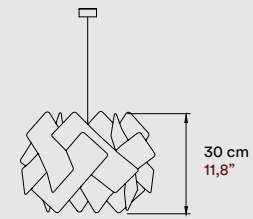

LARGE

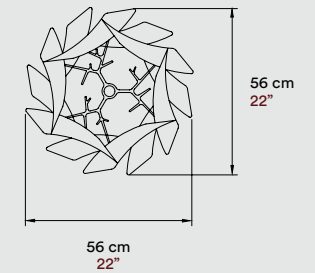
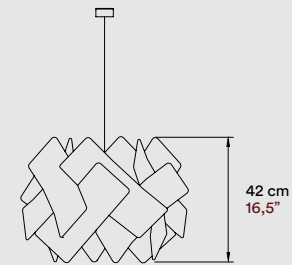

MATERIALS & COMPONENTS

Wood Veneer Shade

Metal Tripod & Canopy

Electrical Cable
2 m drop 8 ft drop

LIGHT SOURCE

220 - 250V
Bulb E27

Class I

120 - 277V
Bulb E26 or GU24

FINISHES

WOOD VENEER

- | | |
|-------------------|--------------|
| 20 Ivory White | 28 Blue |
| 21 Natural Cherry | 29 Grey |
| 22 Natural Beech | 30 Turquoise |
| 24 Yellow | 31 Chocolate |
| 25 Orange | 33 Pale Rose |
| 26 Red | |

AWARDS



Chicago

GEA COSMOS

Suspension
Floor
Ceiling
Wall

Designed by:
Mariví Calvo



• GEA - LARGE SUSPENSION | 29 Grey Wood Veneer. Photo: 4000k.

A versatile all-rounder, Gea is a solid and circular suspension, ceiling, wall and floor lamp (named 'Cosmos'). Gea's modest form is smart, self-possessed and clean-cut. A steadfast performer, Gea radiates warmth from its wood veneer sides, the resulting effect satisfyingly serene.

We find a light that is unpretentious and yet highly accomplished, its versatility knowing no bounds. From a series of Super Gea pendants hanging in the hallways of power to a Gea ceiling lamp fixed in a minimalist space, this appealing light is reassuringly loyal.



• GEA - LARGE SUSPENSION | 29 Grey Wood Veneer. "Le Meridien" Hotel. Tarragona, Spain. Photo: 4000k.

SMALL

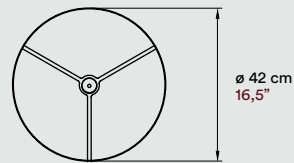
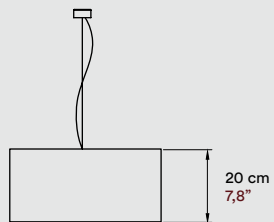

LARGE

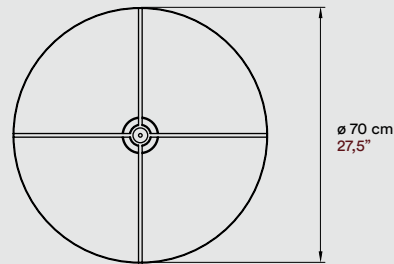
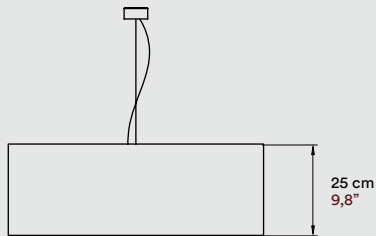

MATERIALS & COMPONENTS

Wood Veneer Shade

Acrylic Diffuser

Metal Tripod & Canopy

Steel Cable
2 m drop 8 ft drop

Electrical Cable
2 m drop 8 ft drop

LIGHT SOURCE

220 - 250V
SMALL Bulb E27
LARGE 3 Bulbs E27

Class I

120 - 277V
SMALL Bulb E26 or GU24
LARGE 3 Bulbs E26 or GU24



FINISHES

WOOD VENEER

- 20 Ivory White
- 21 Natural Cherry
- 22 Natural Beech
- 24 Yellow
- 25 Orange
- 26 Red
- 28 Blue
- 29 Grey
- 30 Turquoise
- 31 Chocolate
- 33 Pale Rose

SLIM

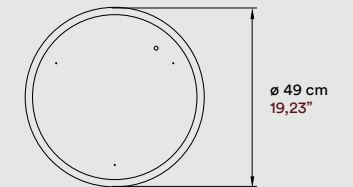
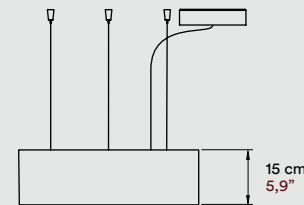

MATERIALS & COMPONENTS

Wood Veneer Shade

Top & Bottom Acrylic Diffuser

Metal Canopy

3 Steel Cables
2 m drop 8 ft drop

Electrical Cable
2 m drop 8 ft drop

LIGHT SOURCE

120 - 277V
LED Integrated
Dimmable 0-10V, Bluetooth or DALI

Class I

120 - 277V
LED Integrated
Dimmable 0-10V & TRIAC



FINISHES

WOOD VENEER

- 20 Ivory White
- 21 Natural Cherry
- 22 Natural Beech
- 24 Yellow
- 25 Orange
- 26 Red
- 28 Blue
- 29 Grey
- 30 Turquoise
- 31 Chocolate
- 33 Pale Rose



• **COSMOS - FLOOR** | 20 Ivory White.
 "Villa El Nido". Architects. A-cero. Marbella, Spain.

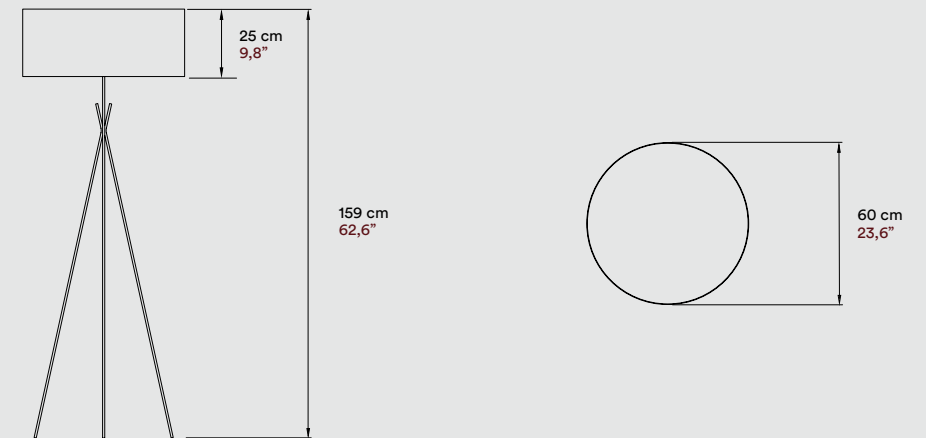

MATERIALS & COMPONENTS

Wood Veneer Shade

Acrylic Upper Diffuser

Metal Tripod & Base

Electrical Cable with Dimming Switch
 185 cm 53"

LIGHT SOURCE

220 - 250V
 3 Bulbs E27

Class II

120V
 3 Bulbs E26

FINISHES

WOOD VENEER

- | | |
|-------------------|--------------|
| 20 Ivory White | 28 Blue |
| 21 Natural Cherry | 29 Grey |
| 22 Natural Beech | 30 Turquoise |
| 24 Yellow | 31 Chocolate |
| 25 Orange | 33 Pale Rose |
| 26 Red | |



● **GEA LARGE CEILING**
29 Grey Wood Veneer.
Photo: 4000k.
"Le Meridien" Hotel.
Tarragona, Spain.



● **GEA - SMALL, MEDIUM & LARGE WALL**
29 Grey Wood Veneer.
Photo: 4000k.
"Le Meridien" Hotel.
Tarragona, Spain.

GEA

WALL & CEILING

MARIVÍ CALVO

SMALL

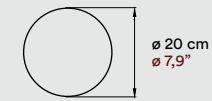

MEDIUM

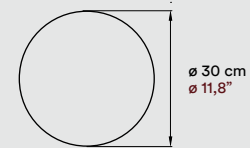

LARGE

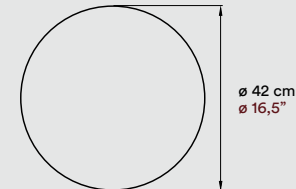

MATERIALS & COMPONENTS

Wood Veneer Shade

Acrylic Frontal Diffuser

Metal Back plate

LIGHT SOURCE

120 - 277V
LED Integrated
Dimmable 0-10V
or
220 - 250V
Bulb GX53

Class I CE

120 - 277V
LED Integrated
Dimmable 0-10V & TRIAC
or
120V
Bulb GX53



ADA Compliant

FINISHES

WOOD VENEER

- | | |
|---------------------|----------------|
| ● 20 Ivory White | ● 28 Blue |
| ● 21 Natural Cherry | ● 29 Grey |
| ● 22 Natural Beech | ● 30 Turquoise |
| ● 24 Yellow | ● 31 Chocolate |
| ● 25 Orange | ● 33 Pale Rose |
| ● 26 Red | |

Guijarro

Designed by:
Mariví Calvo

G

U

I

J

A

R



R

Guijarro is a family of three pebble-like lights, each one perfect for use on a wall or ceiling. This lamps were inspired by fine shingle: small, smooth and rounded pebbles whose individual shapes have been carved over many years by water and sand. A tiny wonder of nature, every pebble exhibits its own colour, contours and form.

With three different sizes and a choice of wood veneer finishes, the Guijarro lights are especially eye-catching when displayed in a group formation. Just as pebbles live in harmony, present a strong sense of oneness.

- GUIJARRO - SMALL, MEDIUM & LARGE
21 Natural Cherry, 24 Red & 29 Grey Wood Veneer.

O

- **GUIJARRO - SMALL, MEDIUM & LARGE WALL**
24 Yellow, 28 Blue, 26 Red & 25 Orange Wood Veneer.



GUIJARRO

WALL & CEILING

MARIVÍ CALVO

SMALL

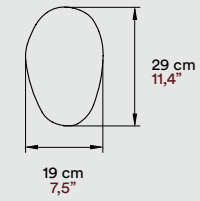

MEDIUM

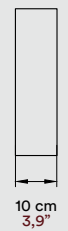
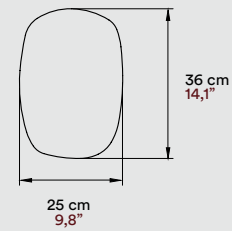

LARGE

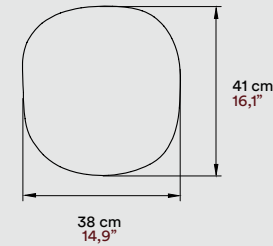

MATERIALS & COMPONENTS

Wood Veneer Shade

Acrylic Frontal Diffuser

Metal Back Plate

LIGHT SOURCE

120 - 277V
LED Integrated
Dimmable 0-10V
or

220 - 250V
Bulb GX53

Class I

120 - 277V
LED Integrated
Dimmable 0-10V & TRIAC
or

120V
Bulb GX53

ADA Compliant

FINISHES

WOOD VENEER

- | | |
|-------------------|--------------|
| 20 Ivory White | 28 Blue |
| 21 Natural Cherry | 29 Grey |
| 22 Natural Beech | 30 Turquoise |
| 24 Yellow | 31 Chocolate |
| 25 Orange | 33 Pale Rose |
| 26 Red | |

HI-COLLAR

Hi-Collar

Designed by:
Ray Power

Inspired by the traditional stiff shirt collar of old, Ray Power designed the Hi-Collar wall light. This small and simple lamp casts an indirect light in subdued tones both upwards and downwards, while the single piece of bent wood veneer diffuses a warming glow. There is no preening or primping, just a straightforward, minimalistic and unobtrusive light. It is a light perfectly suited to quiet spaces in homes and hotels, studios and eateries.

● HI-COLLAR - WALL | 20 Ivory White Wood Veneer. "Le Meridien" Hotel. Tarragona, Spain.





● **HI-COLLAR - WALL** | 21 Natural Cherry Wood Veneer.
 "Palau de Casavells". Girona, Spain.

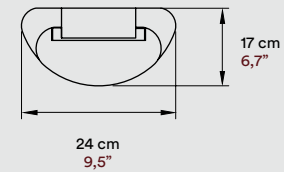
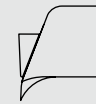
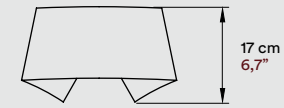

MATERIALS & COMPONENTS

Wood Veneer Shade

Metal Back Plate

LIGHT SOURCE

120 - 277V
 LED Integrated
 Dimmable 0-10V

Class I

120 - 277V
 LED Integrated
 Dimmable 0-10V & TRIAC

FINISHES

WOOD VENEER

- | | |
|-------------------|--------------|
| 20 Ivory White | 28 Blue |
| 21 Natural Cherry | 29 Grey |
| 22 Natural Beech | 30 Turquoise |
| 24 Yellow | 31 Chocolate |
| 25 Orange | 33 Pale Rose |
| 26 Red | |

HIDE &



Hide & Seek

New
Lamp

Suspension
Wall

Designed by:
Ray Power

The Elusive Light. Now you see me, now you don't. Ray Power presents a geometric pattern format which is applicable to a whole variety of shades. Using his talent for designing infinite shapes Ray has once again surprised us with this double layered pattern that transforms into a quasi three dimensional fabric when illuminated. Applied in a wall sconce and a ceiling light Hide & Seek provides a fascinating alternative as a veneer finish giving the lamp an on/off personality.

SEEK

• **HIDE & SEEK - WALL**
20 Ivory White Wood Veneer. "Casa en la Huerta".
Valencia, Spain. Architect: Ramón Esteve Estudio.



● **HIDE & SEEK - SUSPENSION** | 20 Ivory White Wood Veneer.

SUSPENSION

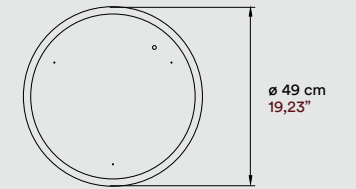
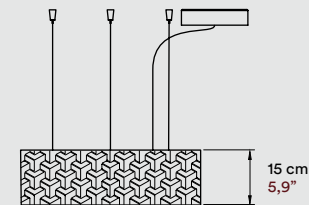

WALL

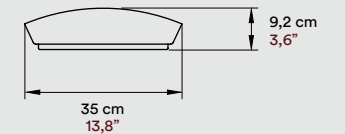
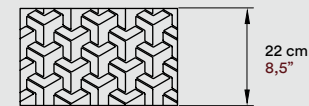

MATERIALS & COMPONENTS

Wood Veneer Shade

SUSPENSION
Top & Bottom Acrylic Diffuser

Metal Canopy

3 Steel Cables
2 m drop 8 ft drop

Electrical Cable
2 m drop 8 ft drop

WALL
Bottom & Upper Acrylic Diffuser

Metal Back Plate

FINISHES

WOOD VENEER "HIDE & SEEK"



● 20 Ivory White

LIGHT SOURCE

120 - 277V
SUSPENSION LED Integrated
Dimmable 0-10V, Bluetooth or DALI

Class 1 CE

WALL LED Integrated Dimmable 0-10V

120 - 277V
SUSPENSION LED Integrated
Dimmable 0-10V & TRIAC

UL US

WALL LED Integrated Dimmable

ADA Compliant

I - CLUB



I-Club

Suspension
Ceiling
Wall
Table

Created by Burkhard Dämmer, the I-Club is designed with clean architectural lines and a longer form that will illuminate its surroundings with understated elegance. An innovative lighting series, I-Club has a symmetrical beauty that is replicated across a number of models: suspension, wall, ceiling, floor and table.

Designed by:
Burkhard Dämmer

● **I-CLUB SLIM - SUSPENSION & TABLE**
21 Natural Cherry Wood Veneer. "Palau de Casavells". Girona, Spain.

- **I-CLUB SLIM - SUSPENSION** | 21 Natural Cherry Wood Veneer.
"Villa El Nido". Marbella, Spain.



I-CLUB

SUSPENSION

BURKHARD DÄMMER

SHORT SLIM

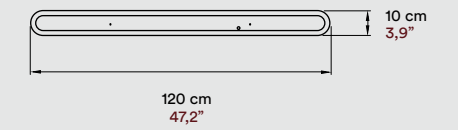
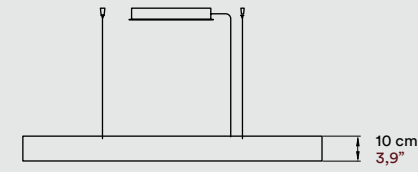

LONG SLIM

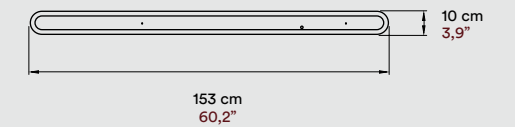
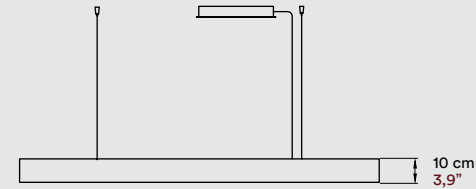

MATERIALS & COMPONENTS

Wood Veneer Shade

Top & Bottom Acrylic Diffuser

Metal Canopy

2 Steel Cables
2 m drop 8 ft drop

Electrical Cable
2 m drop 8 ft drop

LIGHT SOURCE

120 - 277V
LED Integrated
Dimmable 0-10V, Bluetooth or DALI

Class I

120 - 277V
LED Integrated
Dimmable 0-10V & TRIAC

FINISHES

WOOD VENEER

- | | |
|-------------------|--------------|
| 20 Ivory White | 28 Blue |
| 21 Natural Cherry | 29 Grey |
| 22 Natural Beech | 30 Turquoise |
| 24 Yellow | 31 Chocolate |
| 25 Orange | 33 Pale Rose |
| 26 Red | |

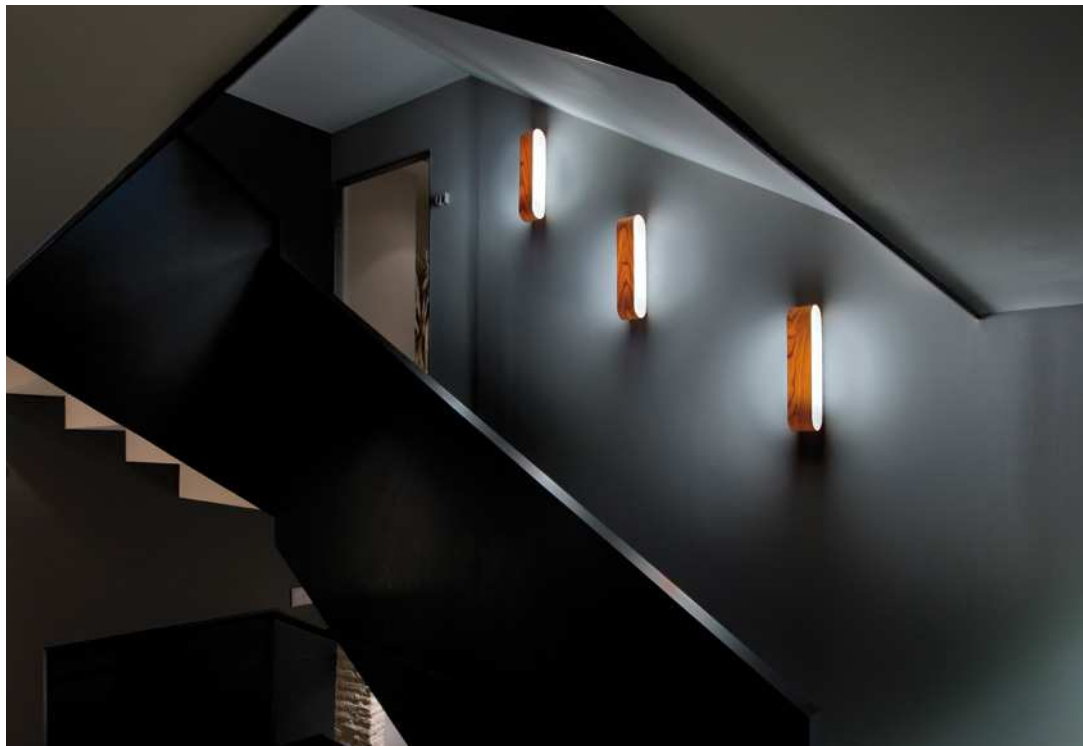

● **I-CLUB - SMALL WALL**
21 Natural Cherry Wood Veneer.
"Caro" Hotel. Valencia, Spain.

● **I-CLUB SLIM - LARGE WALL**
21 Natural Cherry Wood Veneer.
"Palau de Casavells". Girona, Spain.



I-CLUB

WALL

BURKHARD DÄMMER

SMALL

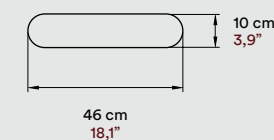

SLIM

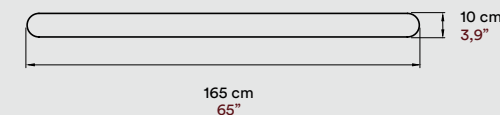

MATERIALS & COMPONENTS

Wood Veneer Shade

Bottom & Upper Acrylic Diffuser

Metal Back Plate

LIGHT SOURCE

120 - 277V
LED Integrated
Dimmable 0-10V, Bluetooth or DALI

Class I

120 - 277V
LED Integrated
Dimmable 0-10V & TRIAC

ADA Compliant

FINISHES

WOOD VENEER

- | | |
|-------------------|--------------|
| 20 Ivory White | 28 Blue |
| 21 Natural Cherry | 29 Grey |
| 22 Natural Beech | 30 Turquoise |
| 24 Yellow | 31 Chocolate |
| 25 Orange | 33 Pale Rose |
| 26 Red | |

LARGE



MATERIALS & COMPONENTS

Wood Veneer Shade

Frontal Acrylic Diffuser

Metal Back Plate

LIGHT SOURCE

120 - 277V
LED Integrated
Dimmable 0-10V, Bluetooth or DALI

Class I

120 - 277V
LED Integrated
Dimmable 0-10V or TRIAC

FINISHES

WOOD VENEER

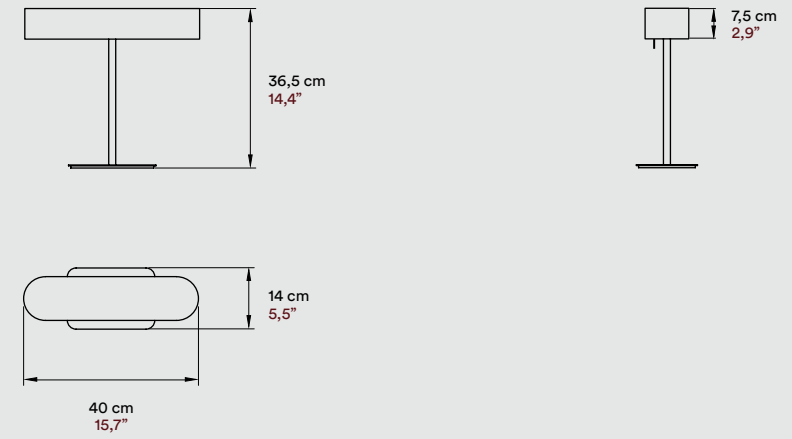

MATERIALS & COMPONENTS

Wood Veneer Shade

Bottom & Upper Acrylic Diffuser

Metal Stem & Base

Touch on/off Dimming Rod

Electrical Cable
145 cm 57"

LIGHT SOURCE

LED Integrated Dimmable

LED Integrated Dimmable

Class II

FINISHES

WOOD VENEER



Class II

ICON

Icon

Designed by:
Burkhard Dämmer

Set within a brushed nickel frame, the Icon lamp smacks of a three-dimensional artwork with an industrial bent. From its front aspect, the lamp is perfectly even, its metal surround flush with the wood veneer shade. Move around the lamp and the Icon's profile changes, its form more rounded, having depth.

The close proximity of metal, wood and light give rise to a well proportioned lamp, where the individual elements knit together to define an iconic form. Viewed from different angles, the Icon is the artful depiction of a striking lamp.

- **ICON - SUSPENSION**
22 Natural Beech Wood Veneer.
"Villa El Nido". Marbella, Spain.





● **ICON - SUSPENSION** | 21 Natural Cherry Wood Veneer.

ICON

SUSPENSION

BURKHARD DÄMMER

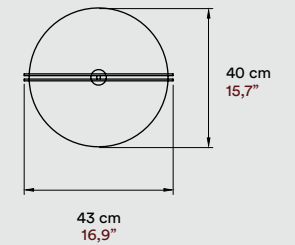
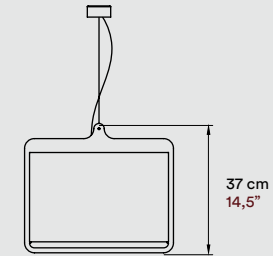

MATERIALS & COMPONENTS

Wood Veneer Shade

Metal Frame & Canopy

Steel Cable
2 m drop 8 ft drop

Electrical Cable
2 m drop 8 ft drop

LIGHT SOURCE

220 - 250V
Bulb E27

Class I

120 - 277V
Bulb E26 or GU24



FINISHES

WOOD VENEER

- | | |
|-------------------|--------------|
| 20 Ivory White | 28 Blue |
| 21 Natural Cherry | 29 Grey |
| 22 Natural Beech | 30 Turquoise |
| 24 Yellow | 31 Chocolate |
| 25 Orange | 33 Pale Rose |
| 26 Red | |

LI



Link

Small Suspension
Large Suspension
Floor

Designed by:
Ray Power

Designed by Ray Power, Link appears exceptionally dashing in its stacked wood veneer Möbius strips. In mathematics, the Möbius strip is a surface with one continuous side, meaning the Link light is not only handsome, but discerning too.

With its billowy, cloud-like structure, Link is decidedly easy on the eye. Punctiliously crafted, the lamp's floating form is a clever illustration of wood's significant potential in lighting design. Link is available as a suspension lamp in three versions: small, large and modular. In addition, Link is an attractive floor lamp, its billowy mass poised on the top of a chrome tower-like base.

In Link, there is an obvious 'link' between brilliance and beauty, form and function.

• **LINK - LARGE SUSPENSION**
21 Natural Cherry Wood Veneer.
"Bachelor loft". Toronto, Canada.
Design: Stephane Chamard.
Photographie by Lisa Petrole.

INK



• **LINK - LARGE SUSPENSION**
21 Natural Cherry Wood Veneer.

• **LINK - LARGE SUSPENSION**
24 Yellow Wood Veneer.
Architects: Luca Construction and Design, Inc Pennsylvania.

LINK

SUSPENSION

RAY POWER

SMALL

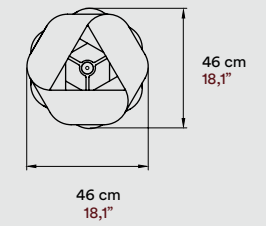
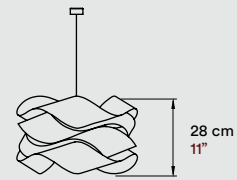

LARGE

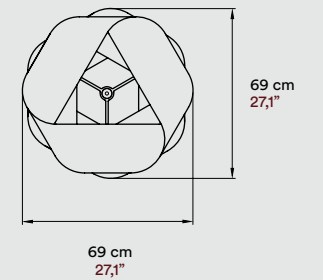
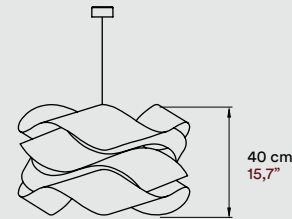

MATERIALS & COMPONENTS

Wood Veneer Shade

Metal Tripod & Canopy

Electrical Cable
2 m drop 8 ft drop

LIGHT SOURCE

220 - 250V Class I CE
Bulb E27

120 - 277V UL US
Bulb E26 or GU24

FINISHES

WOOD VENEER

- | | |
|---|--|
|  20 Ivory White |  28 Blue |
|  21 Natural Cherry |  29 Grey |
|  22 Natural Beech |  30 Turquoise |
|  24 Yellow |  31 Chocolate |
|  25 Orange |  33 Pale Rose |
|  26 Red | |

AWARDS

-  **DESIGN PLUS**
Chicago Frankfurt



LINK CHAIN

SUSPENSION

RAY POWER & MARIVÍ CALVO

SMALL

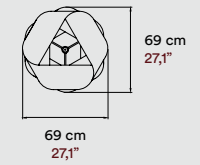
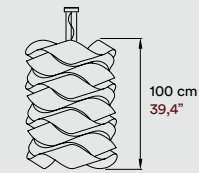

MEDIUM

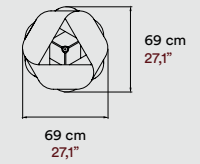
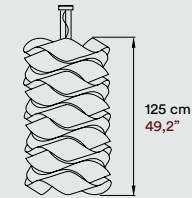

LARGE

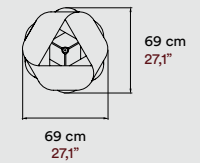
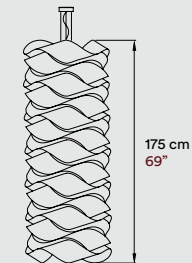

MATERIALS & COMPONENTS

Wood Veneer Shade

Metal Tripod & Canopy

3 Steel Cables
2 m drop 8 ft drop

Electrical Cable
2 m drop 8 ft drop

LIGHT SOURCE

220 - 250V
3, 4 or 6 Bulbs E27

Class I CE

120 - 277V
3, 4 or 6 Bulbs E26 or GU24



FINISHES

WOOD VENEER

- | | |
|---|--|
|  20 Ivory White |  28 Blue |
|  21 Natural Cherry |  29 Grey |
|  22 Natural Beech |  30 Turquoise |
|  24 Yellow |  31 Chocolate |
|  25 Orange |  33 Pale Rose |
|  26 Red | |

- **LINK CHAIN SMALL - SUSPENSION**
20 Ivory White Wood Veneer.
HVB Freising Invest by Bottler & Luts Architekten BDA.

As the Link Chain is a modular system, it allows for different lengths and combination of Link shade modules upon request.



• LINK - FLOOR | 20 Ivory White Wood Veneer & Brushed Nikel Metal.

LINK

FLOOR

RAY POWER

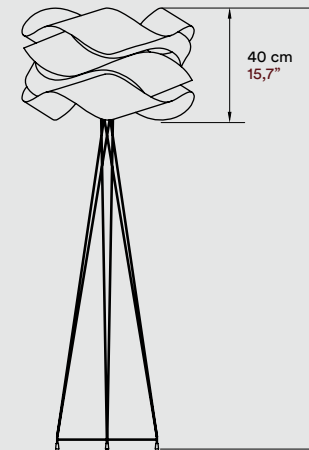

177 cm
69,7"

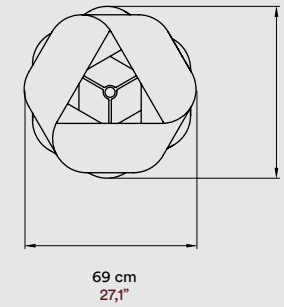

69 cm
27,1"

69 cm
27,1"

MATERIALS & COMPONENTS

Wood Veneer Shade

Metal Tripod & Base

Electrical Cable with Dimming Switch
185 cm 53"

LIGHT SOURCE

220 - 250V
Bulb E27

Class II

120V
Bulb E26

FINISHES

WOOD VENEER

- | | |
|-------------------|--------------|
| 20 Ivory White | 28 Blue |
| 21 Natural Cherry | 29 Grey |
| 22 Natural Beech | 30 Turquoise |
| 24 Yellow | 31 Chocolate |
| 25 Orange | 33 Pale Rose |
| 26 Red | |

METAL

- | | |
|--------|---------------|
| Chrome | *Matt Ivory |
| | *Matt Black |
| | *Black Nickel |
| | *Gold |
| | *On Request |

MINIMIKADO



MiniMikado

Designed by:
Miguel Herranz

- **MINIMIKADO- SUSPENSION**
24 Yellow Wood Veneer. "Villa El Nido". Marbella, Spain.

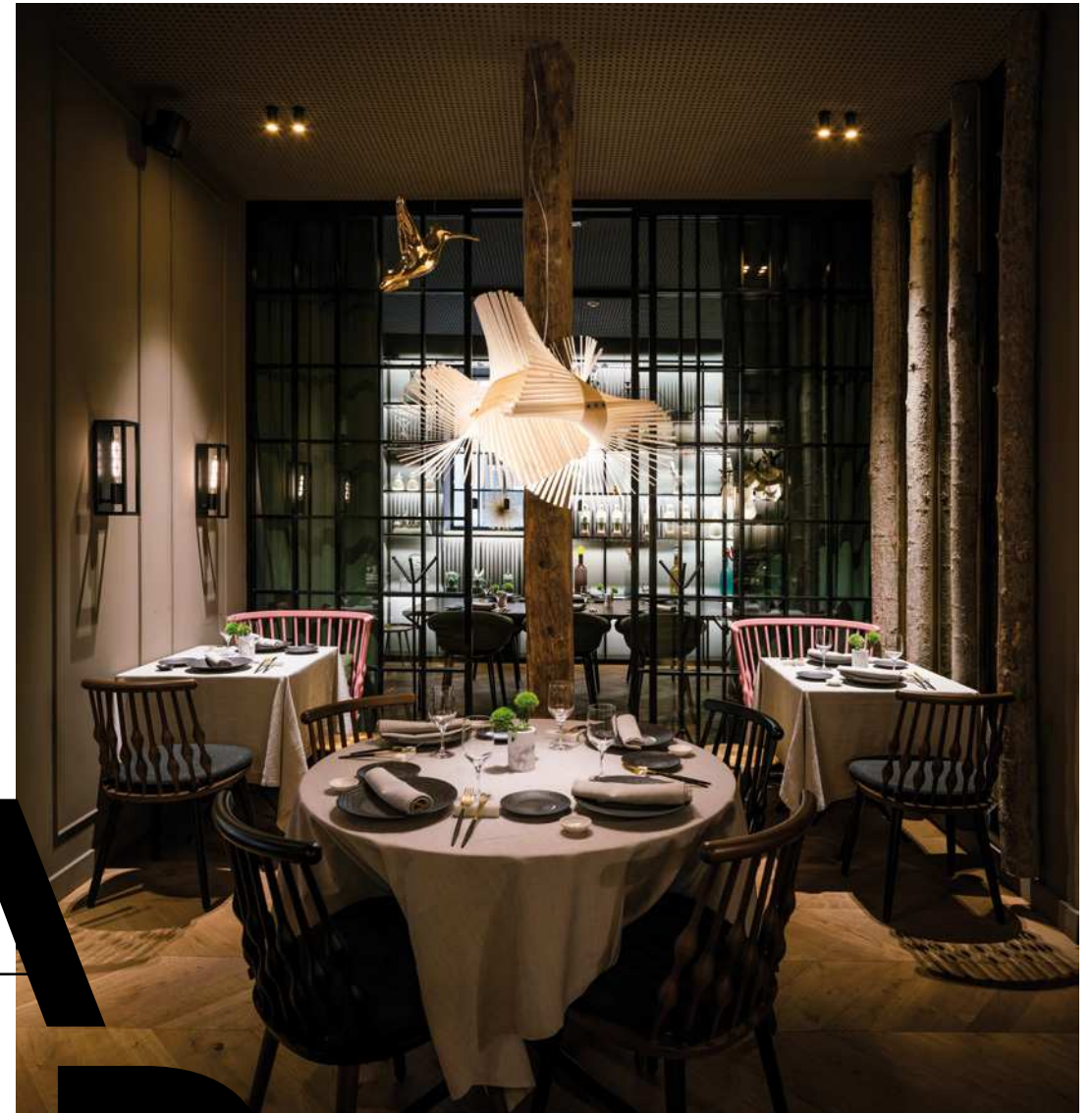

The Mikado light takes its names from the classic pick-up-sticks game, where sticks are bundled together and when released, fall in a circular jumble. A radiant light, Mikado's wood veneer strips spread outwards, in a manner evocative of a bird's plumage. Cleverly engineered, the Mikado's form is both chaotic and harmonious at the same time.

Designed by Miguel Herranz, the Mikado is a free spirit, possessing an air of nonchalance and a teasingly impish swagger. It is a light whose profile is like a coruscating kaleidoscope of pattern.

- **MINIMIKADO -SUSPENSION**
20 Ivory White Wood Veneer. "Alameda" Restaurant. Madrid, Spain.

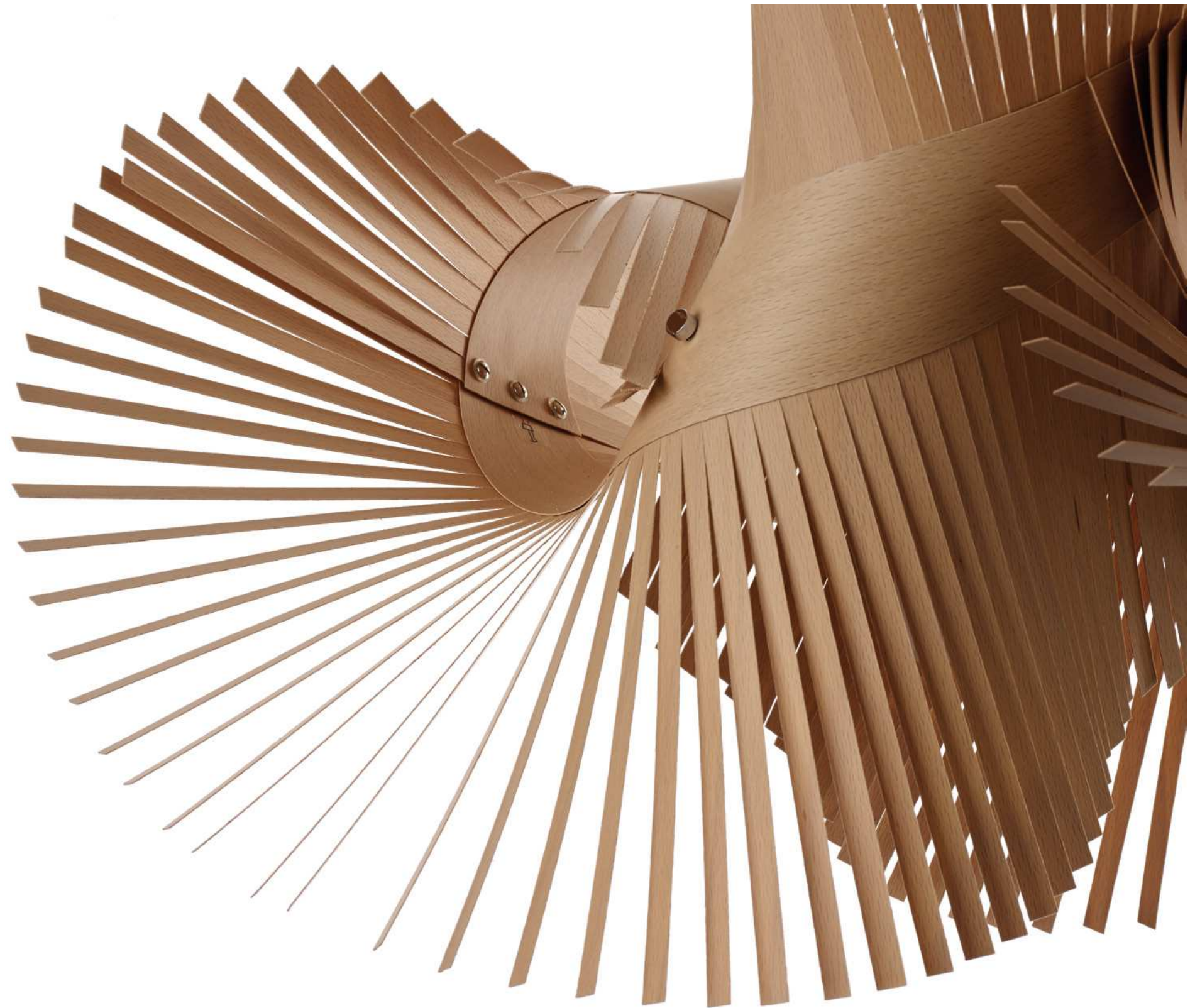

• **MINIMIKADO - SUSPENSION**
22 Natural Beech Wood Veneer.

- **MINIMIKADO - SUSPENSION**
22 Natural Beech Wood Veneer.
"Caro" Hotel. Valencia, Spain.



MINIMIKADO

SUSPENSION

MIGUEL HERRANZ

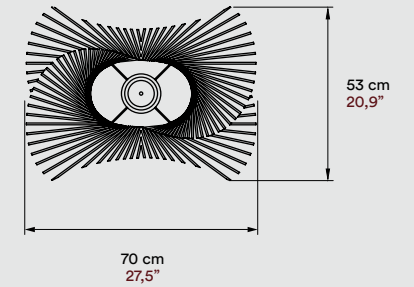
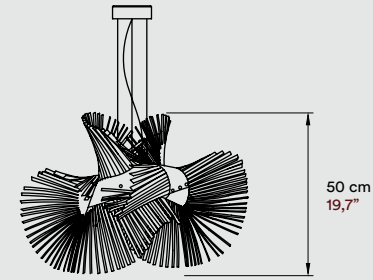

MATERIALS & COMPONENTS

Wood Veneer Shade

Metal Structure & Canopy

3 Steel Cables
2 m drop 8 ft drop

Electrical Cable
2 m drop 8 ft drop

LIGHT SOURCE

220 - 250V
Bulb E27

Class I

120 - 277V
Bulb E26 or GU24

FINISHES

WOOD VENEER

- | | |
|-------------------|--------------|
| 20 Ivory White | 28 Blue |
| 21 Natural Cherry | 29 Grey |
| 22 Natural Beech | 30 Turquoise |
| 24 Yellow | 31 Chocolate |
| 25 Orange | 33 Pale Rose |
| 26 Red | |

AWARDS



DESIGN PLUS

Chicago

Frankfurt

NEW



Designed by:
Ray Power

New Wave comprises of two interlocking interior and exterior wood veneer sheets. Differing in colour to the exterior sheets, the interior sheets's edge juts out, creating a clever design feature that enhances the New Wave's profile. The resulting composition is well-proportioned and fluid, giving the New Wave a smooth, free-flowing countenance.

New Wave

- **NEW WAVE - SUSPENSION**
28 Blue & 24 Yellow Wood Veneer.
"Ma Khin" Cafe. Valencia, Spain.

NEW



● **NEW WAVE - SUSPENSION**
21 Natural Cherry & 20 Ivory White Wood Veneer.

NEW WAVE

SUSPENSION

RAY POWER

LED

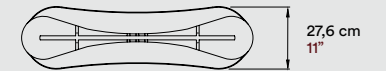
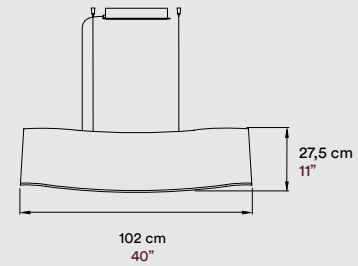

BULBS

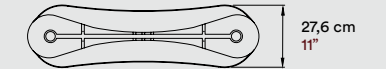
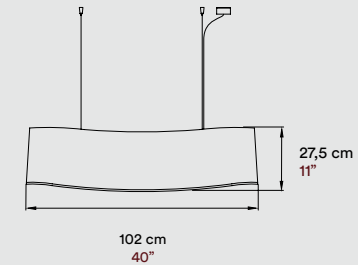

MATERIALS & COMPONENTS

Wood Veneer Shade









Metal Structure & Canopy

4 Steel Cables
2 m drop 8 ft drop

Electrical Cable
2 m drop 8 ft drop

FINISHES

WOOD VENEER COMBINATIONS

Exterior		Interior	
 21 Cherry	with	 20 Ivory White	
 26 Red	with	 24 Yellow	
 28 Blue	with	 24 Yellow	
 30 Turquoise	with	 24 Yellow	

LIGHT SOURCE

120 - 277V
LED Integrated
Dimmable 0-10V, Bluetooth or DALI
or
220 - 250V
2 Bulbs E27 W

Class I 

120 - 277V
LED Integrated
Dimmable 0-10V & TRIAC
or
120 - 277V
2 Bulbs E26 or GU24



AWARDS



Chicago

N

U

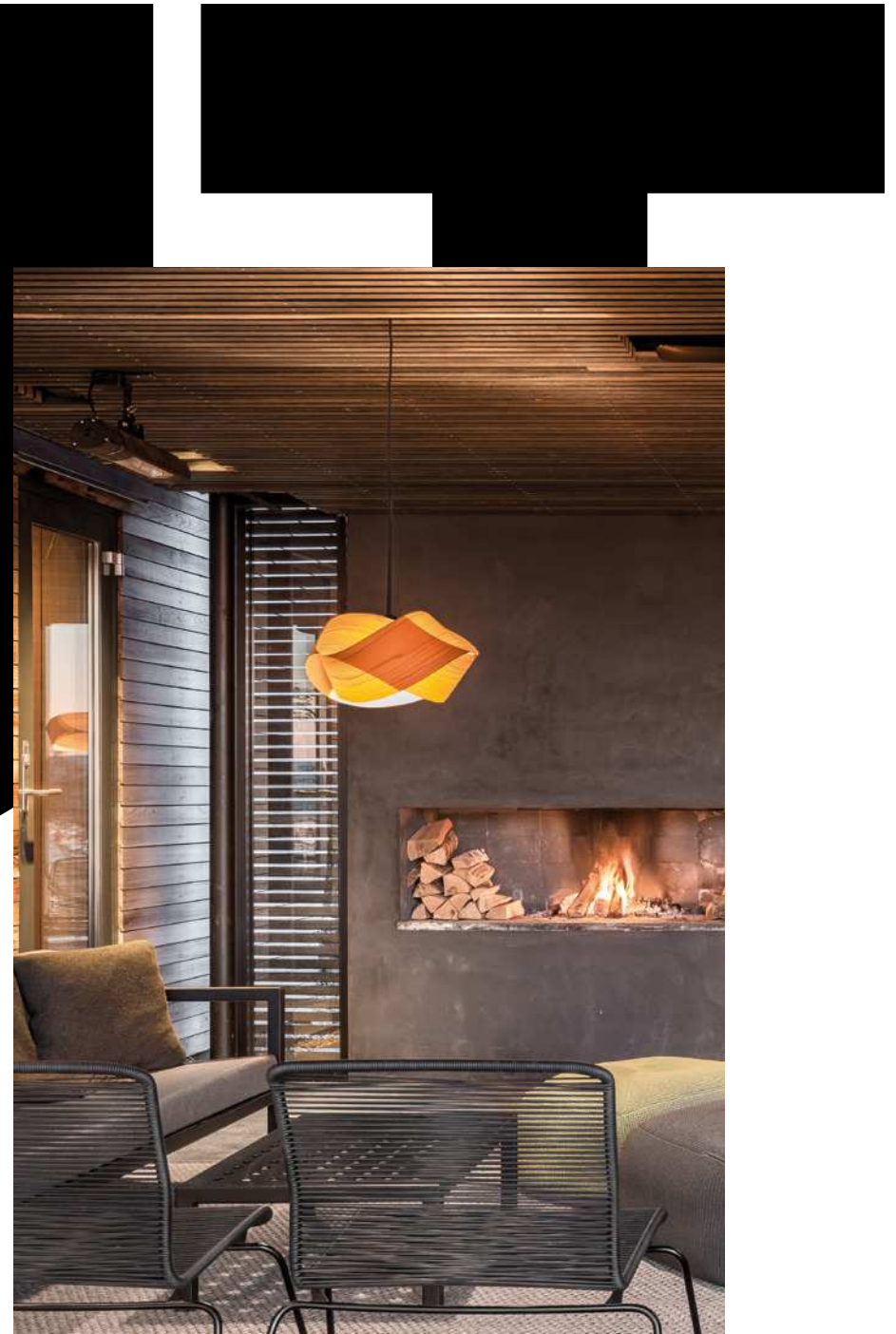

Nut

Designed by:
Ray Power

Nut is an unfussy and modest knot of light, its elegant form made by the twisting and looping of wood veneer. A small and simple pendant, the Nut lamp is ideal when seeking to achieve a relaxed ambience.

The Nut lamp has two different forms, as determined by the direction of torsion—that is to say, the way in which the wood veneer is twisted.

- **NUT - SUSPENSION**
22 Natural Beech Wood Veneer.
“Malangen Retreat”. Architects: Snorre Stinessen Arkitektur Norway.

● **NUT - SUSPENSION**

20 Ivory White Wood Veneer.
 "Villa El Nido". Marbella, Spain.
 Architects: A-cero Atchitects.



NUT

SUSPENSION

RAY POWER

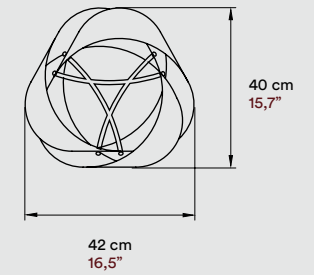
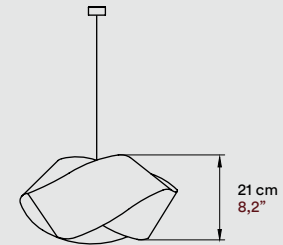

MATERIALS & COMPONENTS

Wood Veneer Shade

Metal Tripod & Canopy

Electrical Cable
 2 m drop 8 ft drop

LIGHT SOURCE

220 - 250V
 Bulb E27

Class I

120 - 277V
 Bulb E26 or GU24

FINISHES

WOOD VENEER

- | | |
|-------------------|--------------|
| 20 Ivory White | 28 Blue |
| 21 Natural Cherry | 29 Grey |
| 22 Natural Beech | 30 Turquoise |
| 24 Yellow | 31 Chocolate |
| 25 Orange | 33 Pale Rose |
| 26 Red | |

O

R

B

Orbit

Designed by:
Miguel Herranz

With its thoughtful air, the ovalesque Orbit light will decorate any wall with quiet self-assurance. Created by Spanish designer Miguel Herranz, Orbit is an unfussy lamp whose shape is handmade by twisting a piece of wood veneer. Two designs are feasible, depending on the direction of torsion—that is how the wood veneer is twisted.

Light from the Orbit is diffused both upwards and downwards via its two apertures and an inner glow radiates outwards, accentuating the beauty of the timber veneer grain. In essence, just as the earth is in orbit around the sun, light is in orbit around the Orbit.

• ORBIT - WALL | 20 Ivory White Wood Veneer. "Caro" Hotel. Valencia, Spain.

T





● **ORBIT - WALL**
20 Ivory White Wood Veneer.
"Caro" Hotel. Valencia, Spain.

ORBIT

WALL

MIGUEL HERRANZ

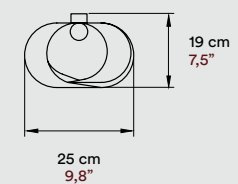
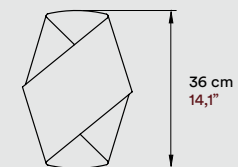

MATERIALS & COMPONENTS

Wood Veneer Shade

Metal Back Plate

LIGHT SOURCE

220 - 250V Class I CE
Bulb E27

120 - 277V UL US
Bulb E26

FINISHES

WOOD VENEER

- | | |
|---|--|
|  20 Ivory White |  28 Blue |
|  21 Natural Cherry |  29 Grey |
|  22 Natural Beech |  30 Turquoise |
|  24 Yellow |  31 Chocolate |
|  25 Orange |  33 Pale Rose |
|  26 Red | |

PAISLEY

Designed by:
Luis Eslava Studio

The intricate pattern on the Paisley screen brings to mind the famous droplet-shaped paisley motif, with its distinctive curving decoration. Paisley is an artistic modular floor standing partition, handmade from cherrywood veneer. By connecting several Paisley modules, one can create an aesthetically pleasing and

decorative room divider. In both natural and artificial light, the Paisley screen's weaving and flowing patterns cast exquisite swirling shadows that delight the eye. With its Zen-like quality and delicate woodwork, the prepossessing Paisley screen could be straight out of a traditional Japanese house or ryokan.

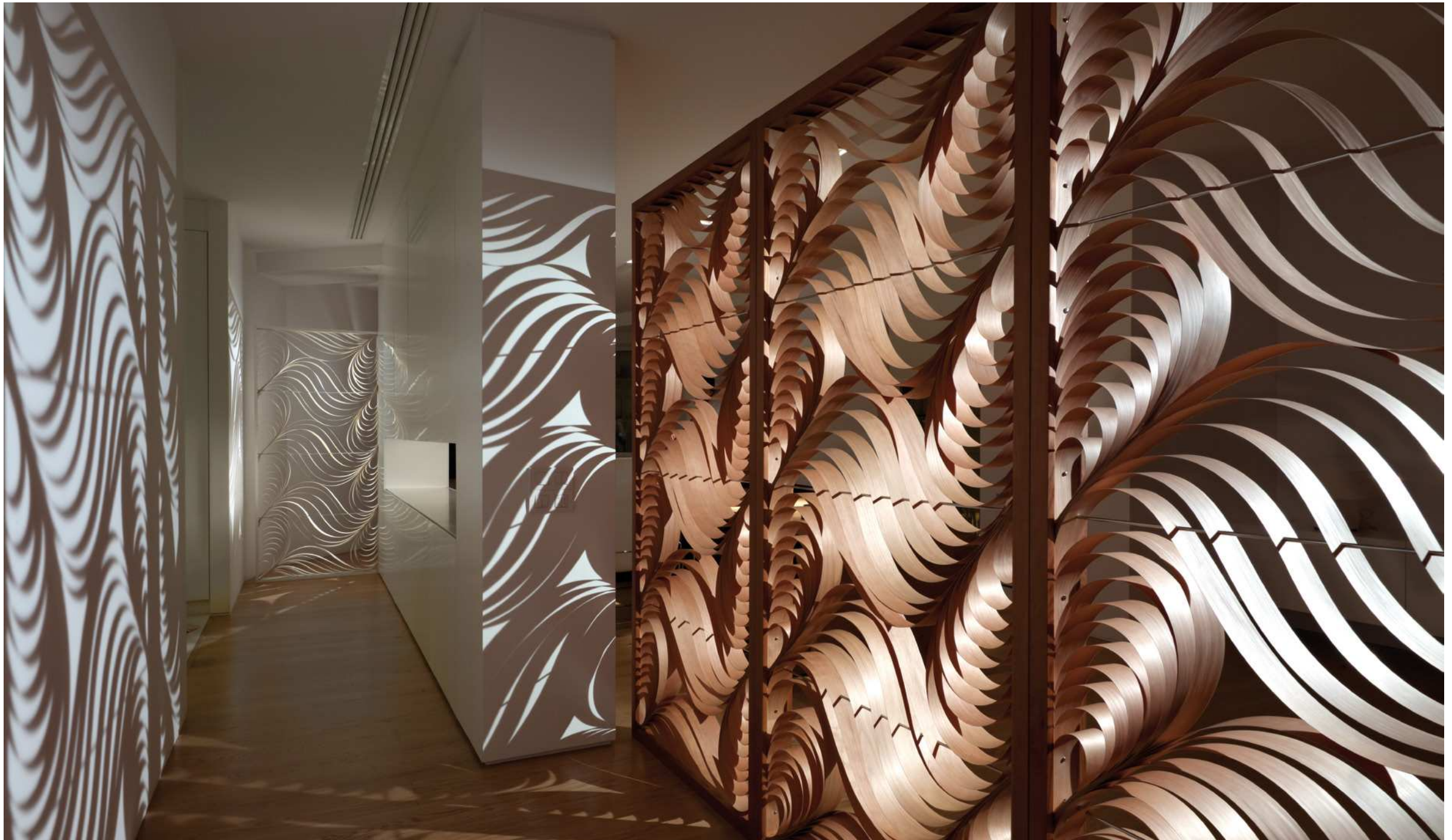



● PAISLEY - SCREEN
21 Natural Cherry Wood Veneer & Natural Cherry Frame.

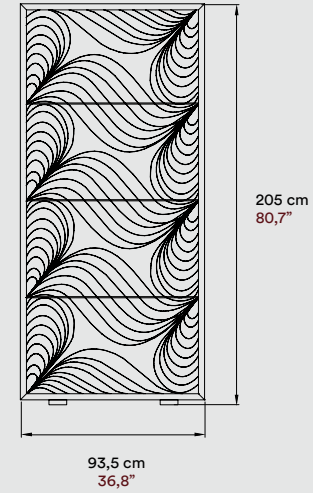

MATERIALS & COMPONENTS

Wood Veneer Screen

Wood Frame & Feet

Joining system for multiple screen set up

AWARDS



Chicago

FINISHES

WOOD VENEER

- 20 Ivory White
- 28 Blue
- 21 Natural Cherry
- 29 Grey
- 22 Natural Beech
- 30 Turquoise
- 24 Yellow
- 31 Chocolate
- 25 Orange
- 33 Pale Rose
- 26 Red

WOOD FRAME

- Matt White
- Natural Cherry

Piknik

Designed by:
Macalula

The portable Piknik lamp is happy both indoors and outdoors. Piknik is handsome, adaptable and smart. Its cleverly designed tubular wood veneer lampshade hangs freely, while its rechargeable battery will keep going for up to eight hours. Befitting a modern lifestyle, Piknik also features touch sensor dimming. All charged up and ready to go, simply take the Piknik's handy handle and happily untethered, it will feel at ease in your gracious company.



**P
I
K
N
I
K**

• PIKNIK - CORDLESS | 24 Yellow Wood Veneer.



• PIKNIK - CORDLESS
22 Natural Beech Wood Veneer.

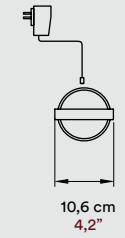
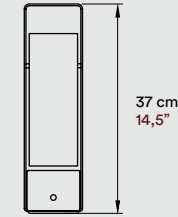

MATERIALS & COMPONENTS

Wood Veneer Shade

Acrylic Diffuser

Metal Base & Handle

Rechargeable Battery
7 Hours Autonomy at 100% Power

IN Charge
USB type C

LIGHT SOURCE

LED Integrated Dimmable

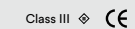

LED Integrated Dimmable

FINISHES

WOOD VENEER

- | | |
|-------------------|--------------|
| 20 Ivory White | 28 Blue |
| 21 Natural Cherry | 29 Grey |
| 22 Natural Beech | 30 Turquoise |
| 24 Yellow | 31 Chocolate |
| 25 Orange | 33 Pale Rose |
| 26 Red | |

AWARDS



Germany



Germany

OSPLEG

W

L

R



Pleg

Designed by:
Yonoh Creative Studio

The Pleg wall light resembles a folded sheet of paper, putting one in mind of a decorative piece of origami. Designed by Yonoh Creative Studio, Pleg is perfect for cosy spaces, bedsides and alcoves, owing to its small size.

Pleg can be installed in four different positions, with light diffused horizontally or vertically from its open sides. At the same time, light emanates warmly through the attractive bent wood veneer. Straightforward, smart and subtle, the Pleg light is modest and charming.

• **PLEG - WALL**
20 Ivory White Wood Veneer.
"Caro" Hotel. Valencia, Spain.



● **PLEG - WALL**
33 Pale Rose Wood Veneer.
"La Monella" Jewellers.
Valencia, Spain.

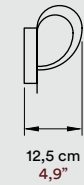
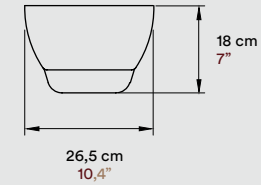

MATERIALS & COMPONENTS

Wood Veneer Shade

Acrylic Side Diffuser

Metal Back Plate

LIGHT SOURCE

120 - 277V
LED Integrated
Dimmable 0-10V
or

220 - 250V
Bulb GX53

Class I

120 - 277V
LED Integrated
Dimmable 0-10V & TRIAC
or

120V
Bulb GX53

FINISHES

WOOD VENEER

- | | |
|-------------------|--------------|
| 20 Ivory White | 28 Blue |
| 21 Natural Cherry | 29 Grey |
| 22 Natural Beech | 30 Turquoise |
| 24 Yellow | 31 Chocolate |
| 25 Orange | 33 Pale Rose |
| 26 Red | |

AWARDS



Chicago



reddot design award
Germany

POD&

Medium

Designed by:
Burkhard Dämmer

Kin to the Poppy pendant, Pod is a vertically elongated and ellipse-like orbit of light whose body is made up of a repeated series of wood veneer strips. Different from the Poppy, a small gap between each strip on the Pod allows just a peek at the light within.

The Pod is appreciably unostentatious, having a fresh manner that smiles and illuminates its surroundings with an altruistic sense of cool. It is a pendant that works well discretely or as part of a striking cluster of Podand Poppy lights.

POPPY

Small
Medium

Kin to the Pod pendant, the slightly squat and spherical Poppy lamp is made up of a repeated series of wood veneer strips. Different from the Pod, a larger gap between each strip on the Poppy emits light with a greater luminosity, its mature form sparkling in full bloom.

Compared to the Pod pendant, Poppy is like the mature older sibling, with a fully developed form that lends weight to its mellow disposition. Both the Poppy and Pod lamps work well in unison, able to form impressive cloud-like clusters.



● POD & POPPY - SUSPENSION | 21, 28, 30 & 31 Wood Veneer. "Emocions Sorli" Restaurant. Interior Design: DyD Interiorismo. Photo by Marcela Grassi.



• **POD - MEDIUM SUSPENSION** | 20 Ivory White Wood Veneer. "Alameda" Restaurant. Madrid, Spain.

POPPY & POD

SUSPENSION

BURKHARD DÄMMER

POPPY SMALL

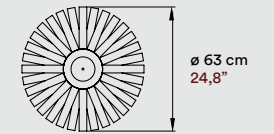
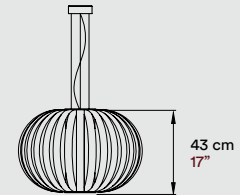

POPPY MEDIUM

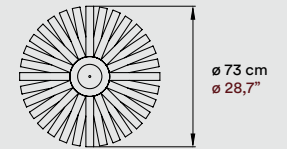
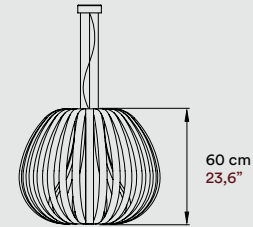

POD MEDIUM

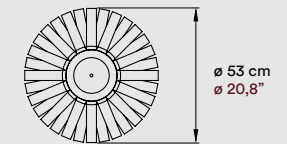
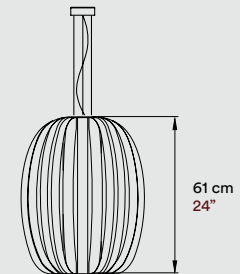

MATERIALS & COMPONENTS

Wood Veneer Shade

Metal Canopy

3 Steel Cables
2 m drop 8 ft drop

Electrical Cable
2 m drop 8 ft drop

LIGHT SOURCE

220 - 250V
Bulb E27

Class I

120 - 277V
Bulb E26 or GU24

FINISHES

WOOD VENEER

- | | |
|-------------------|--------------|
| 20 Ivory White | 28 Blue |
| 21 Natural Cherry | 29 Grey |
| 22 Natural Beech | 30 Turquoise |
| 24 Yellow | 31 Chocolate |
| 25 Orange | 33 Pale Rose |
| 26 Red | |

RAINDROP

Raindrop

Small
Medium

Designed by:
Javier Herrero Studio

Visualise the simple beauty of a stationary raindrop, a small and glistening droplet that instead of falling, remains in a state of suspended animation. While Tina couldn't stand the rain against her window, the Raindrop pendant is a welcome sight.

Javier Herrero imagined and designed the Raindrop pendant, its suspended shade made using strips of wood veneer that contain a glowing ball. Available in small and medium sizes, the Raindrop's form is playful and poised. It is a light that will hang gracefully by itself and is especially pleasing and engaging when arranged in a group formation.

● RAINDROP - MEDIUM SUSPENSION | 20 Ivory White Wood Veneer.





• **RAINDROP
SMALL SUSPENSION**
21 Natural Cherry
Wood Veneer.

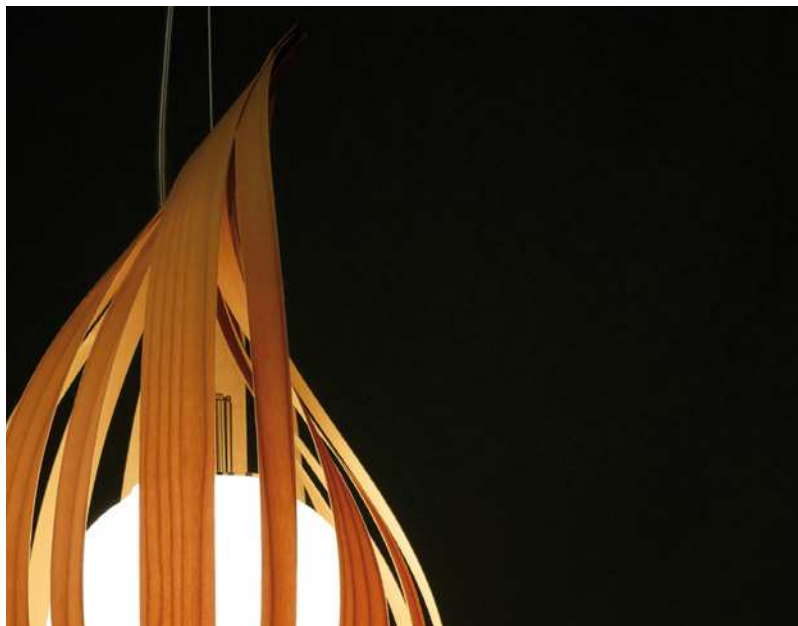

• **RAINDROP - MEDIUM
SUSPENSION**
21 Natural Cherry
Wood Veneer.

RAINDROP

SUSPENSION

JAVIER HERRERO STUDIO

SMALL

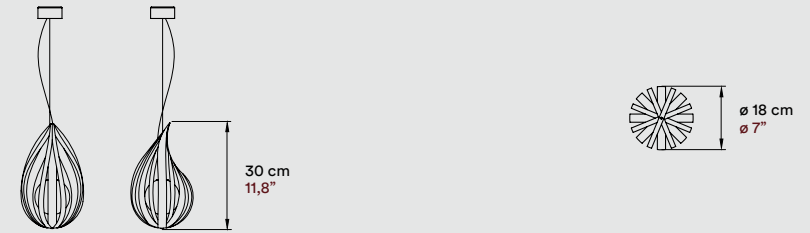

MEDIUM

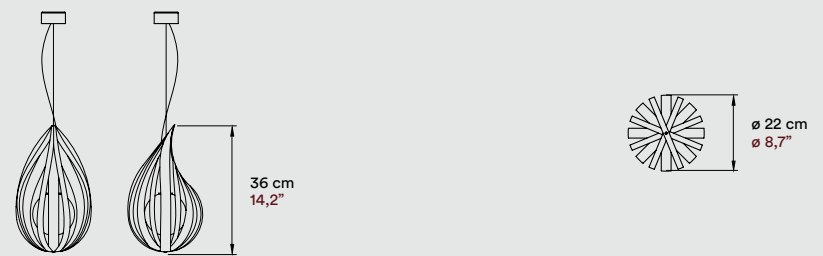

MATERIALS & COMPONENTS

Wood Veneer Shade

Frosted Glass Ball

Metal Canopy

Electrical Cable
2 m drop 8 ft drop

Steel Cable
2 m drop 8 ft drop

LIGHT SOURCE

220 - 250V
Bulb G9

Class I

120V
Bulb G9

FINISHES

WOOD VENEER

- | | |
|-------------------|--------------|
| 20 Ivory White | 28 Blue |
| 21 Natural Cherry | 29 Grey |
| 22 Natural Beech | 30 Turquoise |
| 24 Yellow | 31 Chocolate |
| 25 Orange | 33 Pale Rose |
| 26 Red | |

SATURNIA

The Saturnia pendant is reminiscent of Saturn's system of planetary rings. A truly handsome and enchanting light, its form is one that captivates the eye: similar to the way in which we gaze wondrously at stars in the night sky.

Saturnia balances both indirect and direct lighting with aplomb. Its circular wood veneer spreads warm light outwards, while its Plexiglas diffuser provides the perfect direct light necessary for task-oriented jobs and for social or work environments. Saturnia makes a bold statement as a solo light or when suspended in a group of varied sizes.

Small
Medium
Large

Designed by:
Oskar Cerezo



• **SATURNIA**
MEDIUM SUSPENSION
21 Natural Cherry Wood
Veneer, "BNP Paribas Invest-
ment Partners". Architects:
Fokkema and Partners
Architecten Amsterdam.



SATURNIA

SUSPENSION

OSKAR CEREZO

SMALL

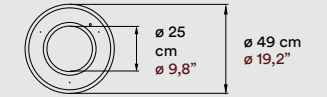
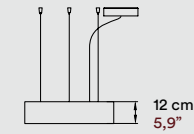

MEDIUM

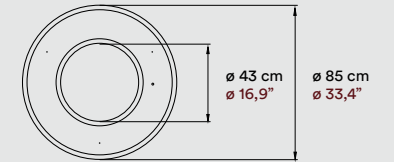
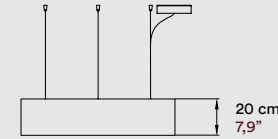

LARGE

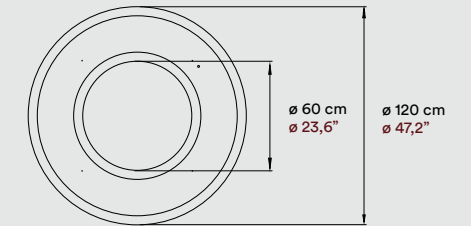
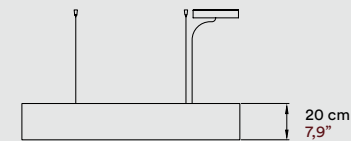

MATERIALS & COMPONENTS

Wood Veneer Shade

Top & Bottom Acrylic Diffuser

Metal Canopy

3 Steel Cables SMALL & MEDIUM

4 Steel Cables LARGE

2 m drop 8 ft drop

Electrical Cable

2 m drop 8 ft drop

FINISHES

WOOD VENEER

- | | |
|-------------------|--------------|
| 20 Ivory White | 28 Blue |
| 21 Natural Cherry | 29 Grey |
| 22 Natural Beech | 30 Turquoise |
| 24 Yellow | 31 Chocolate |
| 25 Orange | 33 Pale Rose |
| 26 Red | |

LIGHT SOURCE

120 - 277V

LED Integrated
Dimmable 0-10V, Bluetooth or DALI

Class I

120 - 277V

LED Integrated
Dimmable 0-10V & TRIAC

SPIRO

Spiro

Medium
Large

Designed by:
Remedios Simón

Op art (optical art) developed in the 1960s as an artistic style that used geometric shapes to generate optical illusions. With a nod to the genre, designer Remedios Simón created Spiro, a charismatic pendant whose frame contains a mass of irregular wood veneer spirals.

Available in 3 outer shell options (cherrywood or acrylic white or wblack), Spiro is an impressive light with an enchanting aura. Similar to op art, Spiro plays with the physiology and psychology of human perception, its charm utterly irresistible.

● SPIRO - LARGE SUSPENSION

Matt Black Outer Shell & 22 Natural Beech Wood Veneer.
"Caro" Hotel. Valencia, Spain.





● SPIRO - LARGE SUSPENSION | Matt Black Outer Shell & 29 Grey Wood Veneer.



• **SPIRO - LARGE SUSPENSION**
 Matt Black Outer Shell & 21 Natural Cherry Wood Veneer.
 "Villa El Nido". Marbella, Spain. Architects: A-cero Architects.

SPIRO

SUSPENSION

REMEDIOS SIMÓN

MEDIUM

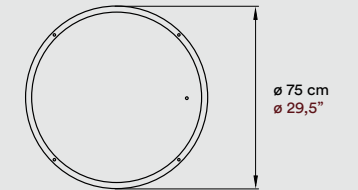
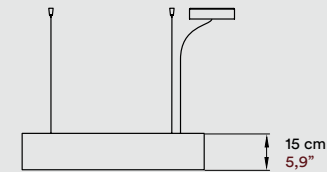

LARGE

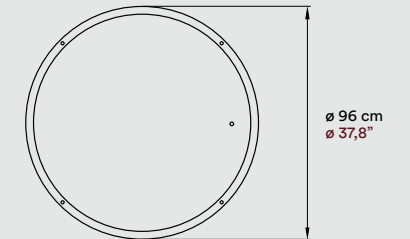
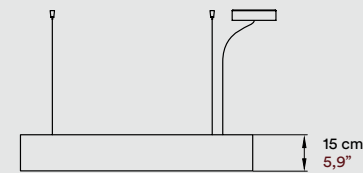

MATERIALS & COMPONENTS

Opaque Wood or Acrylic Outer Shell

Wood Veneer Spirals

Top & Bottom Diffuser

Metal Canopy

4 Steel Cables
 2 m drop 8 ft drop

Electrical Cable
 2 m drop 8 ft drop

LIGHT SOURCE

120 - 277V
 LED Integrated
 Dimmable 0-10V, Bluetooth or DALI

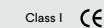

120 - 277V
 LED Integrated
 Dimmable 0-10V & TRIAC



FINISHES

WOOD SHELL

21 Natural Cherry

ACRYLIC SHELL

Black

White

WOOD VENEER SPIRALS WITH WOOD SHELL

21 Natural Cherry

WOOD VENEER SPIRALS WITH ACRYLIC SHELL

- | | |
|-------------------|--------------|
| 20 Ivory White | 26 Red |
| 21 Natural Cherry | 28 Blue |
| 22 Natural Beech | 29 Grey |
| 24 Yellow | 30 Turquoise |
| 25 Orange | 33 Pale Rose |

AWARDS

HD Las Vegas. Product Design Competition. USA

Stitches

Bamako
Tombuctú

Designed by:
Burojet

Created by Egbert-Jan Lam of Netherlands-based Burojet Design Studio, Stitches is a family of four well-hemmed pendants: Tombuctú and Bamako. Each light is named after a city or town in Mali, West Africa. Mali has a long history as a producer of embroidery, its many skilled artisans—found throughout Tombuctú and Bamako—adept at needlework.

The Stitches pendants impart an appealing bohemian air, their warm wood veneer panels embroidered with peeping threads of light. Crafted with passion and precision, Tombuctú and Bamako hint at the simple beauty found in Malian embroidery.

- **STITCHES BAMAKO - SUSPENSION**
20 Ivory White Wood Veneer.
"Le Meridien" Hotel. Tarragona, Spain.





● **STITCHES TOMBUCTÚ - SUSPENSION**
20 Ivory White Wood Veneer. "Palau de Casavells". Girona, Spain.

STITCHES

SUSPENSION

BUROJET

BAMAKO

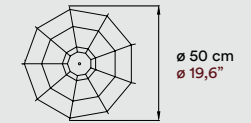
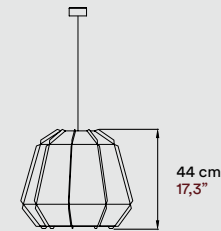

TOMBUCTÚ

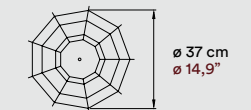
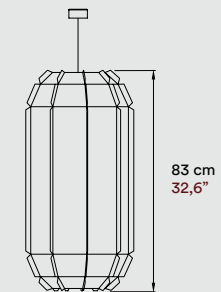

MATERIALS & COMPONENTS

Wood Veneer Shade

Metal Canopy

Steel Cable
8 ft drop. Only for USA & Canada

Electrical Cable
2 m drop 8 ft drop

LIGHT SOURCE

220 - 250V
Bulb E27









Class I CE

120 - 277V
Bulb E26 or GU24

cULus

FINISHES

WOOD VENEER

- | | |
|--|--|
|  20 Ivory White |  29 Grey |
|  24 Yellow |  30 Turquoise |
|  25 Orange |  31 Chocolate |
|  26 Red |  33 Pale Rose |
|  28 Blue | |

AWARDS



Chicago



Germany

S

W

R

Swirl

Small
Large

Designed by:
Ray Power

Swirl excites the eye with its eddying and whirling folds, their twisting twirl a sensuous feat. Designed by Ray Power, Swirl is an accomplished pendant, its form thoughtfully considered and sculptured. Power's designs are typically based on geometry and his predilection for creating three-dimensional forms from flat materials (wood veneer). Swirl is no exception, its precise contours brought to life in stereo.

With a soulful character and presence, the Swirl lamp will vibe well with any interior. When a light is striking from every angle, one might expect more than a hint of conceit. And yet Swirl is wholly modest, its beauty inspiring and uplifting.

The Swirl pendant was accorded a Special Mention by the German Design Council.

● SWIRL - LARGE SUSPENSION

20 Ivory White Wood Veneer. "Palau de Casavells". Girona, Spain.

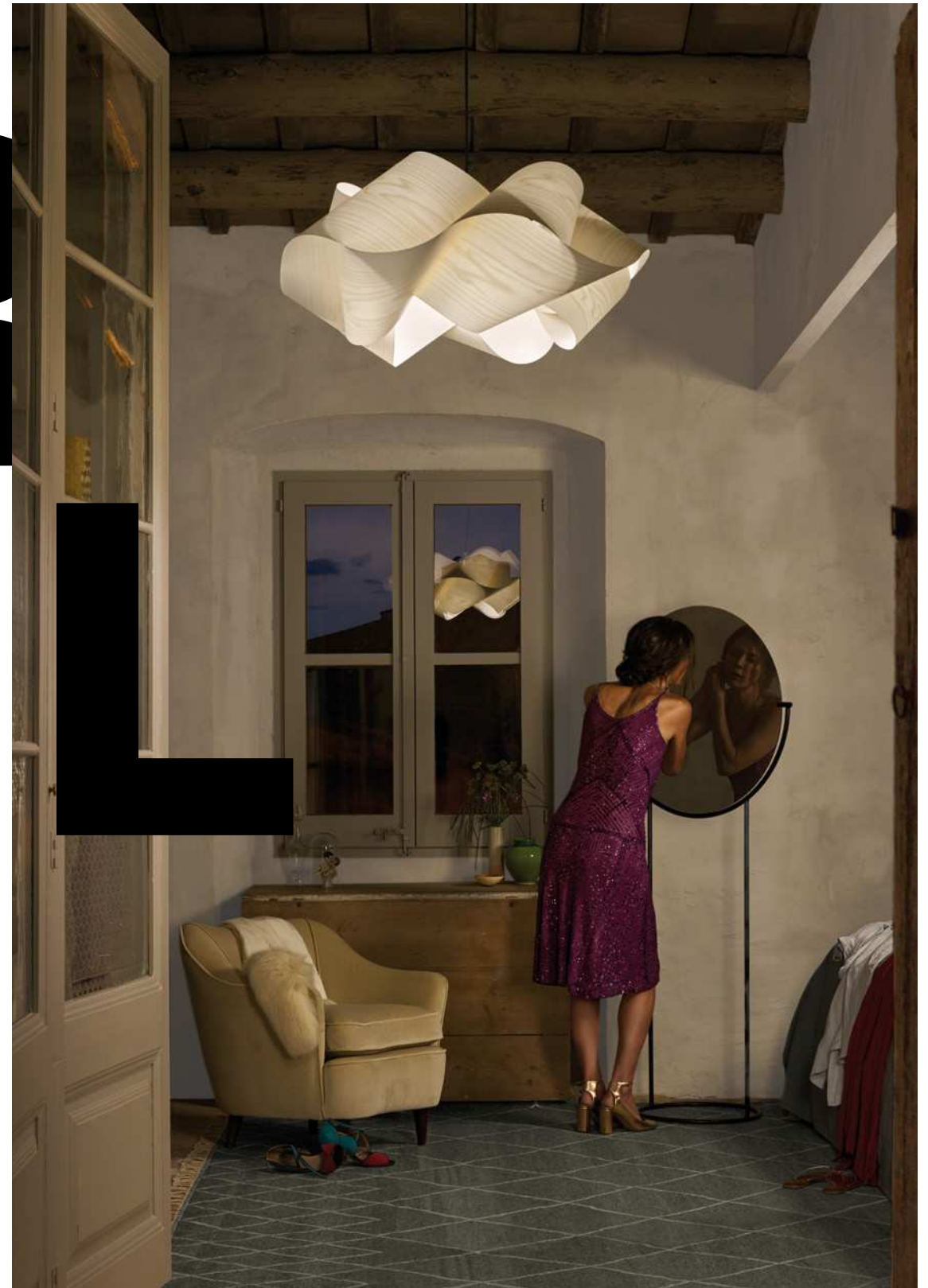

- **SWIRL - SMALL SUSPENSION**
26 Red Wood Veneer.
"Food and Fun". Valencia, Spain.

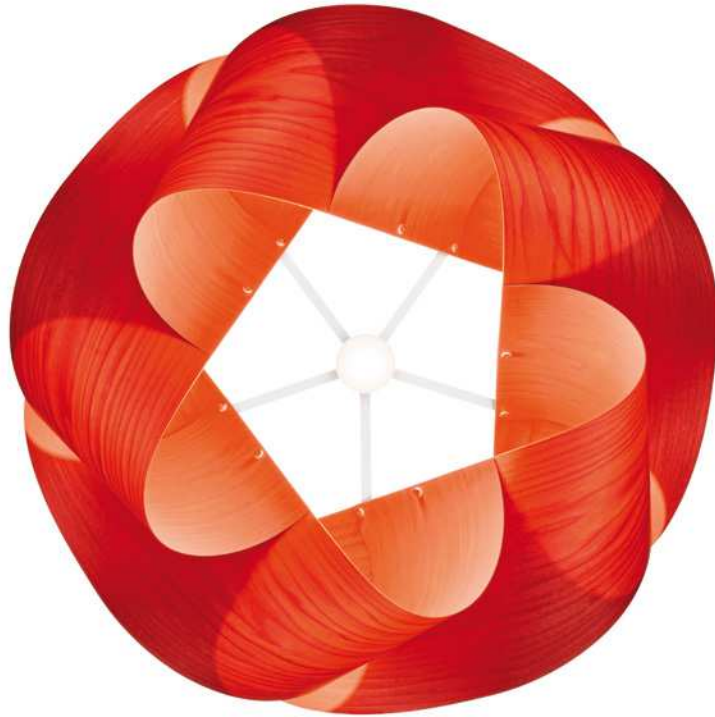

SWIRL

SUSPENSION

RAY POWER

SMALL

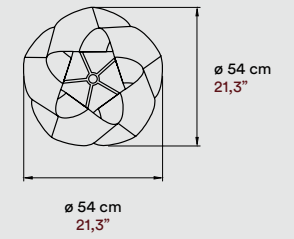
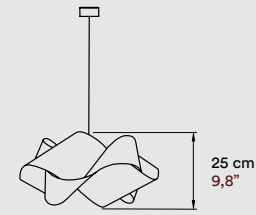

LARGE

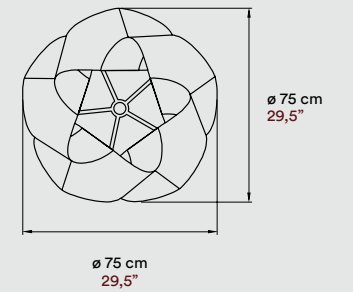
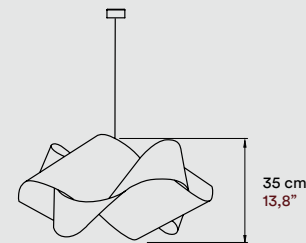

MATERIALS & COMPONENTS

Wood Veneer Shade

Metal Tripod & Canopy

Electrical Cable
2 m drop 8 ft drop

LIGHT SOURCE

220 - 250V Class I CE
Bulb E27

120 - 277V UL US
Bulb E26 or GU24

FINISHES

WOOD VENEER

- | | |
|---------------------|----------------|
| ● 20 Ivory White | ● 28 Blue |
| ● 21 Natural Cherry | ● 29 Grey |
| ● 22 Natural Beech | ● 30 Turquoise |
| ● 24 Yellow | ● 31 Chocolate |
| ● 25 Orange | ● 33 Pale Rose |
| ● 26 Red | |

AWARDS



Chicago



Germany



Totem

Totem is a veritable feast for the senses, a light whose proportions enliven a space with dramatic effect. Envisaged by designers Mariví Calvo and Burkhard Dämmer, Totem evolved from the clever amalgamation of Dämmer's Pod and Poppy pendants.

A sublime lighting structure, Totem has the emblematic air of a sacred object, a light whose shape and spirit are reflected in cultures worldwide. Available in three stacked variations, the Totem pendant diffuses warm light through the gaps in its wood veneer strips. As a physical entity, Totem's presence is impressive. Just as important, its spiritual quality is entirely unreserved.

- **TOTEM - SMALL & MEDIUM SUSPENSION**
20 Ivory White & 30 Turquoise Wood Veneer.
"Palau de Casavells". Girona, Spain.

Totem 3
Totem 4

Designed by:
Burkhard Dämmer

T
O
T
E

M



TOTEM

SUSPENSION

B. DÄMMER & MARIVÍ CALVO

SMALL - TOTEM 3

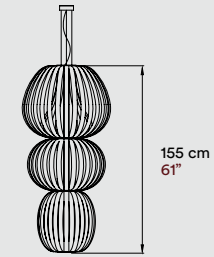

MEDIUM - TOTEM 4

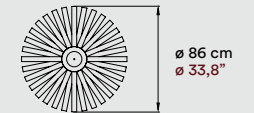
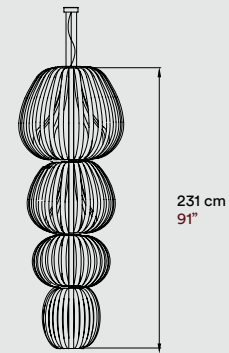

MATERIALS & COMPONENTS

3 or 4 Wood Veneer Shades

Metal Canopy

3 Steel Cables
2 m drop 8 ft drop

Electrical Cable
2 m drop 8 ft drop

LIGHT SOURCE

120 - 277V
LED Integrated
Dimmable 0-10V or Bluetooth

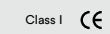

120 - 277V
LED Integrated
Dimmable 0-10V & TRIAC



FINISHES

WOOD VENEER

- | | |
|---|--|
|  20 Ivory White |  28 Blue |
|  21 Natural Cherry |  29 Grey |
|  22 Natural Beech |  30 Turquoise |
|  24 Yellow |  31 Chocolate |
|  25 Orange |  33 Pale Rose |
|  26 Red | |

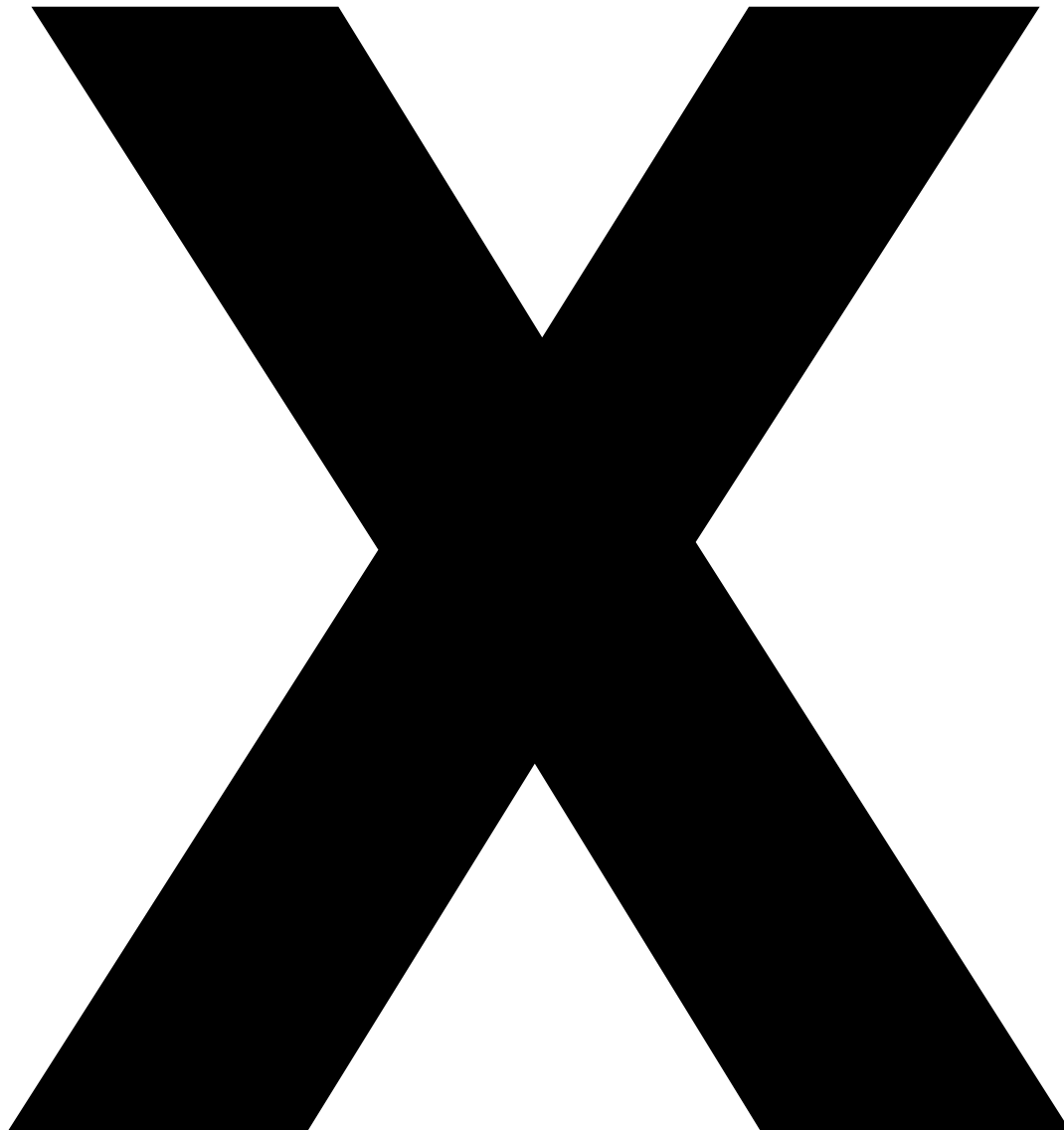

X-Club

Suspension
Wall
Ceiling

Hit the spot with the X-Club light designed by Burkhard Dämmer. With its curvy form, the X-Club emanates light with a sensual quality, akin to a three-dimensional kiss.

A wall, ceiling or suspension light, the X-Club confidently marks the spot wherever it is placed. Suited to numerous environments and contexts, from residential to retail, it is an especially impactful design when placed in clusters or rows. Light from the X-Club is both ambient and direct, with its wood veneer striking a prepossessing pose when illuminated.

- **X-CLUB - SUSPENSION**
24 Yellow & 26 Red Wood Veneer. Pharmacy, Switzerland.

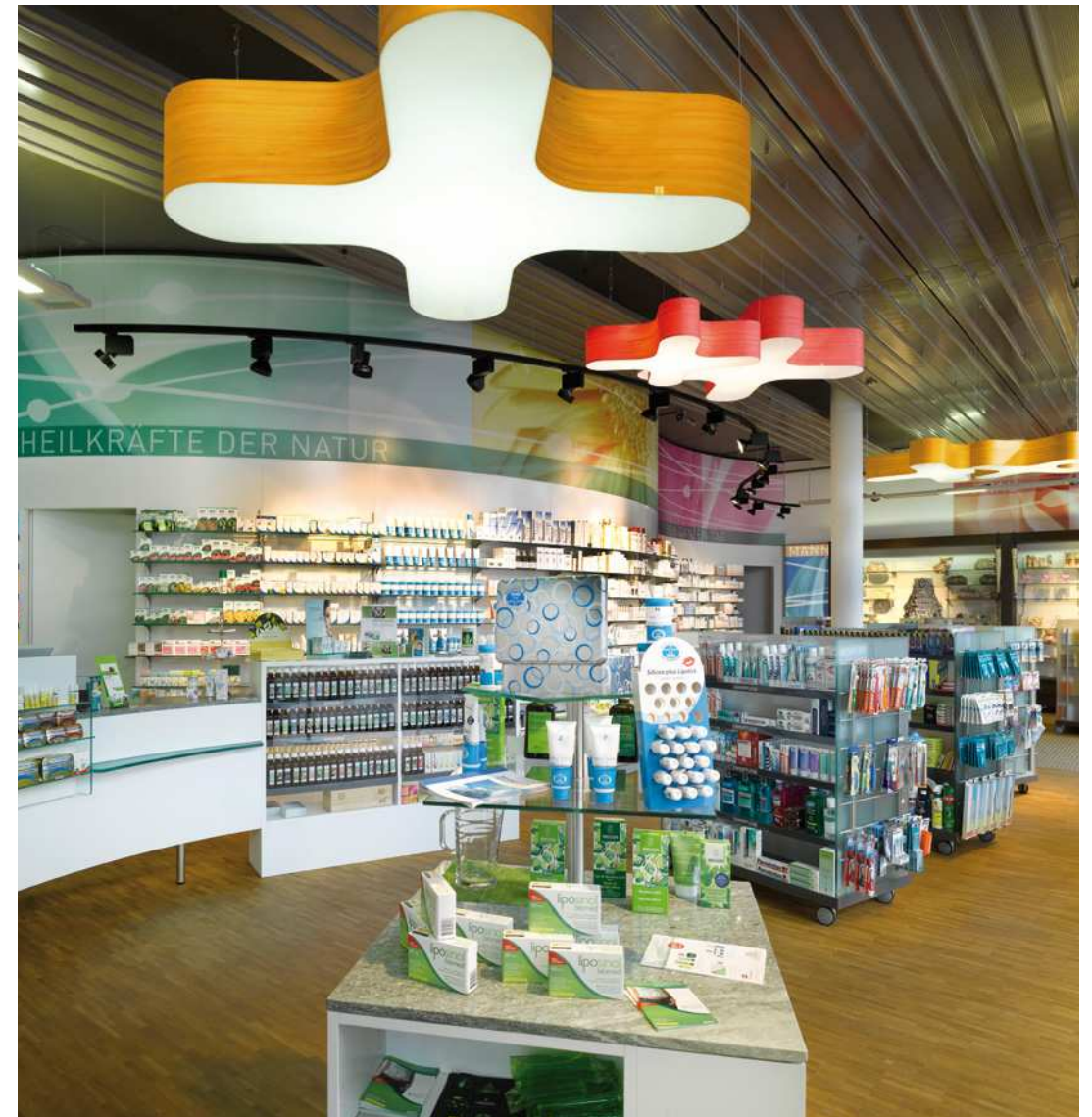

CLUB

Designed by:
Burkhard Dämmer

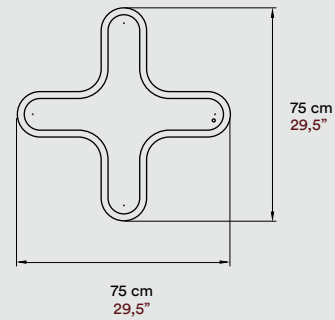
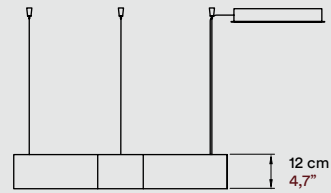

MATERIALS & COMPONENTS

Wood Veneer Shade

Top & Bottom Acrylic Diffuser

Metal Canopy

4 Steel Cables

2 m drop 8 ft drop

Electrical Cable

2 m drop 8 ft drop

LIGHT SOURCE

120 - 277V
LED Integrated
Dimmable 0-10V, Bluetooth or DALI

Class I

120 - 277V
LED Integrated
Dimmable 0-10V & TRIAC



FINISHES

WOOD VENEER

20 Ivory White	28 Blue
21 Natural Cherry	29 Grey
22 Natural Beech	30 Turquoise
24 Yellow	31 Chocolate
25 Orange	33 Pale Rose
26 Red	

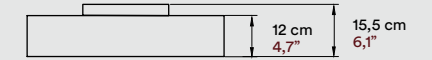
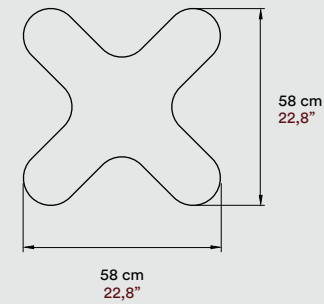

MATERIALS & COMPONENTS

Wood Veneer Shade

Frontal Acrylic Diffuser

Metal Back plate

LIGHT SOURCE

120 - 277V
LED Integrated
Dimmable 0-10V, Bluetooth or DALI

Class I

120 - 277V
LED Integrated
Dimmable 0-10V & TRIAC



FINISHES

WOOD VENEER

20 Ivory White	28 Blue
21 Natural Cherry	29 Grey
22 Natural Beech	30 Turquoise
24 Yellow	31 Chocolate
25 Orange	33 Pale Rose
26 Red	

LIFE
SIZE

BIG BIRD

Big Bird

New
Lamp

Designed by:
Isidro Ferrer & LZF Lab

As a new member of LZF's Life-Size family, Big Bird joins the happy adventures of Smelly Fant, Fish and Koi. Hovering vertically with fluttering wings, Big Bird has the agile appearance of a gentle hummingbird.

Created by the illustrator and designer Isidro Ferrer and built using a traditional craft technique called vareta, Big Bird is a masterly feat of wood craftsmanship. While light radiates from Big Bird's wooden plumage, a glass globe hangs from its beak, like a ball of glowing nectar.

With Big Bird, LZF is once again dreaming big, re-engineering the concept of what a lamp can be, in both shape and scale.

• BIG BIRD - SUSPENSION | 20 Ivory White Wood Veneer.

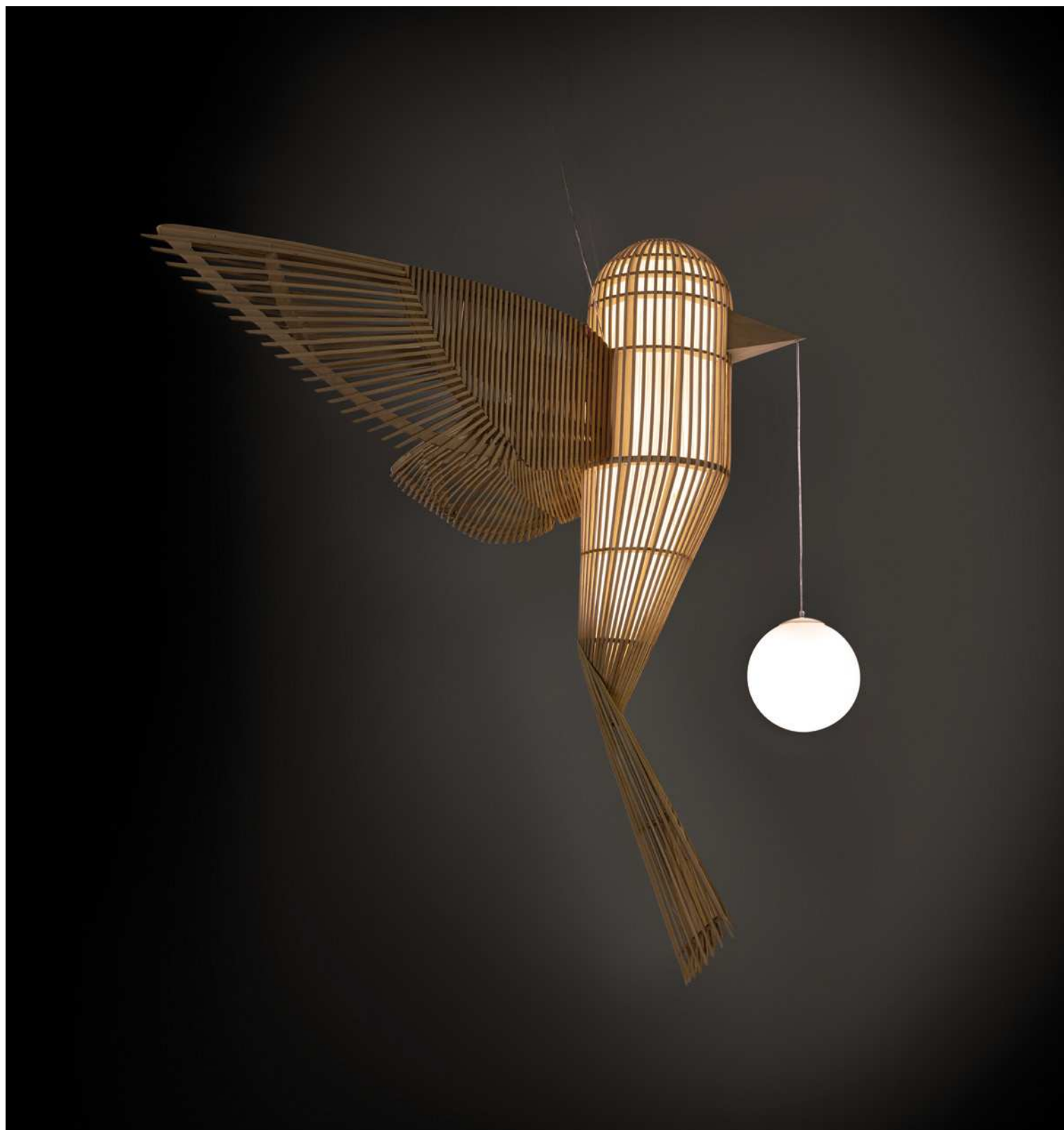



• **BIG BIRD - SUSPENSION** | 20 Ivory White Wood Veneer.

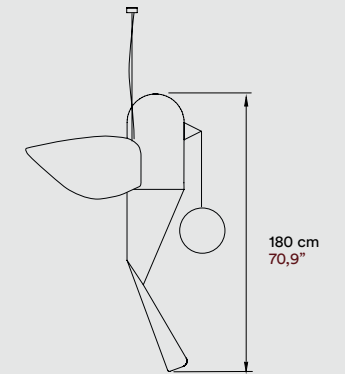
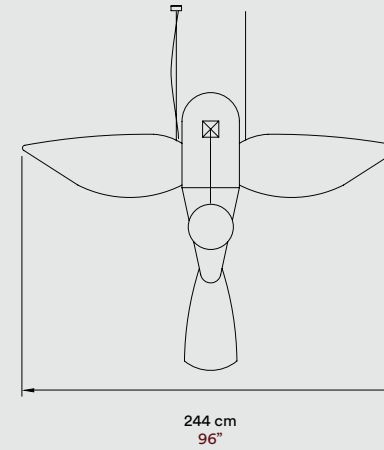

MATERIALS & COMPONENTS

Oak & Birch Wood

Wood Veneer Diffuser

Frosted Glass Ball

Metal Canopy

2 Steel Cables
5 m drop 16,5 ft drop

Electrical Cable
5 m drop 16,5 ft drop

FINISHES

WOOD VENEER

● 20 Ivory White

LIGHT SOURCE

120 - 277V
LED Integrated
Dimmable 0-10V, Bluetooth or DALI &
Bulb E27

Class I

120 - 277V
LED Integrated Dimmable &
Bulb E26 or GU24

FISH

The Walking Fish

Fish is modelled on one of the original pieces by Isidro Ferrer, a friendly fish with legs which has become one of the first large-scale light sculptures within the Funny Farm project. The carefully studied layout produces a captivating effect.

Designed by:
Isidro Ferrer & LZF Lab

- THE WALKING FISH - FLOOR
20 Ivory White Wood Veneer. "Palau de Casavells". Girona, Spain.

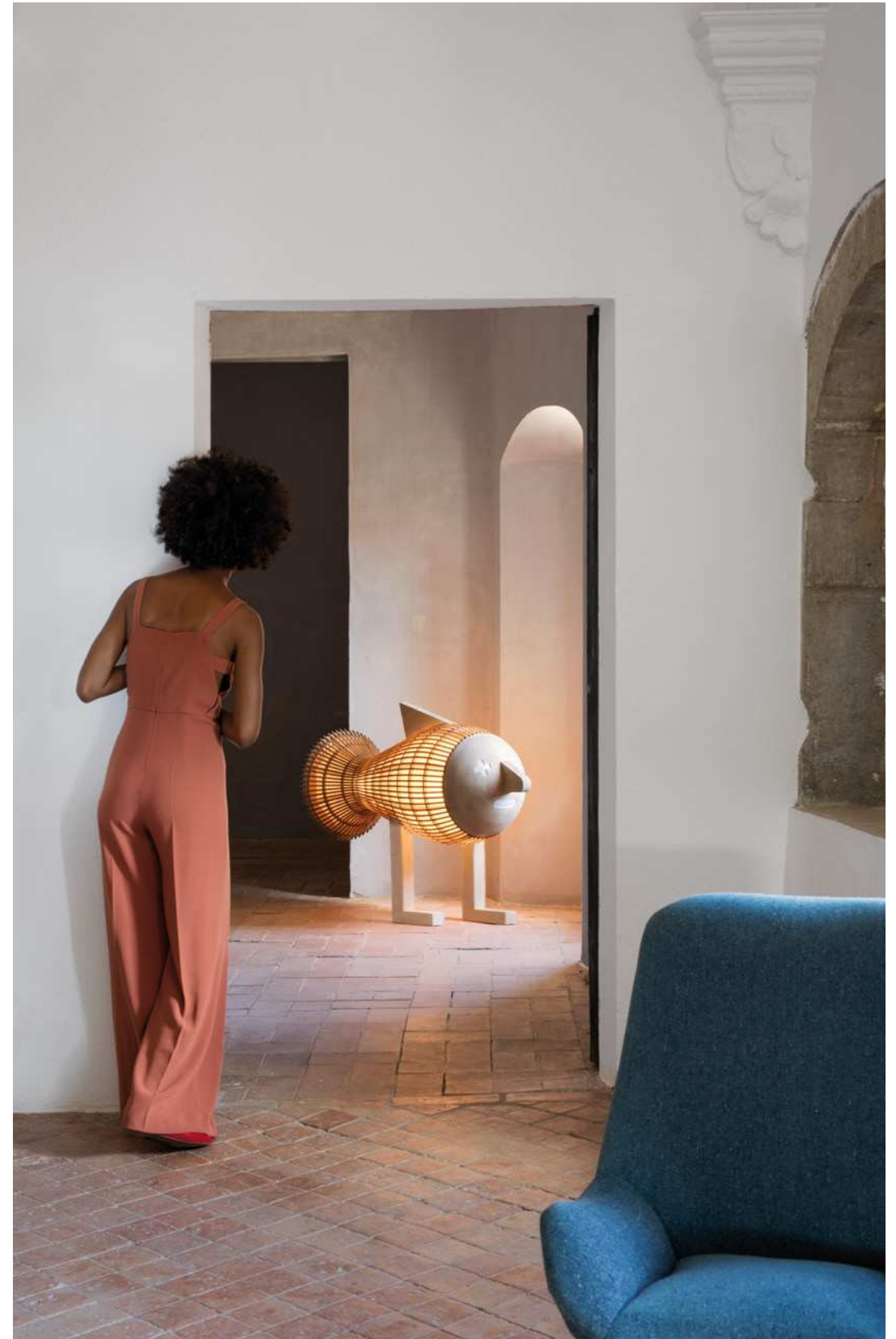



• **THE WALKING FISH**
20 Ivory White Wood Veneer.

THE WALKING FISH

LIFE SIZE - FLOOR

ISIDRO FERRER

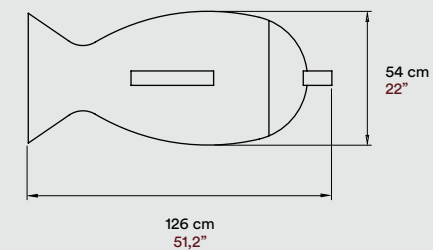
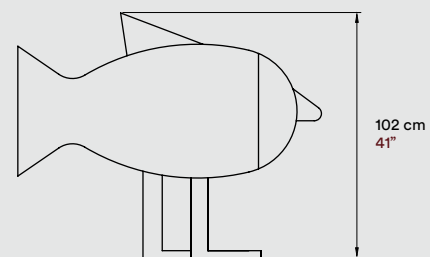

MATERIALS & COMPONENTS

Oak & Birch Wood

Wood Veneer Diffuser

Electrical Cable with Dimming Switch
200 cm 78,7"

LIGHT SOURCE

LED Integrated

Class II  

LED Integrated

FINISHES

WOOD VENEER

 20 Ivory White

SMELLY FANT

Smelly Fant

Designed by:
Isidro Ferrer & LZF Lab

Smelly Fant is the other Funny Farm animal we chose to convert into a light sculpture. Like all elephants, it has big ears, a trunk, even its own legs, and a body standing more than a meter and a half tall. To turn Isidro Ferrer's vision into a large-scale lamp, LZF has again drawn on the experience of the craftsman Manolo Martin.

Just as he did with Fish, Manolo used the "vareta" technique to shape the three spheres which constitute the body and the head of Elephant. Its luminous heart, at the centre of the sculpture, is diffused through a natural wood veneer internal lining.

- **SMELLY FANT - FLOOR**
20 Ivory White Wood Veneer.
"Palau de Casavells". Girona, Spain.





• SMELLY FANT - FLOOR | LZF "Dreams Book".

SMELLY FANT

LIFE SIZE - FLOOR

ISIDRO FERRER

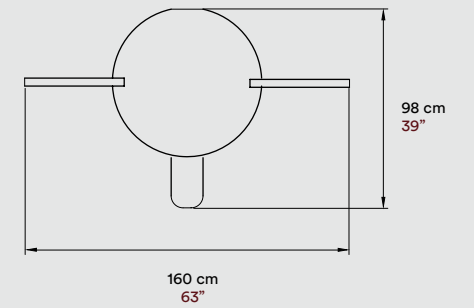
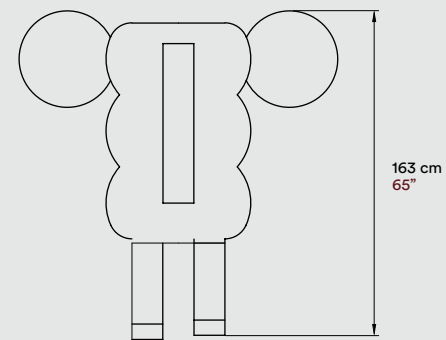

MATERIALS & COMPONENTS

Oak & Birch Wood



Wood Veneer Diffuser

Electrical Cable with Dimming Switch
200 cm 78,7"

LIGHT SOURCE

LED Integrated

LED Integrated

Class II  

FINISHES

WOOD VENEER

 20 Ivory White

AWARDS



Chicago

KOI

Koi

Designed by:
Inocuo The sign & LZF Lab

Part pendant, part sculpture, Koi is a dramatic and decorative light that appears as a surreal wood creature. Koi has an ethereal beauty: engendering a considerable sense of wonderment, its animated form captivates the eye. Cutting an imposing figure, it offers the perfect lighting climax.



• KOI - SUSPENSION | LZF "Dreams Book".



KOI

LIFE SIZE - SUSPENSION

ISIDRO FERRER

SMALL - KOGOI

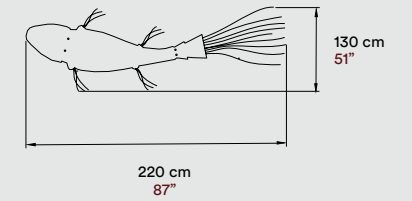
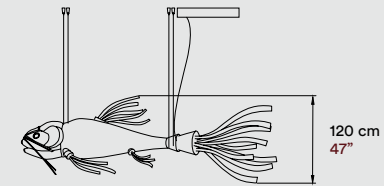

LARGE - KOI

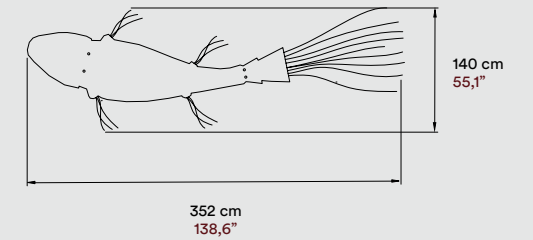
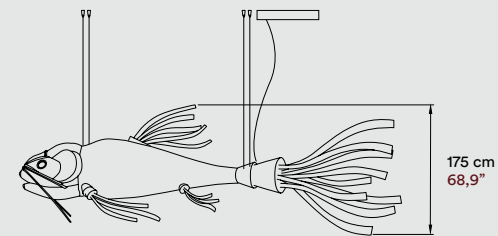

MATERIALS & COMPONENTS

Oak & Birch Wood

Wood Veneer Diffuser

Metal Canopy

4 Steel Cables
5 m drop 16,5 ft drop

Electrical Cable
5 m drop 16,5 ft drop

FINISHES

WOOD VENEER

- 20 Ivory White
- 22 Natural Beech

LIGHT SOURCE

120 - 277V
LED Integrated
Dimmable 0-10V, Bluetooth or DALI

Class I

AWARDS



Chicago

120 - 277V
LED Integrated
Dimmable 0-10V



• KOGOI - SUSPENSION | 20 Ivory White Wood Veneer.

FINISHES

NATURAL TIMBER VENEER

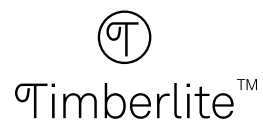

The dramatic effect of light passing through the wood veneer is the essence and hallmark of LZF. This important feature would not be possible without the application of our patented process in treating the raw natural veneer: the Timberlite® system.

This system, the result of LZF's research & development work, allows us to work with an extremely flexible, yet very resistant veneer, which can take on many shapes without breaking. In addition to all our veneers being FSC certified, thanks to the treatment, the wood used to fabricate our lamps maintains its natural qualities, adopting different nuances and hues over time.

SOURCE LIGHT TEMPERATURE

Choose your light temperature carefully, wood veneer colour can change radically depending on the colour temperature you use.

Recommended temperature LED for coloured LZF shades:

20- Ivory White (3000k-6400k)

21-Cherry, 22-Beech, 28-Blue, 29-Grey, 30-Turquoise and 31-Chocolate, (4000k)

24-Yellow, 25-Orange, 26-Red and 33 Pale Rose (2700k-4000k)

21 Natural Cherry Off



21 Natural Cherry 4000k



21 Natural Cherry 3000k



21 Natural Cherry 2700k

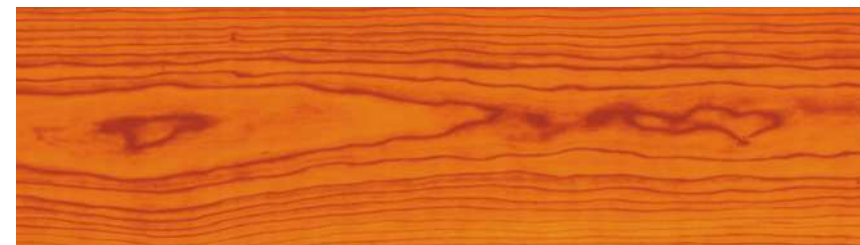

WOOD SHADE FINISHES

20.
Ivory White
Off



20.
Ivory White
On



21.
Natural
Cherry
Off



21.
Natural
Cherry
On

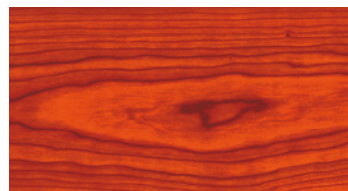

22.
Natural
Beech
Off



22.
Natural
Beech
On



24.
Yellow
Off



24.
Yellow
On



25.
Orange
Off



25.
Orange
On

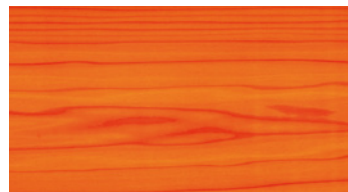

26.
Red
Off

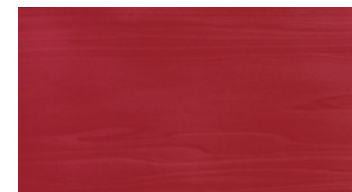

26.
Red
On



28.
Blue
Off



28.
Blue
On

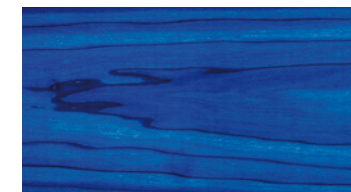

29.
Grey
Off



29.
Grey
On



30.
Turquoise
Off

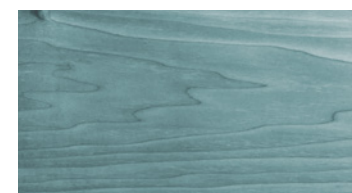

30.
Turquoise
On

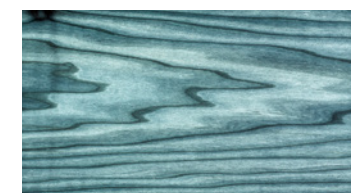

31.
Chocolate
Off



31.
Chocolate
On

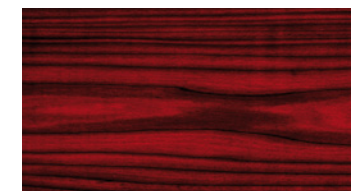

33.
Pale Rose
Off



33.
Pale Rose
On



Please only use these reproductions as a guide.
Use LZF wood swatches to see the spectacular real effect of the illuminated veneers.

METAL FINISHES



For too many years things have been simply black and white, but life is made up of many shades and we have been wanting to create a more generous array of skin colours for our lights for quite sometime. This year we have wanted to offer you the choice of not just picking your shade colour but also the colour of the metallic finish that accompanies it. Matt tones or coloured reflections in satin nickel finishes provide a whole new range of choice when selecting your lamp.

BK
Matt Black

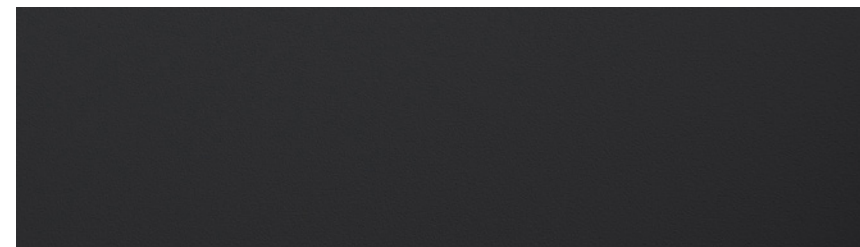

BN
Black Nickel



CO
Copper

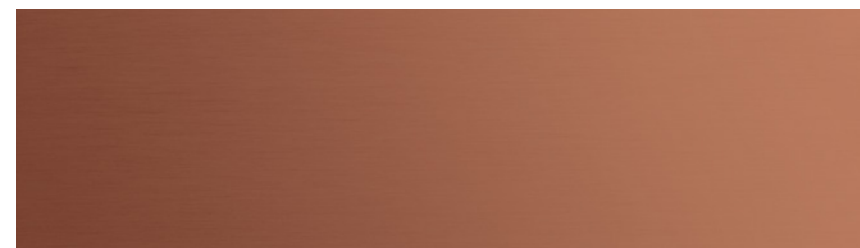

GD
Gold



IV
Matt Ivory

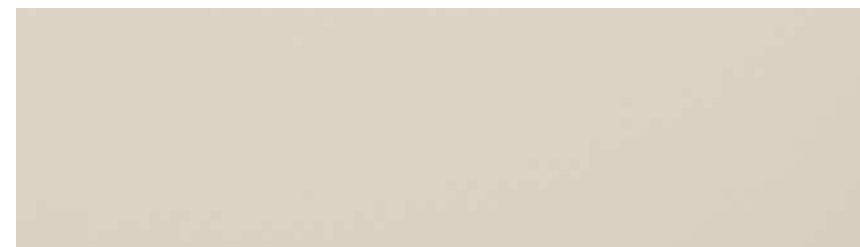

DESIGNERS

RAMÓN ESTEVE ESTUDIO

Black Note
Thesis



MUT DESIGN

Lens
Loop



OSKAR CEREZO

Carambola
Saturnia



LUIS ESLAVA STUDIO

Agatha
Paisley



JOSÉ MANUEL FERRERO estudi{H}ac

Skyline



RAY POWER

Air
Escape
Hi-Collar
Link
Lola
New Wave
Nut
Swirl



MIGUEL HERRANZ

MiniMikado
Orbit



JAVIER HERRERO STUDIO

Raindrop



MARIVÍ CALVO

Candelabro
Cosmos
Gea
Guijarro



BURKHARD DÄMMER

Cervantes
Cuad
Dandelion
I-Club
Icon
Pod & Poppy
Totem
X-Club



REMEDIOS SIMÓN

Spiro



RQR STUDIO

Domo

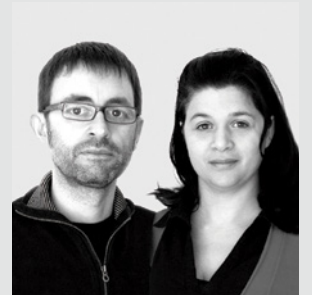

YONOH CREATIVE STUDIO

Banga
Chou
Mini Chou
Pleg

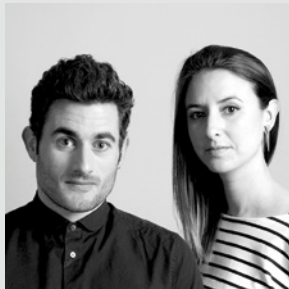

ISIDRO FERRER

Big Bird
Smelly Fant
The Walking Fish



MACALULA

Piknik



BUROJET

Stitches



CREDITS

Project Director

Mariví Calvo

Graphic Design

Lo Siento

Photo Art Direction

Mariví Calvo

Pilar Amigo

Pablo Gironés

Lzf Graphic Design

Miriam Castellano

Writer

Gerard McGuickin

Printed By

Logik Graphics, 2019

Photographers

Santiago Relanzón

Ángel Segura

Klunderbie

Jara Varela

Cualiti

Maria Mira

All our thanks to

Ramón Esteve Estudio

Nerínea

Jose e Isabel, “Casa en la Huerta”

“Bouet” Restaurant

Cosín Estudio