



lzf

WOOD touched by **LIGHT**

Since 1994



WOOD

TOUCHED BY

LIGHT

lžf

HISTORY



At LZF, we have made a conscious and deliberate choice to manufacture our lamps at home in Valencia, Spain. This is a region with an exceptional wealth of talent and expertise. By working locally, we enjoy much greater control and flexibility over the design and creation of every LZF lamp.

It is now more than twenty-five years since the inception of LZF as a lighting brand. Today, we are a business that thrives on time-honoured craft and manufacturing techniques, complemented by modern innovation and technology. We are thrilled to work with an eclectic roster of accomplished designers and diligent craftspeople. As a collective result, LZF has received more than thirty-five national and international awards, most notably Spain's Premios Nacionales de Innovación y de Diseño 2020 (the National Innovation and Design Award 2020) and the Premio Nacional de Artesanía in 2011 (the Spanish National Craftsmanship Award).

As a family business, LZF is always on the side of the client and working tirelessly to meet their needs. We endeavour to provide our clients with a warm, friendly, and professional level of service. As artisans, artists, designers, innovators, and technicians, we put our heart and soul into our work. We stand behind everything we do.

At LZF, we approach every aspect of our business with responsibility and accountability. We believe in the principle of less but better. We are not guided by trends: our collection is permanent and our handmade lamps are built to last. We know that any pursuit of keeping costs low serves no honest or useful purpose. In a world of fast design, mass consumption, and harmful waste, we believe in the absolute importance of manufacturing locally, in championing tradition, in a circular economy, and in promoting sustainability.

Spain is a country that is proudly dependent on its local talent and manufacturing: this is part of our nature. With increasing globalisation, we must work to regenerate the industrial fabric on which many generations of tradition have been built. LZF recognises the continual need to support our local business endeavours, and we do so with complete commitment and a willingness to collaborate.

LZF, proudly handmade in Spain.

NATURAL WOOD MEANS NATURAL LIGHT

Timberlite™



The mark of
responsible forestry

Wood is a noble material and has been part of our DNA since our beginnings. All LZF lamps are handmade from FSC natural wood veneer, ensuring their origin from controlled forests and guaranteeing our sustainability and environmental commitment. LZF lamps' wood veneers are treated with a technique patented by LZF, called Timberlite®, that allows this fragile material to become flexible and resistant without the need of any chemical processes. Knots and other elements of wood are a natural occurrence and form part of the feel and design of the material. As a living material our veneers will age with time, changing as you change, accompanying you with their richness during a whole lifetime.

ON



OFF



CONTENTS

INDEX 10

LATEST COLLECTION 14

| | |
|---------|----|
| Dune | 16 |
| Estela | 20 |
| Eris | 24 |
| Tomo | 30 |
| Lens | 34 |
| Oh!Line | 38 |
| I-Line | 42 |
| Maruja | 46 |
| Suns | 50 |

THE COLLECTION 54

| | |
|--------------|-----|
| Agatha | 56 |
| Air | 62 |
| Banga | 66 |
| Black Note | 70 |
| Candelabro | 84 |
| Carambola | 90 |
| Mini Chou | 94 |
| Chou | 98 |
| Cuad | 102 |
| Dandelion | 106 |
| Domo | 110 |
| Escape | 114 |
| Gea & Cosmos | 118 |
| Guijarro | 126 |
| Hi-Collar | 130 |
| I-Club | 134 |
| Lens | 142 |
| Link | 148 |
| Lola | 156 |

| | |
|-------------|-----|
| MiniMikado | 170 |
| New Wave | 176 |
| Nut | 180 |
| Orbit | 184 |
| Pleg | 188 |
| Pod & Poppy | 192 |
| Raindrop | 196 |
| Saturnia | 200 |
| Spiro | 204 |
| Stitches | 210 |
| Swirl | 214 |
| Totem | 218 |
| Thesis | 222 |
| X-Club | 230 |

LIFE SIZE 234

| | |
|------------------|-----|
| Smelly Fant | 236 |
| The Walking Fish | 240 |
| Big Bird | 244 |
| Koi & Kogoi | 252 |

NATURAL TIMBER VENEER 258

METAL FINISHES 262

DESIGNERS 264

CREDITS 267

INDEX

1



AGATHA 56
Suspension



AGATHA BALL 56
Suspension



BANGA 66
Suspension



BLACK NOTE 70
Keys / Suspension,
Floor & Wall



BLACK NOTE 70
Triplet / Suspension,
Floor & Wall



CANDELABRO 84
Suspension



CARAMBOLA 90
Suspension



CUAD 102
Suspension



DANDELION 106
Suspension



DOMO 110
Suspension



DUNE 16
Suspension



ESCAPE 114
Suspension



ERIS 24
Suspension & Table

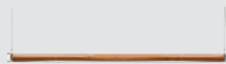

ESTELA 20
Suspension



GEA 118
Susp., Floor, Wall &
Ceiling



I-CLUB 134
Susp., Table, Wall
& Ceiling



I-LINE 42
Suspension



LINK 148
Suspension & Floor



LOLA 156
Suspension, Table & Floor



MARUJA 46
Suspension



MINIMIKADO 170
Suspension



NEW WAVE 176
Suspension



NUT 180
Suspension



OH!LINE 38
Suspension



POD & POPPY 192
Suspension



RAINDROP 196
Suspension



SATURNIA 192
Suspension



SPIRO 204
Suspension



STITCHES 210
Suspension



SUNS 50
Suspension Panel



SWIRL 214
Suspension



TOMO 30
Suspension & Table



TOTEM 218
Suspension



X-CLUB 230
Suspension & Ceiling

2

LIFE SIZE



BIG BIRD 244
Suspension



WALKING FISH 240
Floor



SMELLY FANT 236
Floor



KOI & KOGOI 252
Suspension

INDEX

3

TABLE



AIR 62
Table & Wall



CHOU 98
Table



CHOU 98
Table



ERIS 24
Suspension & Table



I-CLUB 134
Susp., Table, Wall & Ceiling



LOLA 156
Suspension, Table & Floor



LOLA LUX 156
Table



LENS 142
Table, Floor & Wall



LENS 142
Table, Floor & Wall



TOMO 30
Suspension & Table



THESIS 222
Table, Floor & Wall

4

FLOOR



BLACK NOTE 70
Triplet / Suspension,
Floor & Wall



COSMOS 118
Susp., Floor, Wall &
Ceiling



LENS 142
Table, Floor & Wall



LENS 142
Table, Floor & Wall



LINK 148
Suspension & Floor



LOLA 156
Suspension, Table & Floor

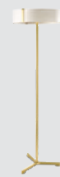

THESIS 222
Table, Floor & Wall

5

CORDLESS



MINI CHOU 94
Table

6

WALL & CEILING



AIR 62
Table & Wall



BLACK NOTE 70
Duplet / Suspension,
Floor & Wall



GEA 118
Susp., Floor, Wall &
Ceiling



LOLA 156
Suspension, Table,
Floor & Wall



GUIJARRO 126
Wall & Ceiling



GUIJARRO 126
Wall & Ceiling



GUIJARRO 126
Wall & Ceiling



HI-COLLAR 130
Wall



I-CLUB 134
Suspension, Table,
Wall & Ceiling



LENS 34
Table, Floor & Wall



LENS 34
Table, Floor & Wall



LENS 34
Table, Floor & Wall



PLEG 188
Wall



ORBIT 184
Wall



THESIS 222
Table, Floor & Wall



X-CLUB 230
Suspension & Ceiling



LATEST
COLLEC
TION

DUNE

Dune

Designed by:
Mayice Studio

Dune is a sculptural light whose shape is intriguingly amorphous. Designed by Madrid-based Mayice Studio, Dune is a single piece of hand-blown borosilicate glass, enveloping a wood veneer diffuser with a seedpod-like opening on one side. The glass is hand-blown by Eduard Garuti, an accomplished artisan. With mastery and great dexterity, the work of Mayice and Garuti is able to reveal the natural beauty found in glass and combine this to perfection with the wood.

Dune's distinctive shape is made up of two symmetrical ends, and an irregular, bulb-shaped centre. The wood veneer diffuser houses the lamp's dimmable LED light source, and downward light from the seedpod-like opening is softened by the glass. Each numbered Dune lamp is unique: the beauty found in the imperfection of hand-blown glass, with its almost wabi-sabi quality, ensures Dune is like a piece of art.



● **DUNE - SUSPENSION**

30 Turquoise & Glass. "Refugio en la Viña". Valencia, Spain. Architect: Ramón Esteve Estudio.

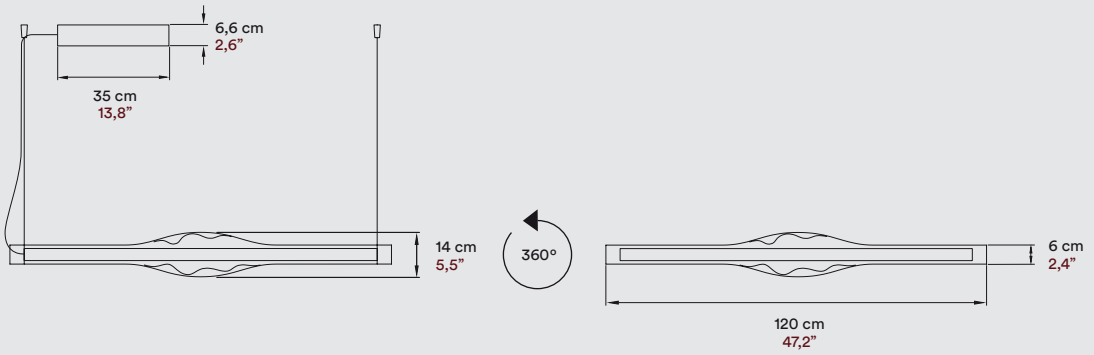

MATERIALS & COMPONENTS

Wood Veneer Shade

Hand Blown Glass: Borosilicate

Metal Canopy

Coaxial Cable

2,5 m drop 8 ft drop

2 Steel Cables

2,5 m drop 8 ft drop

LIGHT SOURCE

120 - 277V

LED Integrated

Dimmable 0-10V, Bluetooth or DALI

Class I CE

120 - 277V

LED Integrated

Dimmable 0-10V or TRIAC

cUL US

FINISHES

WOOD VENEER

- 20 Ivory White
- 30 Turquoise
- 21 Natural Cherry
- 33 Pale Rose
- 22 Natural Beech
- 34 Sea Blue

AWARDS



USA



INTERIOR DESIGN
USA



● **DUNE - SUSPENSION**
21 Natural Cherry Wood Veneer & Glass.

● **DUNE - SUSPENSION**
33 Pale Rose Wood Veneer & Glass.

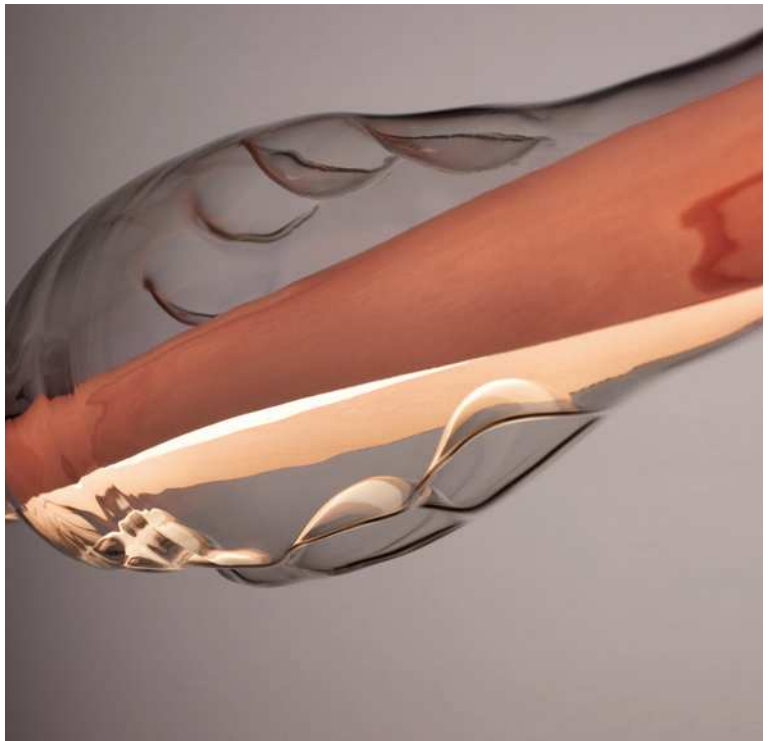

ESTELA

Designed by:
Mayice Studio

Estela

Estela is a captivating capsule of light. In Estela, Mayice Studio designed a clean, clear, single piece of borosilicate glass. Hand-blown by the accomplished artisan Eduard Garuti, the glass envelopes a cylinder-like wood veneer diffuser. The wood veneer houses a dimmable LED light source, and a straight opening on one side emits downward light that is softened by the glass.

Offering a seamless connection between both glass and wood, Estela is a radiant lamp with a celestial-like quality. It can also be used together with Dune to create alternating design solutions for board rooms, offices, and hospitality settings. Estela's natural imperfections, a characteristic of hand-blown glass, add to its warmth and elegance.

-
- **ESTELA - SUSPENSION**
20 Ivory White Wood Veneer & Glass.



ELLA

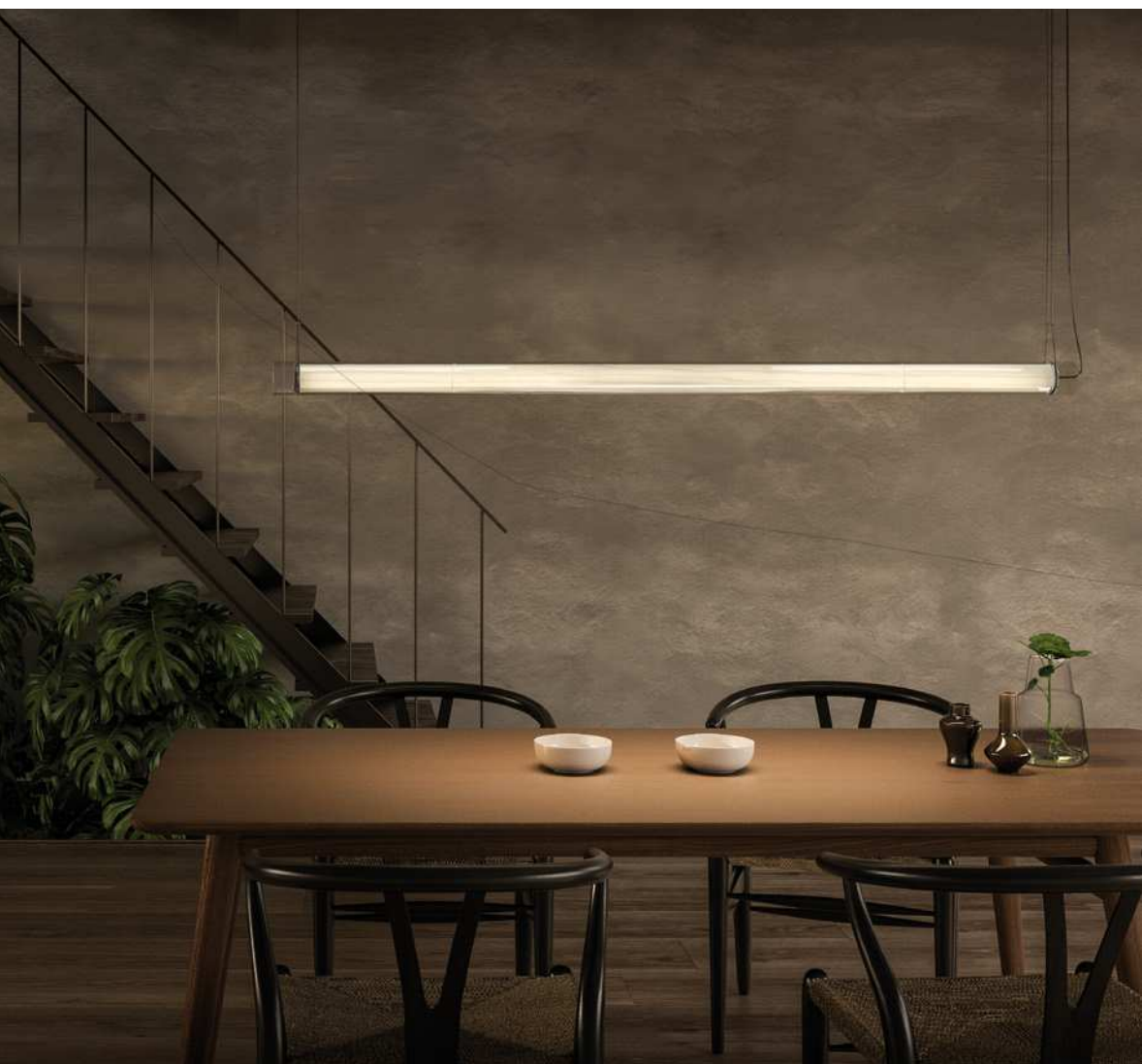

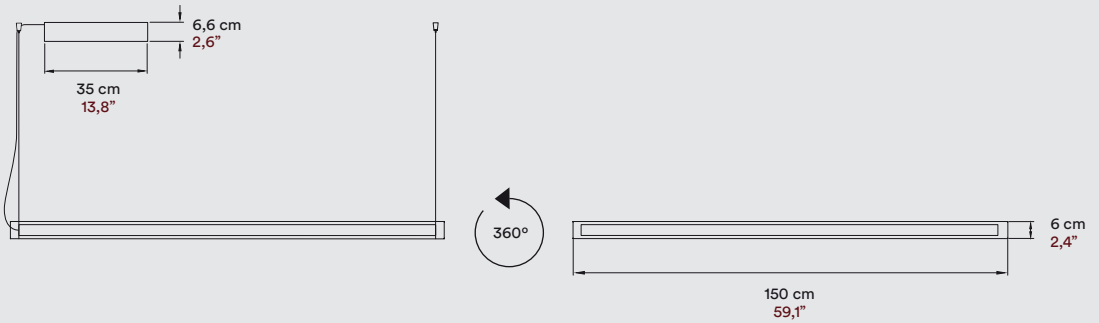

MATERIALS & COMPONENTS

Wood Veneer Shade

Hand Blown Glass: Borosilicate

Metal Canopy

Coaxial Cable

2,5 m drop 8 ft drop

2 Steel Cables

2,5 m drop 8 ft drop

FINISHES

WOOD VENEER

- 20 Ivory White
- 33 Pale Rose
- 21 Natural Cherry
- 34 Sea Blue
- 22 Natural Beech

LIGHT SOURCE

120 - 277V

LED Integrated

Dimmable 0-10V, Bluetooth or DALI

Class I

120 - 277V

LED Integrated

Dimmable 0-10V or TRIAC



● **ESTELA - SUSPENSION**
33 Pale Rose Wood Veneer & Glass.

*Second image: View from below,
reflected on the glass table.



Eris

Suspension
Table

Designed by:
Mayice Studio

Eris has an abstract and ethereal beauty, similar to the planet of the same name. Designed by Mayice Studio, Eris is made up of several components: an original borosilicate glass orb, hand-blown by Master Artisan glass-blower Eduardo Garuti, a wood veneer tube (that contains the LED light source), and a metallic base.

Available as both a table lamp and a suspension lamp, Eris is sublime. Radiant when the light is on and ornamental when off, Eris has an ethereality that captures the perfect symbiosis of Glass and wood.



-
- **ERIS - TABLE**
22 Natural Beech Wood Veneer, Glass & Metal Structure.

ERIS

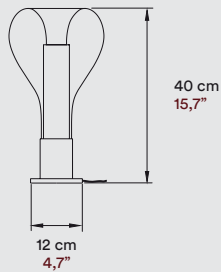

MATERIALS & COMPONENTS

Wood Veneer Shade

Hand Blown Glass: Borosilicate

Metal Base

Electrical Cable with Dimming Switch

145 cm 57"

LIGHT SOURCE

220 - 250V

Bulb GU10

Class II  





120V

Bulb GU10





FINISHES

WOOD VENEER

- | | |
|-------------------------------------------------------------------------------------------------------|------------------------------------------------------------------------------------------------------|
|  20 Ivory White |  22 Natural Beech |
|  21 Natural Cherry |  33 Pale Rose |

ESTRUCTURE

- | | |
|--------------------------------------------------------------------------------------------------|---------------------------------------------------------------------------------------------------|
|  AL-Aluminium |  BK-Matt Black |
|--------------------------------------------------------------------------------------------------|---------------------------------------------------------------------------------------------------|



● **ERIS - TABLE**
22 Natural Beech Wood Veneer, Glass & Metal Structure.

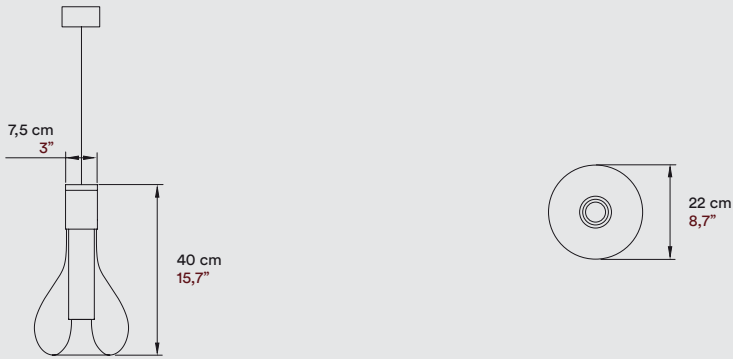

MATERIALS & COMPONENTS

Wood Veneer Shade

Hand Blown Glass: Borosilicate

Metal Structure

Metal Canopy

Electrical Cable
2,5 m drop 8 ft drop

FINISHES

WOOD VENEER

- 20 Ivory White
- 22 Natural Beech
- 21 Natural Cherry
- 33 Pale Rose

ESTRUCTURE

- AL-Aluminium
- BK-Matt Black

LIGHT SOURCE

220 - 250V Class I
Bulb GU10

120V
Bulb GU10



● **ERIS - SUSPENSION**

20 Ivory White Wood Veneer, Glass & Metal Structure.

"Refugio en la Viña". Valencia, Spain. Architect: Ramón Esteve Estudio.

Tomo

T O



• TOMO - SUSPENSION | 22 Natural Beech, 34 Sea Blue & 20 Ivory White Wood Veneer

Designed by:
MUT Design

Suspension
Table

Tomo is a lamp whose design is reminiscent of books placed side by side. This thoughtful and earnest lamp was designed by Valencia-based Mut Design Studio.

Tomo is presented as a chain of wood veneer oblongs, with varying heights and widths. The

resulting shapes are both graphic and geometric in form. Tomo is designed as a table lamp and a suspension lamp, with dimmable LED, and a light-filtering diffuser. As a table lamp, Tomo's arrangement is evocative of book spines; as a pendant, Tomo appears like an illuminated row of hanging volumes.



• **TOMO - TABLE**

20 Ivory White Wood Veneer.

"Goded" Housing, Valencia, Spain. Project: Raw Arquitectura. Photography: Cualiti Photo Studio. Furniture: Annud.

TALL

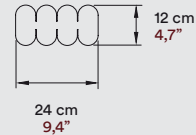
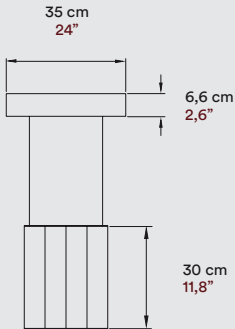

LONG

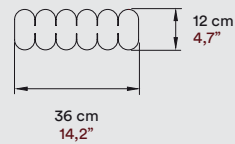
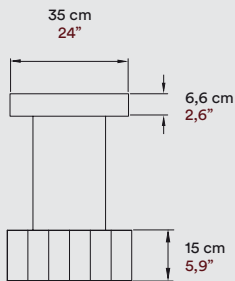

MATERIALS & COMPONENTS

Wood Veneer Shade

Bottom Acrylic Diffuser

Metal Structure







Metal Canopy

2 Electrified Steel Cables

2,5 m drop 8 ft drop

FINISHES

WOOD VENEER

- | | | | |
|-------------------------------------------------------------------------------------|-------------------|-------------------------------------------------------------------------------------|--------------|
|  | 20 Ivory White |  | 24 Yellow |
|  | 21 Natural Cherry |  | 33 Pale Rose |
|  | 22 Natural Beech |  | 34 Sea Blue |

LIGHT SOURCE

120 - 277V

LED Integrated

Dimmable 0-10V or Bluetooth

Class I 

120 - 277V

LED Integrated

Dimmable 0-10V & TRIAC

 PENDING

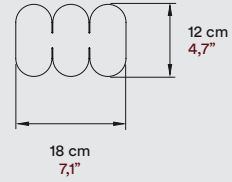
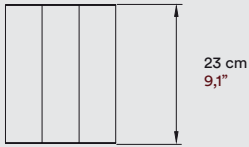

MATERIALS & COMPONENTS

Wood Veneer Shade

Upper Acrylic Diffuser

Metal Base

Electrical Cable with Dimming Switch

145 cm 57"

Plug-in Driver

LIGHT SOURCE

LED Integrated Dimmable







Class II  

LED Integrated Dimmable

 PENDING

FINISHES

WOOD VENEER

- | | | | |
|-------------------------------------------------------------------------------------|-------------------|-------------------------------------------------------------------------------------|--------------|
|  | 20 Ivory White |  | 24 Yellow |
|  | 21 Natural Cherry |  | 33 Pale Rose |
|  | 22 Natural Beech |  | 34 Sea Blue |

LENS

Lens

Wall
Floor
Table

Designed by:
Mut Design



• LENS

20 Ivory White Wood Veneer, Gold Metal Structure & Mirror.

The new wall version of LZP's Lens lamp incorporates an eye-catching central mirror. Designed by Mut Design Studio, Lens is a lamp created with flowing lines and no hard edges. The Lens wall lamp is available in three shapes: circle, oval, and super oval.

Made up of wood veneer, a metal ring and back plate, the new mirror fitting is an alluring addition to the Lens wall lamp. The lamp's dimmable LED provides a soft, halo-like warmth. A light that works as a single fixture or in a group, the Lens wall lamp adds a reflective depth to any space.

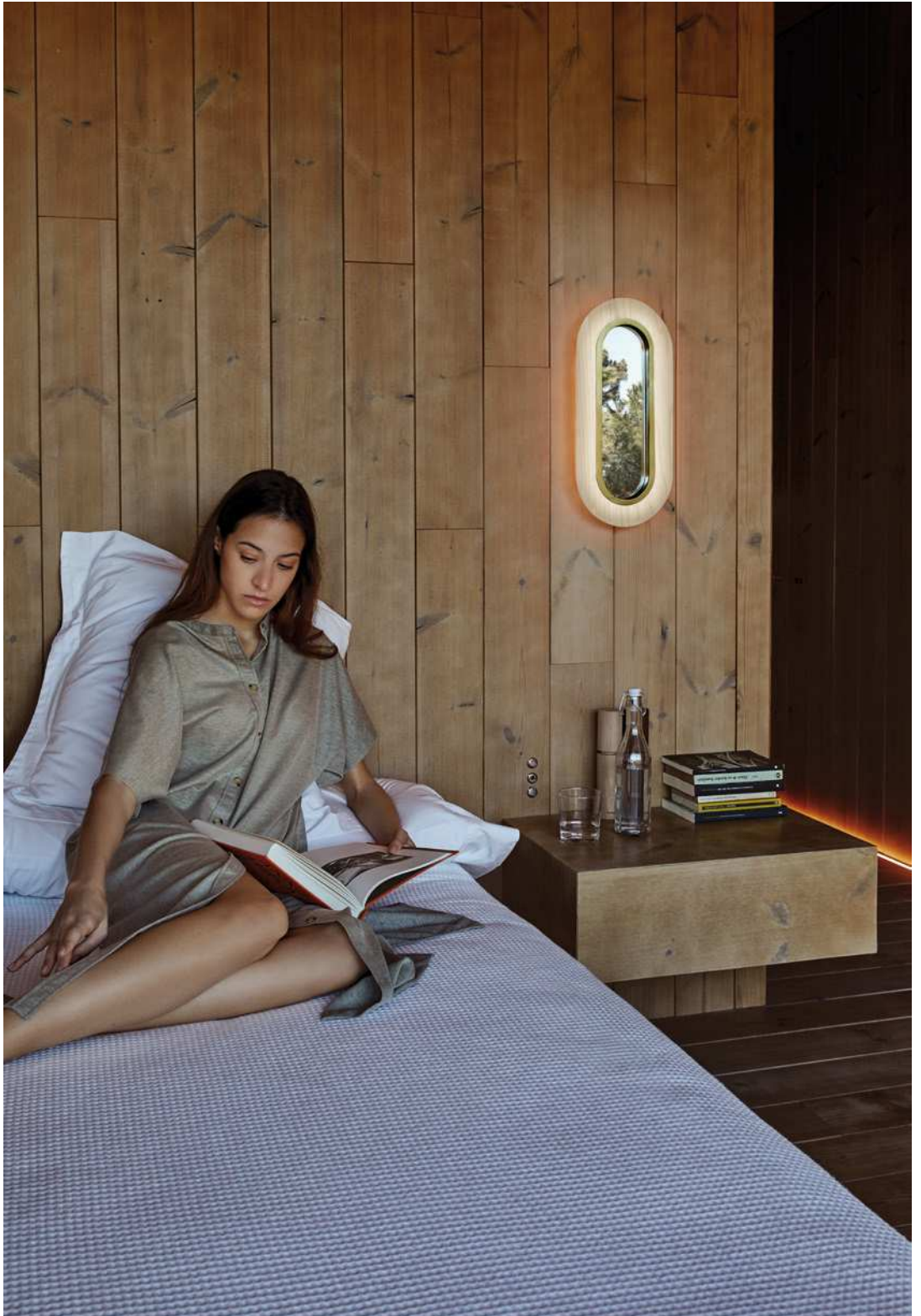

● LENS - WALL OVAL

20 Ivory White Wood Veneer, Gold Metal Structure & Mirror.

"Casa en la Huerta". Valencia, Spain. Architect: Ramón Esteve Estudio.

CIRCULAR

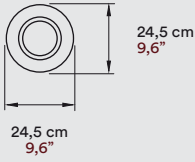

OVAL

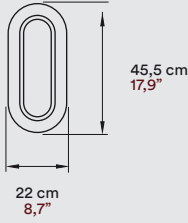

SUPEROVAL

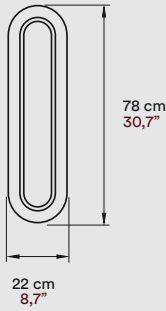

MATERIALS & COMPONENTS

Wood Veneer Shade

Central Mirror

Metal Ring

LIGHT SOURCE

120-277V

LED Integrated
Dimmable 0-10V

Class I

120 - 277V

LED Integrated
Dimmable 0-10V & TRIAC



ADA Compliant

FINISHES

WOOD VENEER

- 20 Ivory White
- 28 Blue
- 21 Natural Cherry
- 29 Grey
- 22 Natural Beech
- 33 Pale Rose

METAL

- IV-Matt Ivory
- NI-Matt Nickel
- BK-Matt Black
- GD-Gold



● **LENS - WALL CIRCULAR**

20 Ivory White Wood Veneer, Gold Metal & Mirror. Photo: 4000k.
"Casa en la Huerta". Valencia, Spain. Architect: Ramón Esteve Estudio.

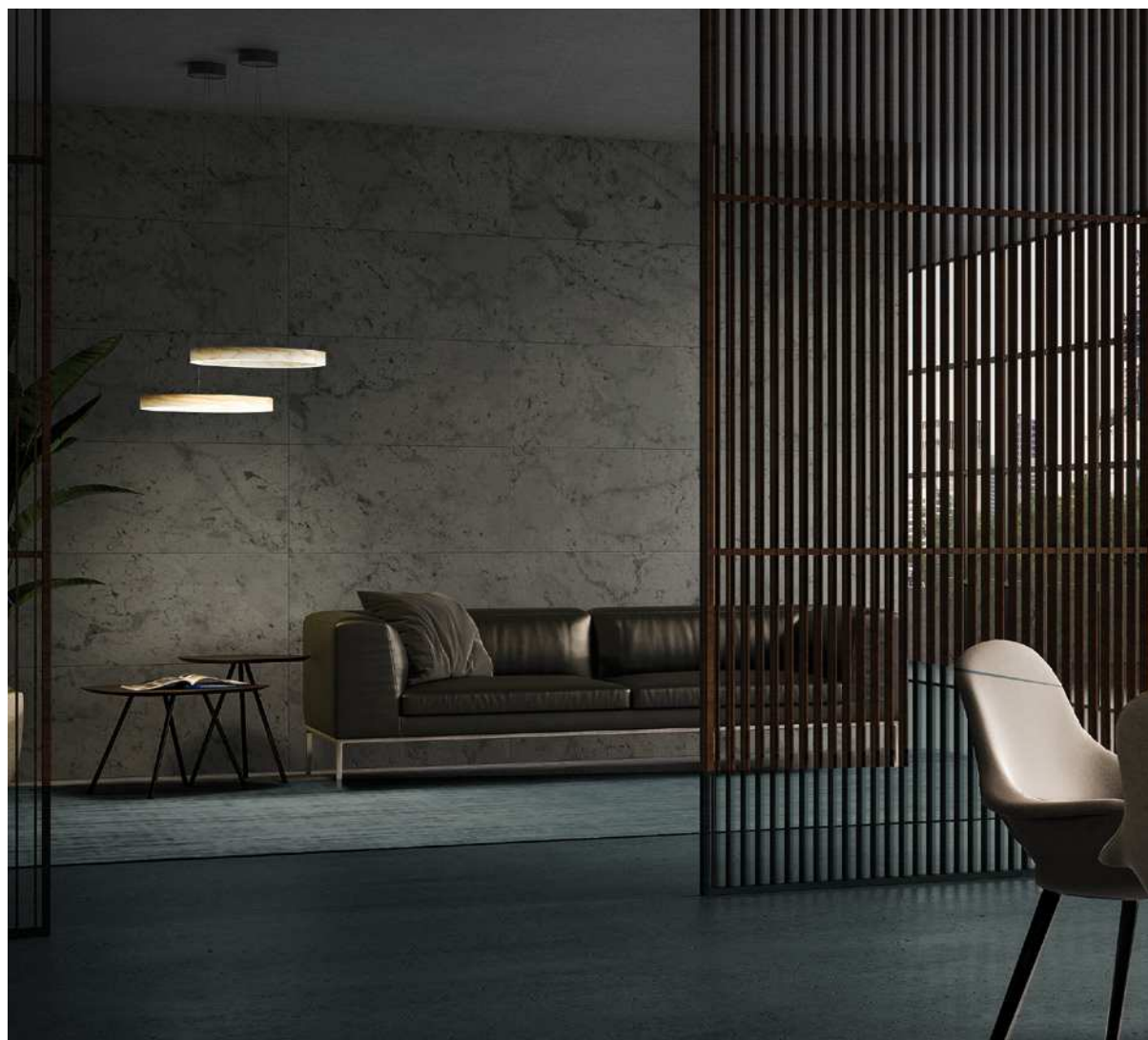

OH!



Oh!Line

Medium
Large

Designed by:
Burkhard Dämmer
& Mariví Calvo

Imagine sitting beneath a halo of light. This is the effect created by Oh!Line, a svelte circle of light. Designed by Mariví Calvo & Burkhard Dämmer, Oh!Line is available in two sizes: medium and large suspension.

With its slim form, wood veneer, dimmable LED, and light-filtering diffuser, Oh!Line radiates warmth and elegance. Light from the ring-shaped Oh!Line provides a relaxed ambience and a focused glow

-
- OH!LINE - SUSPENSION
20 Ivory White Wood Veneer.

MEDIUM

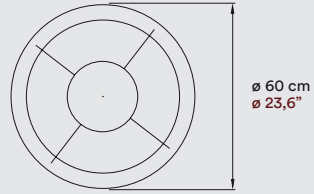
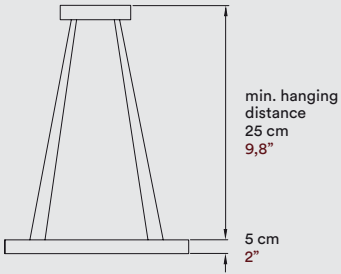

LARGE

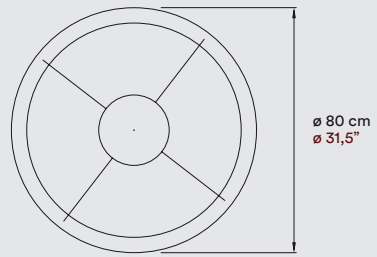
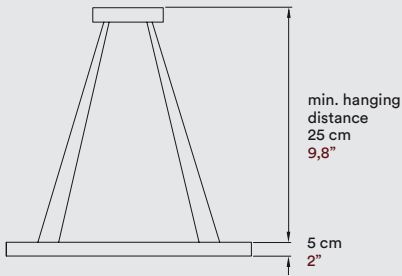

MATERIALS & COMPONENTS

Wood Veneer Shade

Bottom Acrylic Diffuser

Metal Canopy

2 Steel Cables

2,5 m drop 8 ft drop

2 Electrified Cables

2,5 m drop 8 ft drop

FINISHES

WOOD VENEER

- 20 Ivory White
- 26 Red
- 21 Natural Cherry
- 28 Blue
- 22 Natural Beech
- 29 Grey
- 24 Yellow
- 33 Pale Rose
- 25 Orange
- 34 Sea Blue

LIGHT SOURCE

120 - 277V

LED Integrated

Dimmable 0-10V, Bluetooth or DALI

Class I

120 - 277V

LED Integrated

Dimmable 0-10V & TRIAC

METAL CANOPY

- BK-Matt Black
- NI-Matt Nickel
- WH-Matt White



● **OH!LINE - SUSPENSION**

20 Ivory White Wood Veneer.

"Refugio en la Viña". Valencia, Spain. Architect: Ramón Esteve Estudio.



I-Line is a smooth and sleek lamp, with a clean, architectural line. Designed by long-time LZF collaborator Burkhard Dämmer, I-Line is available in two sizes: medium and large suspension.

I-Line's unfussy design is perfect in places and spaces that call for a practical, yet elegant,

luminaire: above a countertop or a work table, for example. I-Line's wood veneer, dimmable LED, and light-filtering diffuser, provide both direct and ambient light. In I-Line, Burkhard Dämmer has created a lamp that is simple, symmetrical and serene.

● **I-LINE - SUSPENSION**

20 Ivory White Wood Veneer.

"Refugio en la Viña". Valencia, Spain. Architect: Ramón Esteve Estudio



SHORT

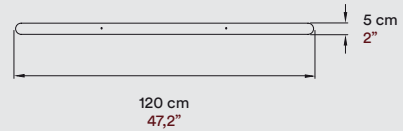
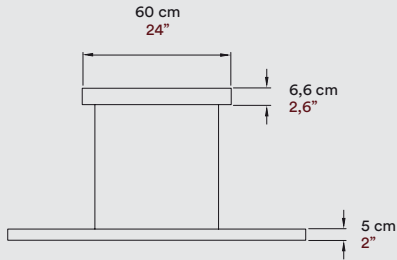

LONG

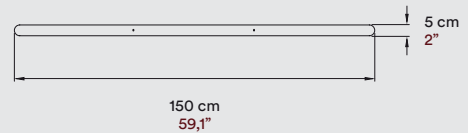
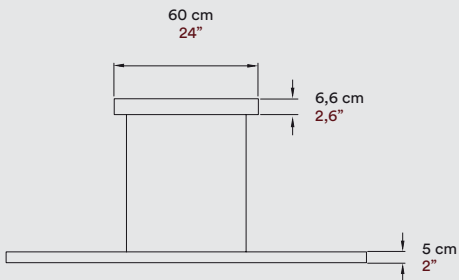

MATERIALS & COMPONENTS

Wood Veneer Shade

Bottom Acrylic Diffuser

Metal Canopy

2 Electrified Cables

2,5 m drop 8 ft drop

LIGHT SOURCE

120 - 277V

LED Integrated

Dimmable 0-10V, Bluetooth or DALI

Class I 

120 - 277V

LED Integrated

Dimmable 0-10V & TRIAC





FINISHES

WOOD VENEER

- | | | | |
|-------------------------------------------------------------------------------------|-------------------|-------------------------------------------------------------------------------------|--------------|
|  | 20 Ivory White |  | 26 Red |
|  | 21 Natural Cherry |  | 28 Blue |
|  | 22 Natural Beech |  | 29 Grey |
|  | 24 Yellow |  | 33 Pale Rose |
|  | 25 Orange |  | 34 Sea Blue |

METAL CANOPY

- | | | | |
|-------------------------------------------------------------------------------------|---------------|-------------------------------------------------------------------------------------|----------------|
|  | BK-Matt Black |  | NI-Matt Nickel |
|  | WH-Matt White | | |



- **I-LINE - SUSPENSION**
20 Ivory White Wood Veneer.



- **I-LINE - SUSPENSION**
26 Red Wood Veneer.



Maruja

Designed by:
Gazpacho Studio

An original self-assembly pendant, Maruja was designed by the fresh-faced Gazpacho Studio—it is LZF's first flat-pack fixture. A contemporary lamp, Maruja's design is simultaneously unfussy and decorative. Maruja is a name whose origins lie in Galicia, and signifies both femininity and strength.

The do-it-yourself Maruja is packaged with all the components needed to assemble the lamp: wood veneer strips (in several sizes), a circular frame, and pins. Maruja is easily constructed, without the need for any tools or adhesives. Using a pin, each wooden strip is clipped onto the circular frame—insert a light bulb, and you will have created an elegant, handmade lamp. The wood veneer strips hang and move freely, and when illuminated, Maruja sparkles with life.

-
- **MARUJA - SUSPENSION**
33 Pale Rose Wood Veneer.



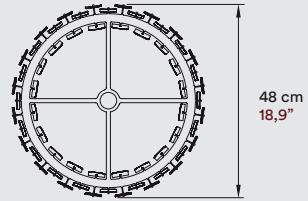
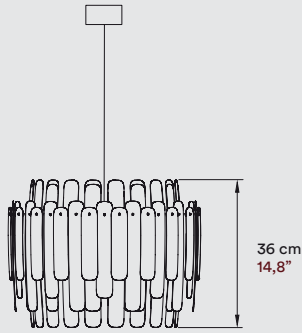

MATERIALS & COMPONENTS

Wood Veneer Shade

Metal Tripod

Metal Canopy

Electrical Cable
2,5 m drop 8 ft drop

LIGHT SOURCE

220 - 250V
Bulb E27

Class I

120 - 277V
Bulb E26

US

FINISHES

WOOD VENEER

- 20 Ivory White
- 21 Natural Cherry
- 22 Natural Beech
- 24 Yellow
- 25 Orange
- 26 Red
- 28 Blue
- 29 Grey
- 33 Pale Rose
- 34 Sea Blue

METAL CANOPY

- BK-Matt Black
- NI-Matt Nickel
- WH-Matt White



● **MARUJA - SUSPENSION**
22 Natural Beech Wood Veneer.



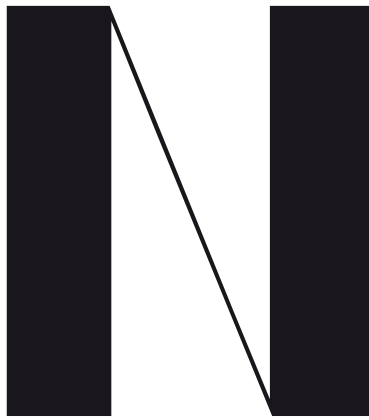
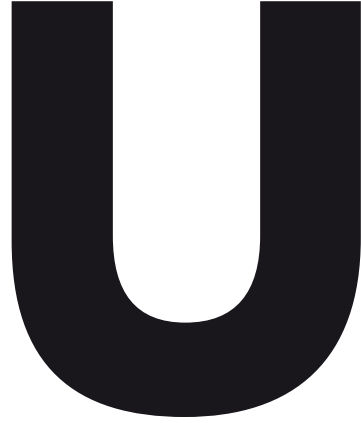

Suns

Designed by:
Mikiya Kobayashi

Small
Medium
Large

Suns is a celestial-like decorative panel that acts to diffuse light and break sound. Designed by Tokyo & Valencia-based Mikiya Kobayashi, Suns is available in three sizes: small, medium, and large.

Japan is affectionately known as the 'land of the rising sun', and in Suns we find a handmade,

circular wood panel that is characterised by a quiet and respectful beauty-an inherent Japanese quality. Without light or electrification, the Suns panel is made up of wood veneer and a metal canopy. Designed to hang at an angle, Suns is striking and stellar when placed in a cluster formation.



● **SUNS - DECORATIVE PANEL**

20 Ivory White Wood Veneer.

"Kaido" Japanese Restaurant, Valencia, Spain.

SMALL

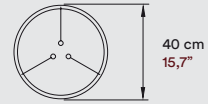

MEDIUM

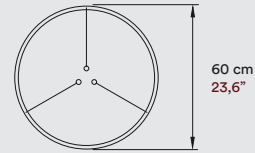

LARGE

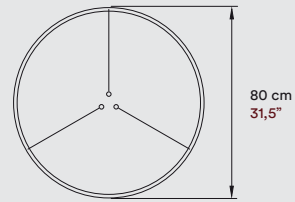
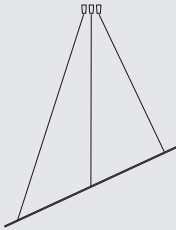

MATERIALS & COMPONENTS

Wood Veneer Panel

Metal Structure

3 Steel Cables

2,5 m drop 8 ft drop

FINISHES

WOOD VENEER

● 20 Ivory White

**THIS FIXTURE IS NOT ELECTRIFIED AND
CONTAINS NO LIGHT SOURCE**

“Suns are innovative decorative circular panels that can be installed at different angles and that break up sound and interact with light. Do not contain light source”.



● **SUNS - DECORATIVE PANEL**



20 Ivory White Wood Veneer.

"Refugio en la Viña". Valencia, Spain.

Architect: Ramón Esteve Estudio.

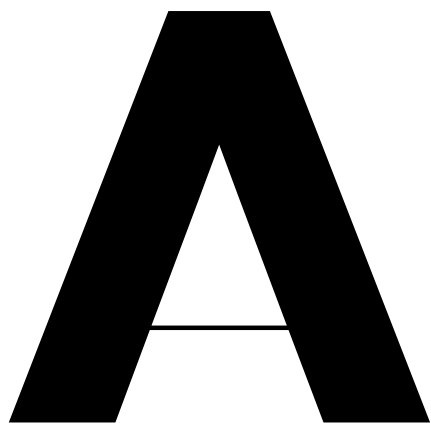

THE COLLEC TION

A large, bold, black letter 'A' is centered in the upper half of the page. It has a thick, uniform stroke and a simple, geometric design. A thin horizontal line is visible across the middle of the letter, likely a scanning artifact or a design detail.A small, solid black square is located in the upper right corner of the page.Large, bold, black letters 'G' and 'A' are positioned in the middle of the page. The 'G' is on the left and the 'A' is on the right. Both letters are thick and have a simple, geometric design. A thin horizontal line is visible across the middle of the 'A', likely a scanning artifact or a design detail.

Agatha

Designed by:
Luis Eslava Studio

Ball
Small
Large

With an arresting and dramatic demeanour, Agatha fills the room with her ambient glow and appealing body. Agatha's elegant interlacing whorls of handmade wood veneer strips spring concentrically from its centre, their mass blossoming and flourishing.



● **AGATHA - SMALL SUSPENSION**

20 Ivory White Wood Veneer. "Alameda" Restaurant. Madrid, Spain.
Architect: José Castro. Interior Designer: Evangelia Chalastsakos.

BALL

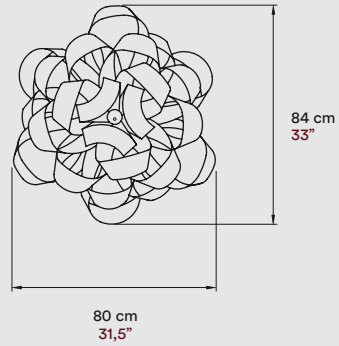
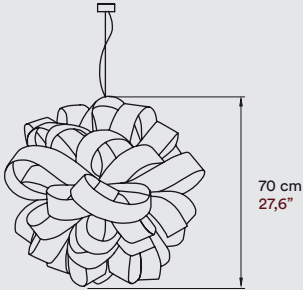

MATERIALS & COMPONENTS

Wood Veneer Shade

Metal Canopy

Steel Cable

2,5 m drop 8 ft drop

Electrical Cable

2,5 m drop 8 ft drop

FINISHES

WOOD VENEER

- 20 Ivory White
- 25 Orange
- 22 Natural Beech
- 33 Pale Rose
- 24 Yellow

LIGHT SOURCE

120 - 277V

LED Integrated
Dimmable 0-10V, Bluetooth or DALI
or

220 - 250V

6 Bulbs E27

Class I

120 - 277V

LED Integrated
Dimmable 0-10V & TRIAC
or

120 - 277V

6 Bulbs E26



AWARDS

HD Las Vegas. Product Design Competition. USA

WAN LIGHTING. World Architecture Award. USA



- **AGATHA - SMALL SUSPENSION**
20 Ivory White Wood Veneer.

- **AGATHA - BALL SUSPENSION**
20 Ivory White Wood Veneer.
"Palau de Casavells". Girona, Spain.

- **AGATHA - LARGE SUSPENSION**
20 Ivory White Wood Veneer.
"Villa El Nido". Architects: A-cero. Marbella, Spain.



SMALL

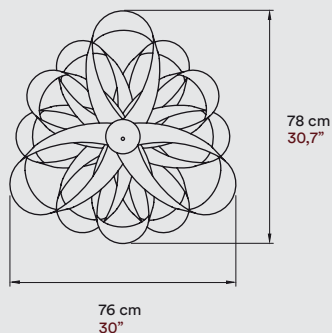
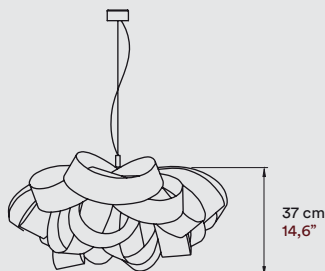

MATERIALS & COMPONENTS

Wood Veneer Shade

Metal Canopy

Steel Cable

2,5 m drop 8 ft drop

Electrical Cable

2,5 m drop 8 ft drop

LIGHT SOURCE

120 - 277V

LED Integrated

Dimmable 0-10V, Bluetooth or DALI

or

220 - 250V

Bulb E27

Class I **120 - 277V**

LED Integrated

Dimmable 0-10V & TRIAC

or



120 - 277V

Bulb E26



FINISHES

WOOD VENEER

| | | | |
|-------------------------------------------------------------------------------------|-------------------|-------------------------------------------------------------------------------------|--------------|
|  | 20 Ivory White |  | 26 Red |
|  | 21 Natural Cherry |  | 28 Blue |
|  | 22 Natural Beech |  | 29 Grey |
|  | 24 Yellow |  | 33 Pale Rose |
|  | 25 Orange |  | 34 Sea Blue |

LARGE

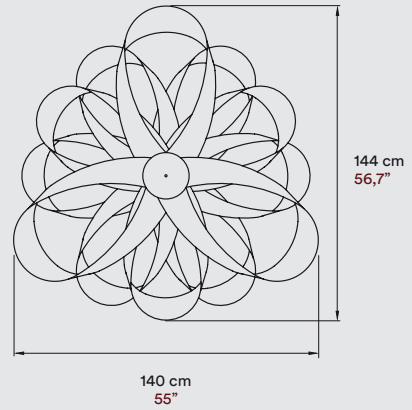
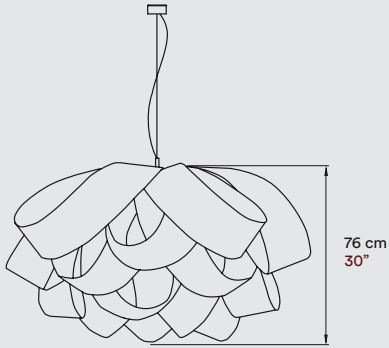

MATERIALS & COMPONENTS

Wood Veneer Shade

Metal Canopy

Steel Cable

2,5 m drop 8 ft drop

Electrical Cable

2,5 m drop 8 ft drop

LIGHT SOURCE

120 - 277V

LED Integrated

Dimmable 0-10V, Bluetooth or DALI

or

220 - 250V

3 Bulbs E27

Class I **120 - 277V**

LED Integrated

Dimmable 0-10V & TRIAC

or









120 - 277V

3 Bulbs E26



FINISHES

WOOD VENEER

| | | | |
|-------------------------------------------------------------------------------------|-------------------|-------------------------------------------------------------------------------------|--------------|
|  | 20 Ivory White |  | 26 Red |
|  | 21 Natural Cherry |  | 28 Blue |
|  | 22 Natural Beech |  | 29 Grey |
|  | 24 Yellow |  | 33 Pale Rose |
|  | 25 Orange |  | 34 Sea Blue |

AIR



Air

Table
Wall

Designed by:
Ray Power

The Air light is sublime, graceful and enchanting. Its shape exhibits the designer's characteristic penchant for imaginative three-dimensional forms. The Air lamp's pleats and folds work to create a unique wood veneer light, one whose character demonstrates balance with equanimity and restraint.

Air lamp diffuses light in a manner that is flawless and low-key, its singular silhouette shining with a radiant warmth and vitality. A free-flowing, effortless light, Air lamp enjoys a distinctly individual profile.

-
- **AIR - WALL**
20 Ivory White Wood Veneer. "Caro" Hotel. Valencia, Spain.



● **AIR - TABLE**
24 Yellow Wood Veneer. "Villa El Nido". Architects: A-cero. Marbella, Spain.

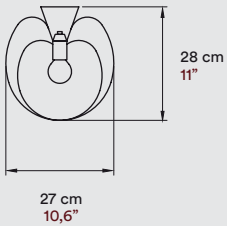
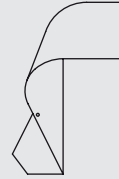
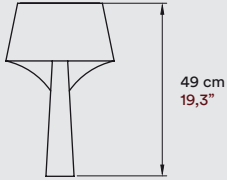

MATERIALS & COMPONENTS

Wood Veneer Shade

Metal Base

Electrical Cable with Dimming Switch
145 cm 57"

LIGHT SOURCE

220 - 250V
Bulb E14

Class II

120V
Bulb E12



FINISHES

WOOD VENEER

- 20 Ivory White
- 26 Red
- 21 Natural Cherry
- 28 Blue
- 22 Natural Beech
- 29 Grey
- 24 Yellow
- 33 Pale Rose
- 25 Orange
- 34 Sea Blue

AWARDS



Chicago

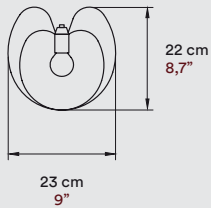
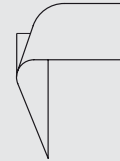
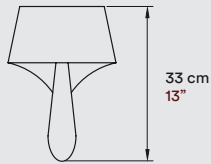

MATERIALS & COMPONENTS

Wood Veneer Shade

Metal Back Plate

LIGHT SOURCE

220 - 250V
Bulb E14

Class I

120V
Bulb E12

FINISHES

WOOD VENEER

- | | |
|-------------------|--------------|
| 20 Ivory White | 26 Red |
| 21 Natural Cherry | 28 Blue |
| 22 Natural Beech | 29 Grey |
| 24 Yellow | 33 Pale Rose |
| 25 Orange | 34 Sea Blue |



Banga

Designed by:
Yonoh Creative Studio

Medium
Large

The Banga light's combined veneer pieces and metal frame bear a resemblance to a plush broly or indeed, to a well dressed parasol. Banga enjoys an expressive Eastern world-like quality, together with a nod to neoclassicism and its principles of simplicity and symmetry.

• **BANGA - LARGE SUSPENSION**

26 Red Wood Veneer. "Le Meridien" Hotel. Tarragona, Spain.



MEDIUM

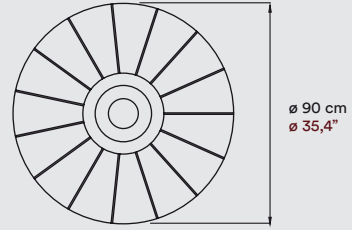
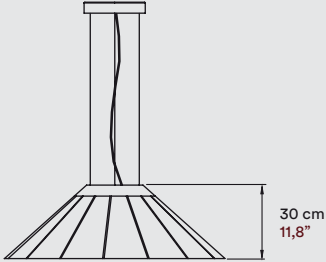

LARGE

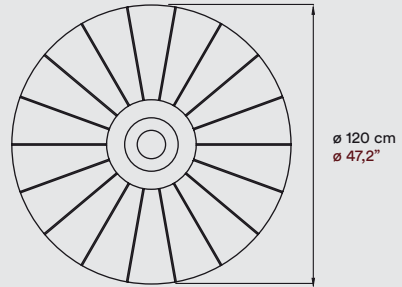
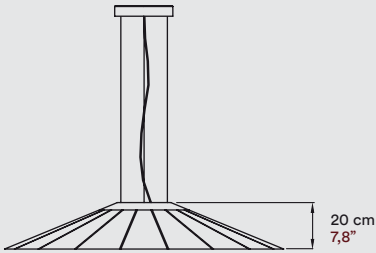

MATERIALS & COMPONENTS

Wood Veneer Shade

Acrylic Diffuser

Metal Structure & Canopy

3 Steel Cables

2,5 m drop 8 ft drop

Electrical Cable

2,5 m drop 8 ft drop

LIGHT SOURCE

120 - 277V

LED Integrated

Dimmable 0-10V, Bluetooth or DALI

Class I CE

120 - 277V

LED Integrated

Dimmable 0-10V & TRIAC



FINISHES

WOOD VENEER

- 20 Ivory White
- 26 Red
- 21 Natural Cherry
- 28 Blue
- 22 Natural Beech
- 29 Grey
- 24 Yellow
- 33 Pale Rose
- 25 Orange
- 34 Sea Blue

AWARDS



Chicago



Germany



● **BANGA - LARGE & MEDIUM SUSPENSION**
33 Pale Rose, 24 Yellow & 29 Grey Wood Veneer.
"Le Meridien" Hotel. Tarragona, Spain.

B L A C K N O T E

Black Note

Keys
Triplet
Duplet

Suspension
Susp. & Floor
Wall

Designed by Ramón Esteve, Black Note is a lamp with perpendicular shades that rise and fall in harmony. Its rhythmic arrangement is inspired by the black keys on a piano, whose sharp and flat notes add emotion and passion to a melody.

Black note's metal frame in our new metallic finishes work, works harmoniously with its luminous, warm wood veneer shades. Ramón Esteve created three Black Note compositions: Black Note Keys (horizontal), Black Note Triplets (suspension & floor) and Black Note Duplets (wall). These differing compositions, with their rhythmic forms, offer a symphony of light, texture and pattern.

● BLACK NOTE KEYS - SUSPENSION

20 Ivory White Wood Veneer & Matt Black Metal Structure & Canopy.
"Casa en la Huerta". Valencia, Spain. Architect: Ramón Esteve Estudio.



K

Designed by:
Ramón Esteve Estudio

F





● **BLACK NOTE KEYS - SUSPENSION**

22 Natural Beech Wood Veneer & Gold Metal Structure & Canopy.

The Black Note Keys has dual electrical circuits. Both circuits can be dimmed independently of one another making an almost infinite combination of light blends possible.



KEYS

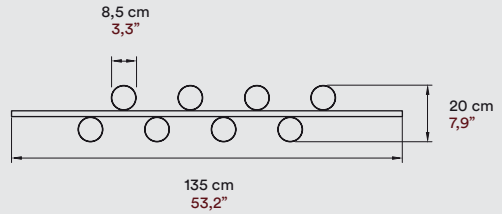
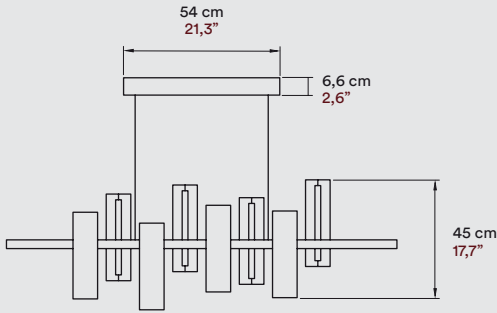

MATERIALS & COMPONENTS

8 Wood Veneer Shades

Metal Structure & Canopy

4 Electrified Steel Cables

2,5 m drop 8 ft drop

FINISHES

WOOD VENEER

- 20 Ivory White
- 22 Natural Beech
- 21 Natural Cherry
- 29 Grey

LIGHT SOURCE

Dual Circuit - DC. Enables independent dimming and control of the decorative wood shades and the tech downlight.

120 - 277V

Class I

LED Integrated

Dimmable 0-10V, Bluetooth or DALI

120 - 277V

LED Integrated

Dimmable 0-10V & TRIAC

METAL

- IV-Matt Ivory
- NI-Matt Nickel
- BK-Matt Black
- GD-Gold



● **BLACK NOTE KEYS - SUSPENSION**
21 Natural Cherry Wood Veneer & Matt Black Metal Structure & Canopy.

TRIPLET

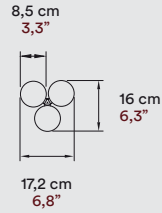
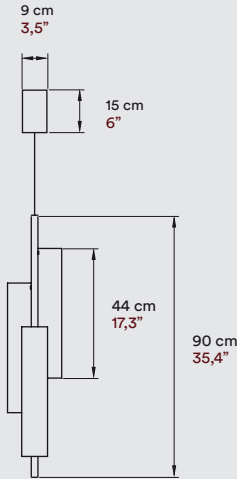

MATERIALS & COMPONENTS

3 Wood Veneer Shades

Metal Structure & Canopy

Electrical Cable

2,5 m drop 8 ft drop

FINISHES

WOOD VENEER

- 20 Ivory White
- 22 Natural Beech
- 21 Natural Cherry
- 29 Grey

LIGHT SOURCE

120 - 277V

LED Integrated

Dimmable 0-10V, Bluetooth or DALI

Class I

METAL

- IV-Matt Ivory
- NI-Matt Nickel
- BK-Matt Black
- GD-Gold

120 - 277V

LED Integrated

Dimmable 0-10V & TRIAC



● **BLACK NOTE TRIPLET - SUSPENSION**
20 Ivory White Wood Veneer & Gold Metal Structure & Canopy.



● **BLACK NOTE TRIPLET - SUSPENSION**

20 Ivory White & 21 Natural Cherry Wood Veneer with Ivory White & Matt Black Metal Structure.



● **BLACK NOTE TRIPLET - SUSPENSION**
22 Natural Beech & 29 Grey Wood Veneer with Gold & Matt Black Metal Structure.

TRIPLET

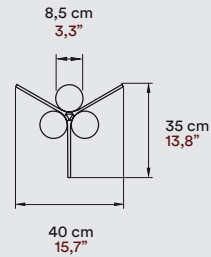
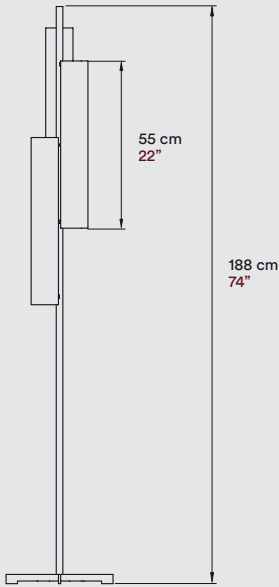

MATERIALS & COMPONENTS

3 Wood Veneer Shades

Metal Stem & Base

Electrical Cable with Dimming Switch

185 cm 73"

LIGHT SOURCE

230V
LED Integrated Dimmable

Class II

120V
LED Integrated Dimmable

FINISHES

WOOD VENEER

- 20 Ivory White
- 22 Natural Beech
- 21 Natural Cherry
- 29 Grey

METAL

- IV-Matt Ivory
- NI-Matt Nickel
- BK-Matt Black
- GD-Gold



● **BLACK NOTE TRIPLET - FLOOR**

20 Ivory White Wood Veneer & Matt Black Metal Base.

"Casa en la Huerta". Valencia, Spain. Architect: Ramón Esteve Estudio.

DUPLET

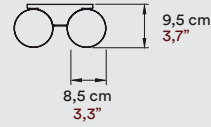
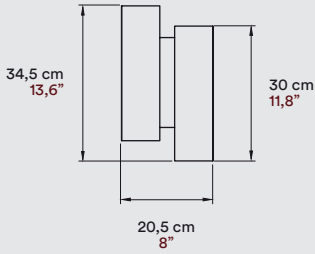

MATERIALS & COMPONENTS

2 Wood Veneer Shades

Metal Back Plate

FINISHES

WOOD VENEER

- 20 Ivory White
- 22 Natural Beech
- 21 Natural Cherry
- 29 Grey

LIGHT SOURCE

120 - 277V
LED Integrated
Dimmable 0-10V

Class I

120 - 277V
LED Integrated
Dimmable 0-10V & TRIAC



METAL

- IV-Matt Ivory
- NI-Matt Nickel
- BK-Matt Black
- GD-Gold

ADA Compliant



● **BLACK NOTE DUPLET - WALL**

29 Grey Wood Veneer & Matt Black Metal Back Plate. Photo: 4000k.

"Casa en la Huerta". Valencia, Spain. Architect: Ramón Esteve Estudio.

CANDELABRO

Candelabro

Small
Large

Designed by:
Mariví Calvo

Imagine a suspension light that embodies many of LZFF's greatest hits. Candelabro describes a remarkably representational form that unites the finest collection of wood veneer pendants. The performers include such luminaries as Agatha and Mikado, Raindrop and Totem. Hovering amid the lights are a number of golden birds, each one enjoying a magical world of wonder. Together, these birds and the various pendants stage a thrilling opus in light, a majestic piece that will give the viewer pleasure every time.

- **CANDELABRO - SMALL SUSPENSION**
20 Ivory White Wood Veneer. "Alameda" Restaurant. Madrid, Spain.





SMALL

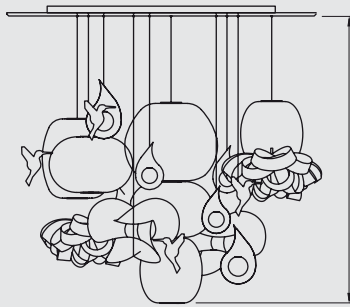

230 cm
90,5"

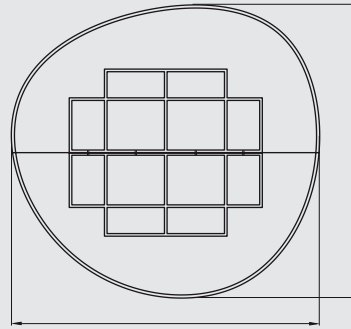

224 cm
87"

236 cm
96,5"

LARGE

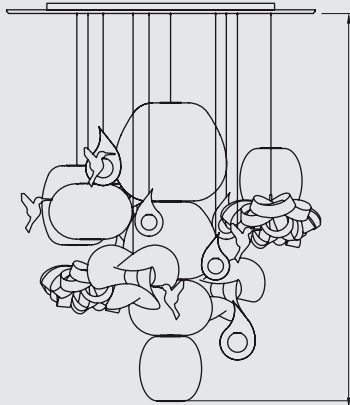

308 cm
121"

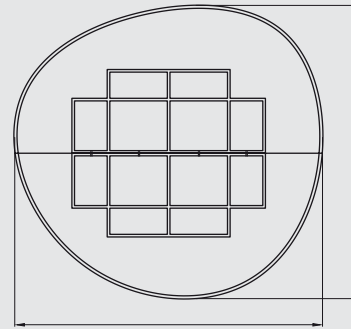

224 cm
87"

236 cm
96,5"

MATERIALS & COMPONENTS

15 Wood Veneer Shades

Lacquered Wood Canopy

Ceramic Birds in Gold or White Glaze

FINISHES

WOOD VENEER

20 Ivory White

22 Natural Beech

LIGHT SOURCE

3 Independent Dimmable Circuits.
Dimming & Control of the Central Shade,
Periferal Shades & Soptlights.

220 - 250V

Class I CE

120V





● CANDELABRO
LARGE SUSPENSION
20 Ivory White Wood Veneer.
LZF Showroom. Chiva, Valencia.



• **CANDELABRO CUSTOM SUSPENSION**

21 Natural Cherry Wood Veneer. GF Gran Costa Adeje Hotel*****, Tenerife, Spain. Project: Mayte Calzadilla (Architect GRUPO FEDOLA). Tech. Dep.: KAUXEX.



Photography: Richard Goncalves.

Carambola

Small
Medium



Designed by:
Oskar Cerezo

MBC
MBA
OLA
A

SMALL

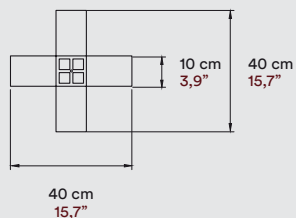
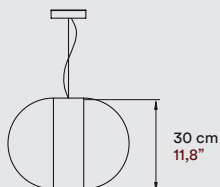

MEDIUM

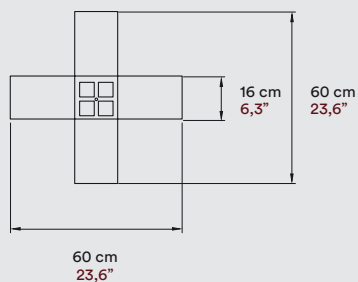
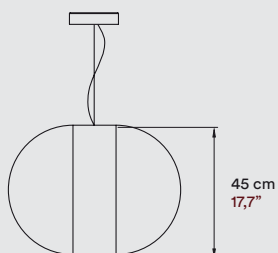

MATERIALS & COMPONENTS

Wood Veneer Shade

Acrylic Diffuser

Metal Trims & Canopy

Steel Cable



2,5 m drop 8 ft drop

Electrical Cable

2,5 m drop 8 ft drop

FINISHES

WOOD VENEER

- | | | | |
|-------------------------------------------------------------------------------------|-------------------|-------------------------------------------------------------------------------------|--------------|
|  | 20 Ivory White |  | 26 Red |
|  | 21 Natural Cherry |  | 28 Blue |
|  | 22 Natural Beech |  | 29 Grey |
|  | 24 Yellow |  | 33 Pale Rose |
|  | 25 Orange |  | 34 Sea Blue |

LIGHT SOURCE

120 - 277V

LED Integrated

Dimmable 0-10V, Bluetooth or DALI

Class I 

120 - 277V

LED Integrated

Dimmable 0-10V & TRIAC





● **CARAMBOLA - SMALL SUSPENSION**
21 Natural Cherry Wood Veneer.
"Caro" Hotel. Valencia, Spain.

MINI CHOU





Mini Chou

Designed by:
Yonoh Creative Studio

The simplicity and charm of the Mini Chou, inspired by the traditional Japanese lantern called chou-chin, is able to capture the enchantment of the moment through light.

Mini Chou is the perfect companion for modern life: wireless, handy and exceptionally versatile. Handmade in natural wood veneer in Spain, Mini Chou has a dimmer that allows you to create the level of intimacy required.

With a whole world to discover, just how far will your Mini Chou take you?

- **MINI CHOU - CORDLESS TABLE**

20 Ivory White Wood Veneer.

"Refugio en la Viña". Valencia, Spain. Architect: Ramón Esteve Estudio.

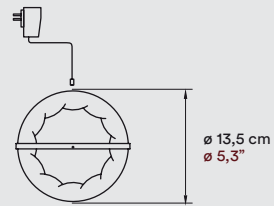
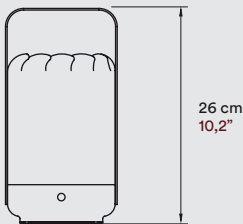

MATERIALS & COMPONENTS

Wood Veneer Shade

Acrylic Diffuser

Metal Base & Handle

Rechargeable Battery

8 Hours Autonomy at 90% Power

IN Charge

USB type C

On / Off Dimming

LIGHT SOURCE

LED Integrated Dimmable

Class III ⚡ CE

LED Integrated Dimmable

FINISHES

WOOD VENEER

- 20 Ivory White
- 29 Grey
- 22 Natural Beech
- 33 Pale Rose
- 26 Red
- 34 Sea Blue
- *On Request: 24 Yellow



● MINI CHOU - CORDLESS TABLE
22 Natural Beech Wood Veneer.



C

H

O

U

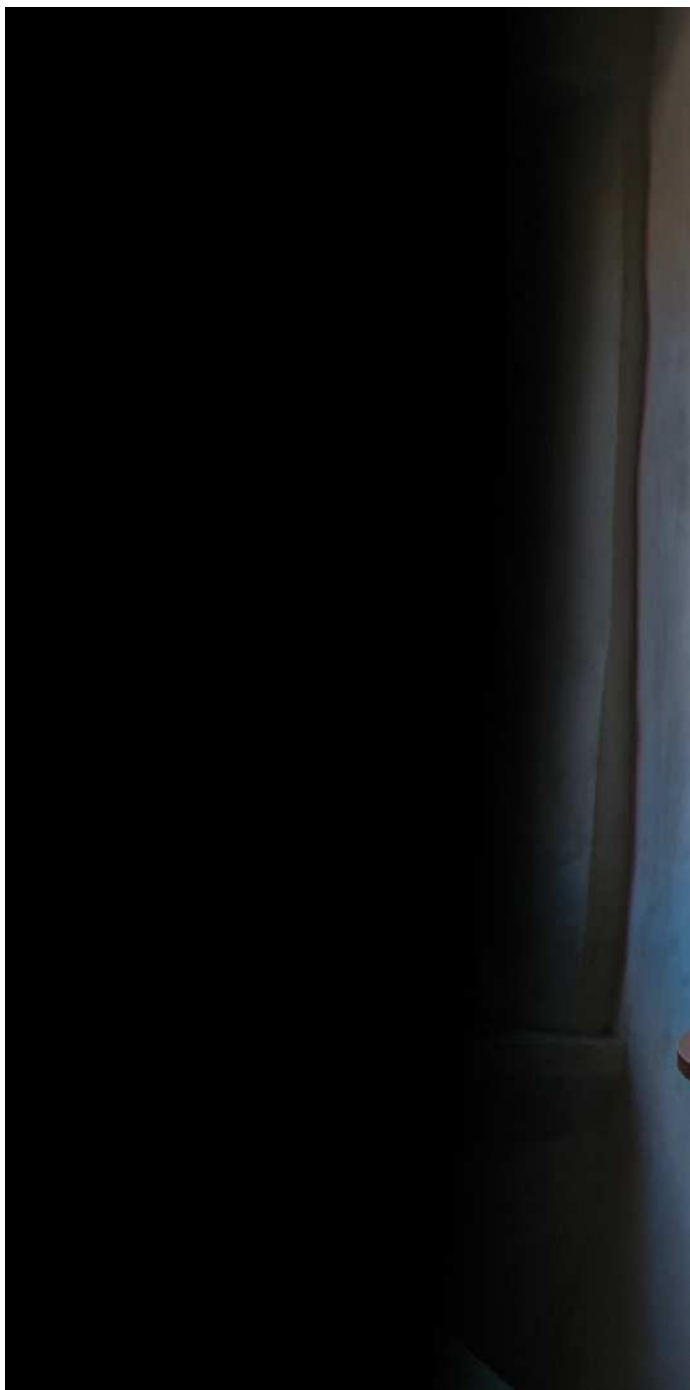

-
- **CHOU - TALL TABLE**
21 Natural Cherry Wood Veneer.
"Palau de Casavells". Girona, Spain.



Chou

Table

Designed by:
Yonoh Creative Studio

Designed by Yonoh Creative Studio, the Chou lamp is available in two table versions. This deceptively simple light is especially pleasing when presented in a cluster of differing sizes. The Chou lamp catches the eye with its carefully considered pose.

SHORT

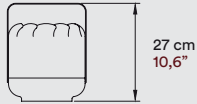

TALL

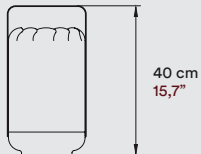

MATERIALS & COMPONENTS

Wood Veneer Shade

Metal Base & Handle

Electrical Cable with Dimming Switch
130 cm 49"

LIGHT SOURCE

220 - 250V

Bulb E27

Class II 

120V

Bulb E26



FINISHES

WOOD VENEER

- | | | | |
|-------------------------------------------------------------------------------------|-------------------|-------------------------------------------------------------------------------------|--------------|
|  | 20 Ivory White |  | 26 Red |
|  | 21 Natural Cherry |  | 28 Blue |
|  | 22 Natural Beech |  | 29 Grey |
|  | 24 Yellow |  | 33 Pale Rose |
|  | 25 Orange |  | 34 Sea Blue |

AWARDS



Germany



● CHOU - SHORT TABLE
33 Pale Rose Wood Veneer.
"Palau de Casavells". Girona, Spain.

C



A

Cuad

Designed by:
Burkhard Dämmer

-
- **CUAD - SUSPENSION**
21 Natural Cherry Wood Veneer. "MSK Koch Center" Hospital. NY, USA. Photography: Chris Cooper.

U



The Cuad light is an architecturally pertinent pendant and one that illuminates a space with equanimity. The Cuad's wood veneer cuboid shape recalls the spirit of midcentury modern style with an understated elegance. Yet beneath that calm exterior, powerful electronic technology works with tremendous fervour to ensure that Cuad delivers its versatile light across a range of interior environments.

D

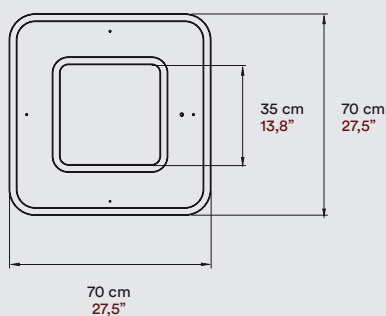
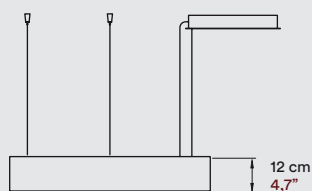

MATERIALS & COMPONENTS

Wood Veneer Shade

Top & Bottom Acrylic Diffuser

Metal Canopy

Electrical Cable

2,5 m drop 8 ft drop

4 Steel Cables

2,5 m drop 8 ft drop

FINISHES

WOOD VENEER

- | | | | |
|-------------------------------------------------------------------------------------|-------------------|-------------------------------------------------------------------------------------|--------------|
|  | 20 Ivory White |  | 26 Red |
|  | 21 Natural Cherry |  | 28 Blue |
|  | 22 Natural Beech |  | 29 Grey |
|  | 24 Yellow |  | 33 Pale Rose |
|  | 25 Orange |  | 34 Sea Blue |

LIGHT SOURCE

120 - 277V

LED Integrated

Dimmable 0-10V, Bluetooth or DALI

Class I 

120 - 277V

LED Integrated

Dimmable 0-10V & TRIAC





- **CUAD - SUSPENSION**
21 Natural Cherry Wood Veneer.
"Villa El Nido". Marbella, Spain.
Architects: A-cero Atchitects.

- **CUAD - SUSPENSION**
21 Natural Cherry Wood Veneer.



D

A

N

D

Dandelion

Designed by:
Burkhard Dämmer

Bearing a resemblance to its flowering namesake, this lamp is a radiant composite of many single florets. Independent and distinct, each funnel-shaped floret appears to shine alone, yet en masse they create the Dandelion's sparkle.



• DANDELION - SUSPENSION
26 Red Wood Veneer.

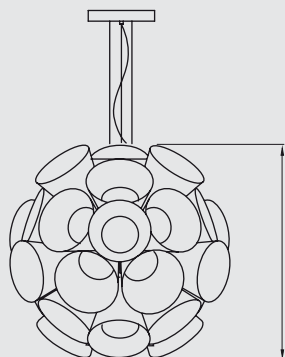

81 cm
31,9"

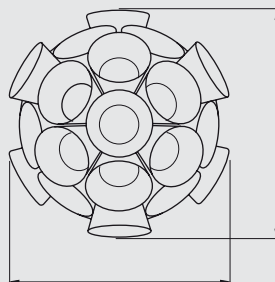

85 cm
33,5"

85 cm
33,5"

MATERIALS & COMPONENTS

Wood Veneer Shade

Acrylic Diffusers

Metal Canopy

3 Steel Cables









2,5 m drop 8 ft drop

Electrical Cable

2,5 m drop 8 ft drop

FINISHES

WOOD VENEER

- | | | | |
|-------------------------------------------------------------------------------------|-------------------|-------------------------------------------------------------------------------------|--------------|
|  | 20 Ivory White |  | 26 Red |
|  | 21 Natural Cherry |  | 28 Blue |
|  | 22 Natural Beech |  | 29 Grey |
|  | 24 Yellow |  | 33 Pale Rose |
|  | 25 Orange |  | 34 Sea Blue |

LIGHT SOURCE

120 - 277V

LED Integrated

Dimmable 0-10V, Bluetooth or DALI

Class I 

120 - 277V

LED Integrated

Dimmable 0-10V



AWARDS



Chicago



Germany



Brussels

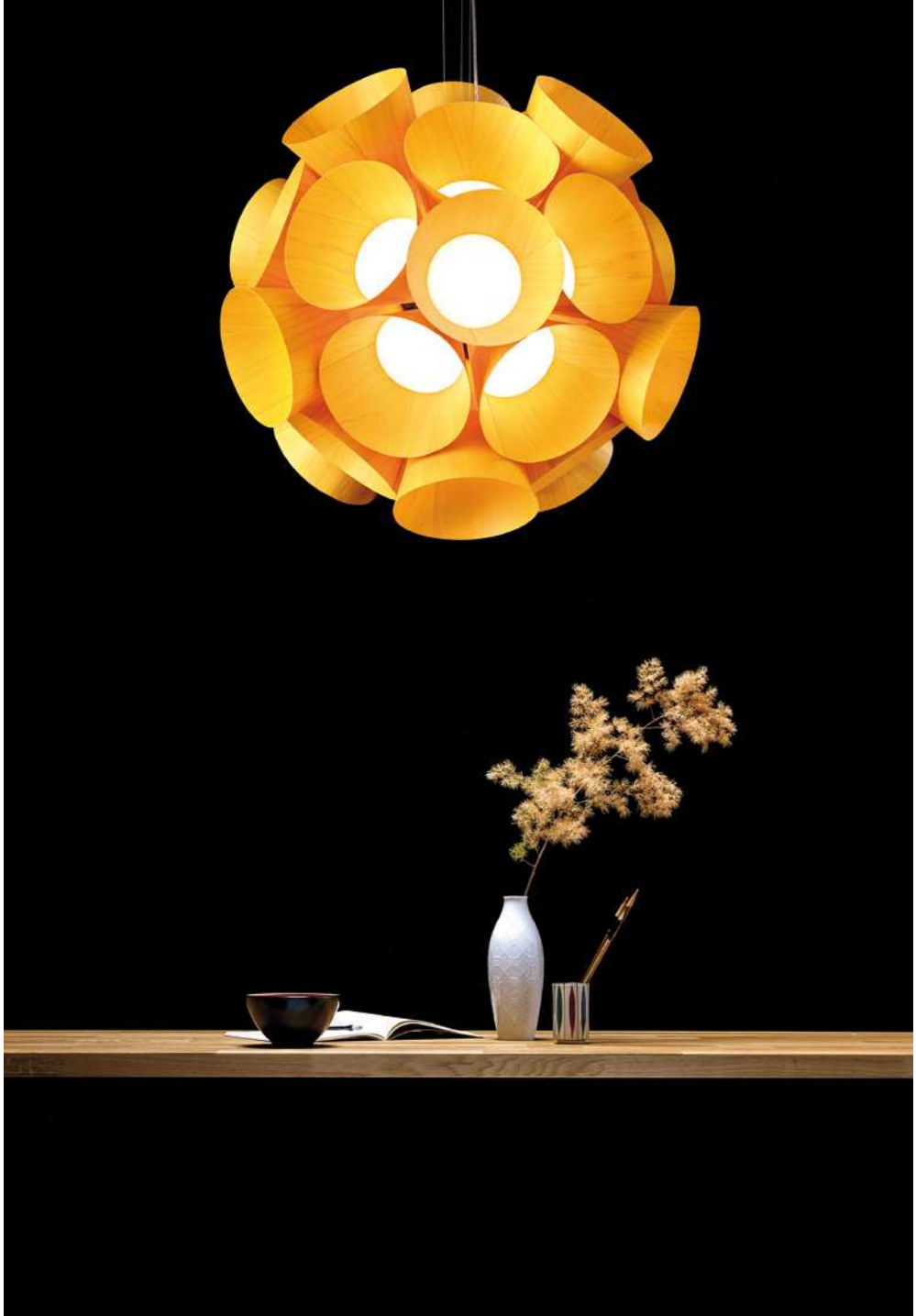

● DANDELION - SUSPENSION
24 Yellow Wood Veneer.

Domo

Designed by:
Rqr Studio



With its handsome form, Domo is reserved, strong and aesthetically presented. This lamp consists of two layers: an outer layer formed using four interlocking timber veneer slats and an inner layer fashioned from seamless veneer joints. In history, the dome is a structure that exhibits strength. It is therefore fitting that Domo is an earnest light, with an inner flame and passion that truly shines.

Domo reflects light downwards and is perfect for a variety of tasks and chores. Pure, simple and practical, Domo is delightfully earnest.

● **DOMO - SUSPENSION** | 21 Natural Cherry Wood Veneer.



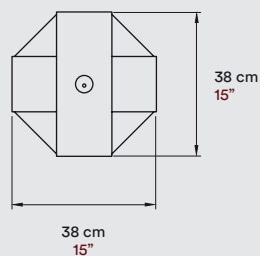
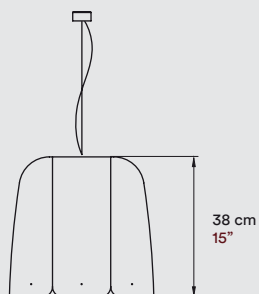

MATERIALS & COMPONENTS

Wood Veneer Shade

Metal Canopy

Steel Cable

2,5 m drop 8 ft drop

Electrical Cable

2,5 m drop 8 ft drop

LIGHT SOURCE

220 - 250V

Bulb E27

Class I 

120 - 277V

Bulb E26



FINISHES

WOOD VENEER

- | | |
|-------------------------------------------------------------------------------------------------------|--------------------------------------------------------------------------------------------------|
|  20 Ivory White |  26 Red |
|  21 Natural Cherry |  28 Blue |
|  22 Natural Beech |  29 Grey |
|  24 Yellow |  33 Pale Rose |
|  25 Orange |  34 Sea Blue |

-
- **DOMO - SUSPENSION**
24 Yellow Wood Veneer.



-
- **DOMO - SUSPENSION**
20 Ivory White Wood Veneer.



Escape

Designed by:
Ray Power

Small
Large



A large, bold, black sans-serif font showing the letters 'A', 'P', and 'E'. The 'A' has a horizontal bar, the 'P' has a curved top, and the 'E' has a horizontal bar. The letters are set against a white background.

Escape is an avant-garde pendant with a smart domino-like structure. Its self-supporting veneer panels give the impression of falling into a ring of light, their form defying gravity.

Designed by Ray Power, Escape is a truly handsome, self-assured light. While enjoying a little bit of swagger and appearing fairly pleased with itself, the Escape pendant's manner is bright and buoyant. Moreover, Escape is entirely affable, having an approachable quality that is perfect for any well turned out setting.

-
- **ESCAPE - SMALL SUSPENSION**
20 Ivory White Wood Veneer.

SMALL

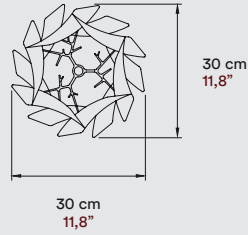
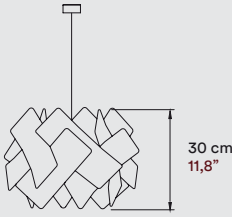

LARGE

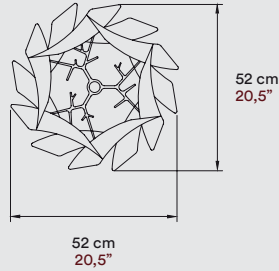
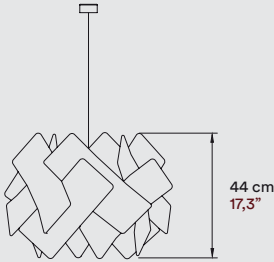

MATERIALS & COMPONENTS

Wood Veneer Shade

Metal Tripod & Canopy

Electrical Cable
2,5 m drop 8 ft drop

LIGHT SOURCE

220 - 250V
Bulb E27

Class I

120 - 277V
Bulb E26

AWARDS



Chicago

FINISHES

WOOD VENEER

- 20 Ivory White
- 26 Red
- 21 Natural Cherry
- 28 Blue
- 22 Natural Beech
- 29 Grey
- 24 Yellow
- 33 Pale Rose
- 25 Orange
- 34 Sea Blue

METAL CANOPY

- BK-Matt Black
- NI-Matt Nickel
- WH-Matt White

- **ESCAPE - SMALL & LARGE SUSPENSION**
33 Pale Rose Wood Veneer.
"La Monella" Jewellers.
Valencia, Spain.

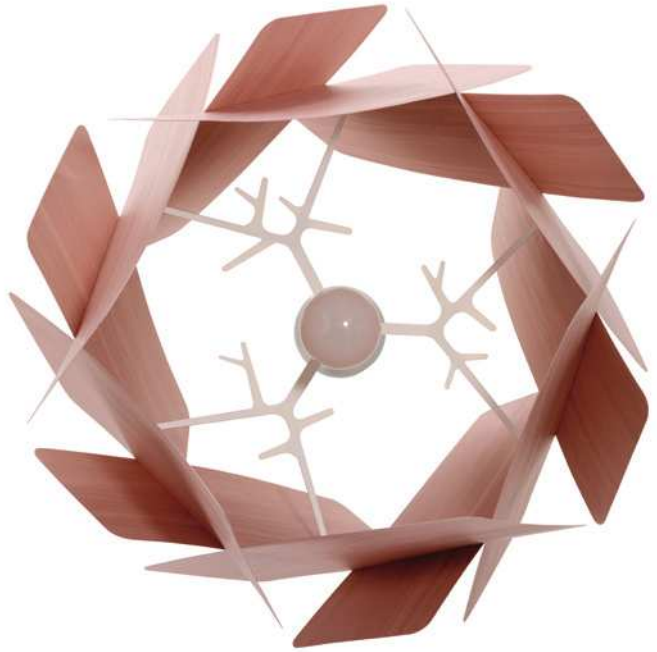

GEA

COSMOS

Suspension
Floor
Wall
Ceiling

Designed by:
Mariví Calvo

A versatile all-rounder, Gea is a solid and circular suspension, ceiling, wall and floor lamp (named 'Cosmos'). Gea's modest form is smart, self-possessed and clean-cut. A steadfast performer, Gea radiates warmth from its wood veneer sides, the resulting effect satisfyingly serene.

We find a light that is unpretentious and yet highly accomplished, its versatility knowing no bounds. From a series of Super Gea pendants hanging in the hallways of power to a Gea ceiling lamp fixed in a minimalist space, this appealing light is reassuringly loyal.



● GEA - LARGE SUSPENSION | 29 Grey Wood Veneer. Photo: 4000k.



• GEA - LARGE SUSPENSION | 29 Grey Wood Veneer. "Le Meridien" Hotel. Tarragona, Spain. Photo: 4000k.

SMALL

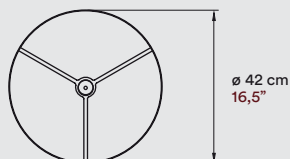
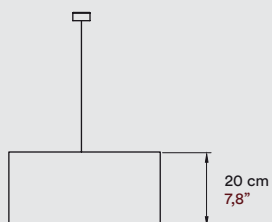

LARGE

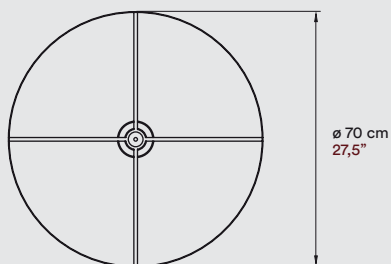
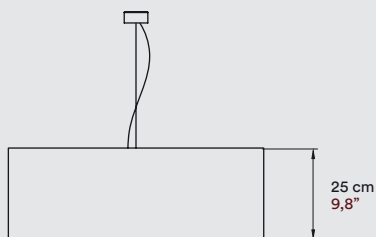

MATERIALS & COMPONENTS

Wood Veneer Shade

Acrylic Diffuser

Metal Tripod & Canopy

Steel Cable



2,5 m drop 8 ft drop Only in Large size

Electrical Cable

2,5 m drop 8 ft drop

FINISHES

WOOD VENEER

- | | | | |
|-------------------------------------------------------------------------------------|-------------------|-------------------------------------------------------------------------------------|--------------|
|  | 20 Ivory White |  | 26 Red |
|  | 21 Natural Cherry |  | 28 Blue |
|  | 22 Natural Beech |  | 29 Grey |
|  | 24 Yellow |  | 33 Pale Rose |
|  | 25 Orange |  | 34 Sea Blue |

LIGHT SOURCE

220 - 250V

Class I 

SMALL Bulb E27

LARGE 3 Bulbs E27

120 - 277V



SMALL Bulb E26

LARGE 3 Bulbs E26

SLIM

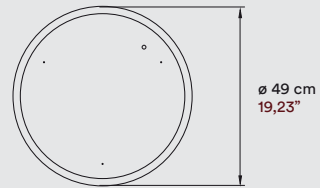
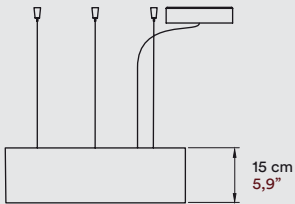

MATERIALS & COMPONENTS

Wood Veneer Shade

Top & Bottom Acrylic Diffuser

Metal Canopy

3 Steel Cables



2,5 m drop 8 ft drop

Electrical Cable

2,5 m drop 8 ft drop

FINISHES

WOOD VENEER

| | | | |
|-------------------------------------------------------------------------------------|-------------------|-------------------------------------------------------------------------------------|--------------|
|  | 20 Ivory White |  | 26 Red |
|  | 21 Natural Cherry |  | 28 Blue |
|  | 22 Natural Beech |  | 29 Grey |
|  | 24 Yellow |  | 33 Pale Rose |
|  | 25 Orange |  | 34 Sea Blue |

LIGHT SOURCE

120 - 277V

LED Integrated

Dimmable 0-10V, Bluetooth or DALI

Class I 

120 - 277V

LED Integrated

Dimmable 0-10V & TRIAC



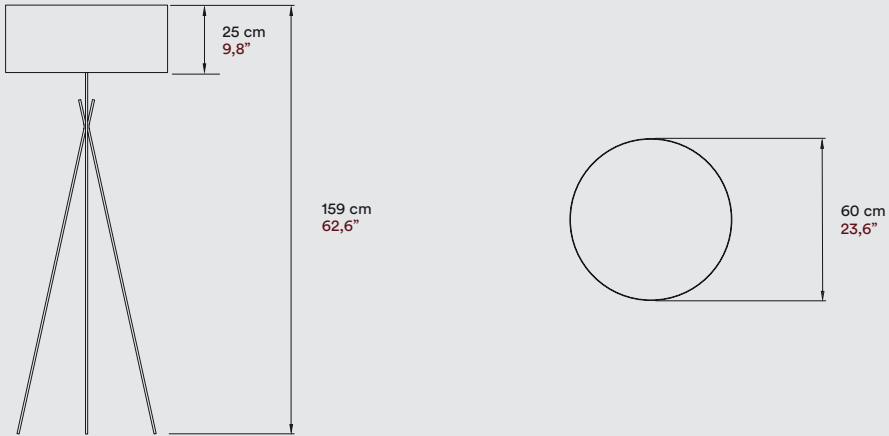

MATERIALS & COMPONENTS

Wood Veneer Shade

Acrylic Upper Diffuser

Metal Tripod & Base

Electrical Cable with Dimming Switch
185 cm 53"

LIGHT SOURCE

220 - 250V
3 Bulbs E27









Class II  

120V
3 Bulbs E26



FINISHES

WOOD VENEER

-  20 Ivory White
-  21 Natural Cherry
-  22 Natural Beech
-  24 Yellow
-  25 Orange
-  26 Red
-  28 Blue
-  29 Grey
-  33 Pale Rose
-  34 Sea Blue



● **COSMOS - FLOOR** | 20 Ivory White.
"Villa El Nido". Architects. A-cero. Marbella, Spain.

SMALL

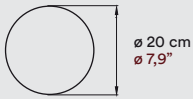

10 cm
3,9"

MEDIUM

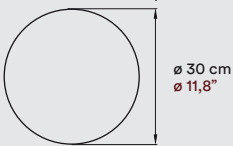

10 cm
3,9"

LARGE

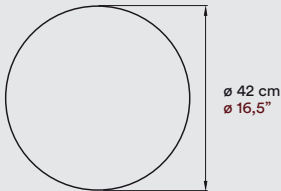

10 cm
3,9"

MATERIALS & COMPONENTS

Wood Veneer Shade

Acrylic Frontal Diffuser

Metal Back plate

LIGHT SOURCE

120 - 277V
LED Integrated
Dimmable 0-10V
or

220 - 250V
Bulb GX53

Class I

120 - 277V
LED Integrated
Dimmable 0-10V & TRIAC
or
120V
Bulb GX53



ADA Compliant

FINISHES

WOOD VENEER

- | | | | |
|--|-------------------|--|--------------|
| | 20 Ivory White | | 26 Red |
| | 21 Natural Cherry | | 28 Blue |
| | 22 Natural Beech | | 29 Grey |
| | 24 Yellow | | 33 Pale Rose |
| | 25 Orange | | 34 Sea Blue |



- **GEA LARGE CEILING**
29 Grey Wood Veneer.
Photo: 4000k.
"Le Meridien" Hotel.
Tarragona, Spain.



- **GEA - SMALL, MEDIUM & LARGE WALL**
29 Grey Wood Veneer.
Photo: 4000k.
"Le Meridien" Hotel.
Tarragona, Spain.

G

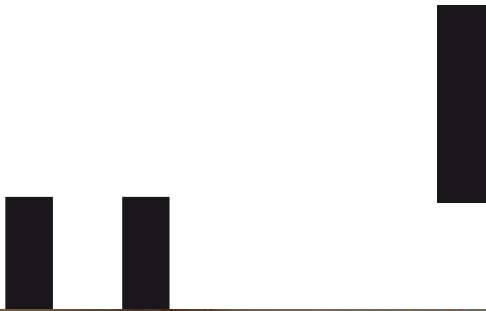

J

A

R



R

Guijarro is a family of three pebble-like lights, each one perfect for use on a wall or ceiling. This lamps were inspired by fine shingle: small, smooth and rounded pebbles whose individual shapes have been carved over many years by water and sand. A tiny wonder of nature, every pebble exhibits its own colour, contours and form.

With three different sizes and a choice of wood veneer finishes, the Guijarro lights are especially eye-catching when displayed in a group formation. Just as pebbles live in harmony, present a strong sense of oneness.

-
- GUIJARRO - SMALL, MEDIUM & LARGE
21 Natural Cherry, 24 Yellow & 29 Grey Wood Veneer.

O

SMALL

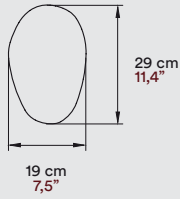

MEDIUM

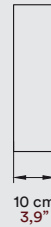
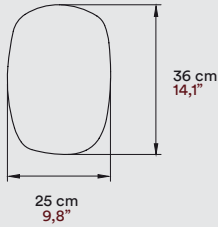

LARGE

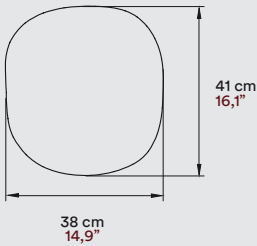

MATERIALS & COMPONENTS

Wood Veneer Shade

Acrylic Frontal Diffuser

Metal Back Plate

LIGHT SOURCE

120 - 277V

LED Integrated
Dimmable 0-10V
or

220 - 250V

Bulb GX53

Class I 

120 - 277V

LED Integrated
Dimmable 0-10V & TRIAC
or

120V









Bulb GX53

 US

ADA Compliant

FINISHES

WOOD VENEER

-  20 Ivory White
-  26 Red
-  21 Natural Cherry
-  28 Blue
-  22 Natural Beech
-  29 Grey
-  24 Yellow
-  33 Pale Rose
-  25 Orange
-  34 Sea Blue

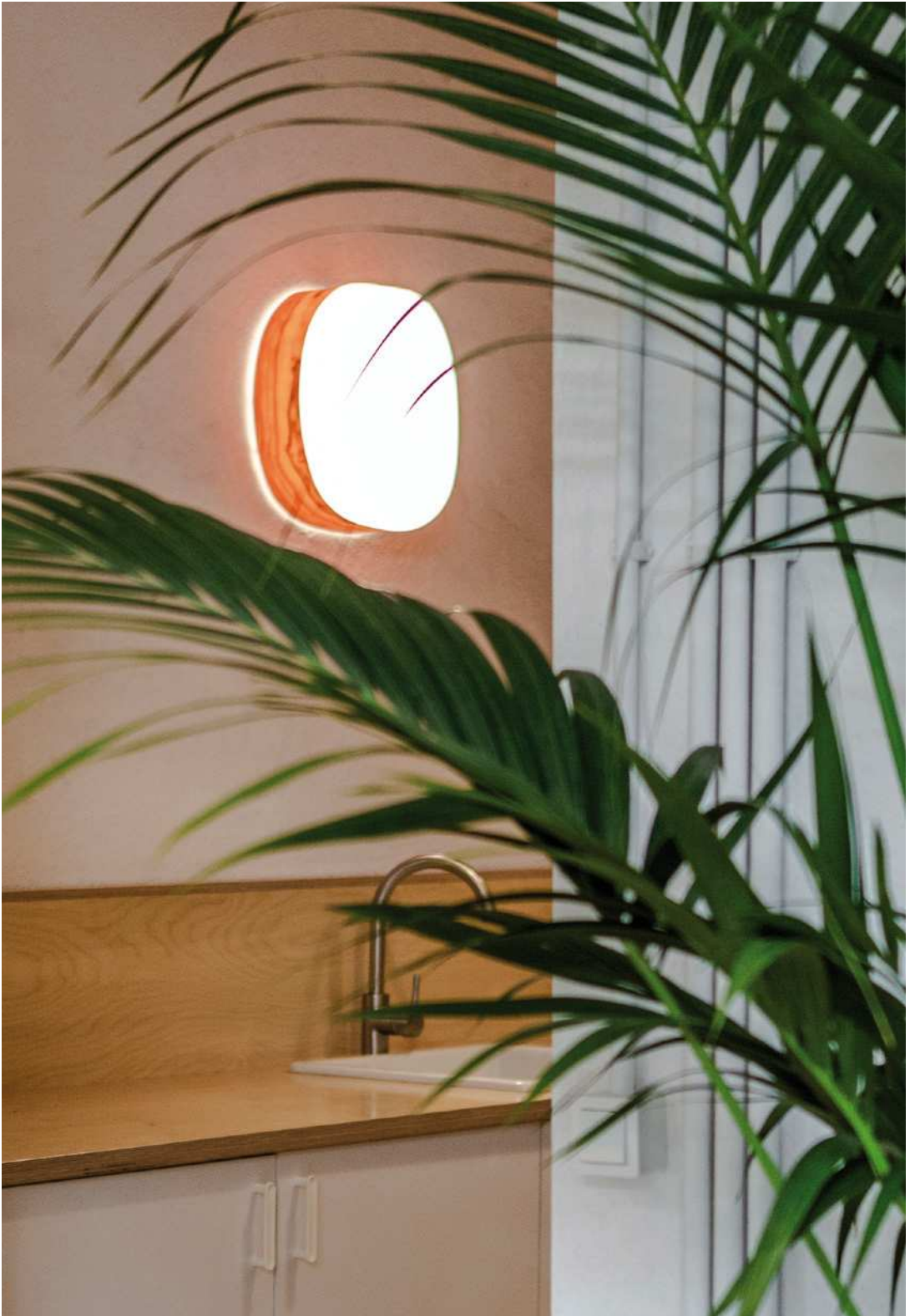

● GUIJARRO - LARGE WALL
21 Natural Cherry Wood Veneer. "Mad Mouse" Coworking. Valencia, Spain.



HI

COLLAR

Hi-Collar

Designed by:
Ray Power

Inspired by the traditional stiff shirt collar of old, Ray Power designed the Hi-Collar wall light. This small and simple lamp casts an indirect light in subdued tones both upwards and downwards, while the single piece of bent wood veneer diffuses a warming glow. There is no preening or primping, just a straightforward, minimalistic and unobtrusive light. It is a light perfectly suited to quiet spaces in homes and hotels, studios and eateries.

● **HI-COLLAR - WALL** | 20 Ivory White Wood Veneer. "Le Meridien" Hotel. Tarragona, Spain.



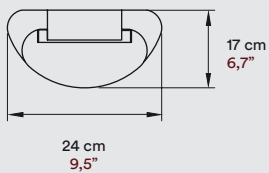

MATERIALS & COMPONENTS

Wood Veneer Shade

Metal Back Plate

LIGHT SOURCE

120 - 277V

LED Integrated
Dimmable 0-10V

Class I 







120 - 277V

LED Integrated
Dimmable 0-10V & TRIAC



FINISHES

WOOD VENEER

- | | | | |
|-------------------------------------------------------------------------------------|-------------------|-------------------------------------------------------------------------------------|--------------|
|  | 20 Ivory White |  | 26 Red |
|  | 21 Natural Cherry |  | 28 Blue |
|  | 22 Natural Beech |  | 29 Grey |
|  | 24 Yellow |  | 33 Pale Rose |
|  | 25 Orange |  | 34 Sea Blue |



● **HI-COLLAR - WALL** | 33 Pale Rose Wood Veneer.
"La Monella" Jewelers. Valencia, Spain.

I – CLUB

Designed by:
Burkhard Dämmer



I-CLUB SUSPENSION | 21 Natural Cherry Wood Veneer. "MSK Koch Center" Hospital, NY, USA. Photography: Chris Coober.

Created by Burkhard Dämmer, the I-Club is designed with clean architectural lines and a longer form that will illuminate its surroundings with understated elegance. An innovative lighting series, I-Club has a symmetrical beauty that is replicated across a number of models: suspension, wall, ceiling, floor and table.

I-Club

Suspension
Ceiling
Wall
Table



SHORT SLIM

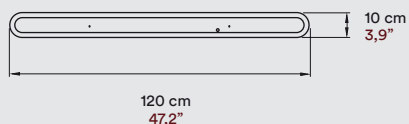
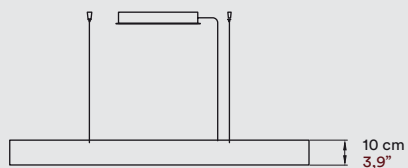

LONG SLIM

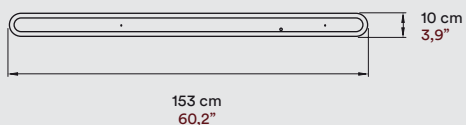
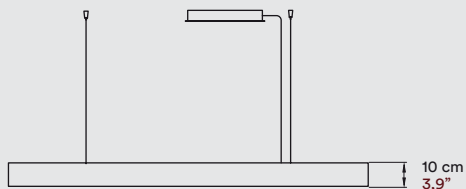

MATERIALS & COMPONENTS

Wood Veneer Shade

Top & Bottom Acrylic Diffuser

Metal Canopy

2 Steel Cables

2,5 m drop 8 ft drop

Electrical Cable

2,5 m drop 8 ft drop

FINISHES

WOOD VENEER

- | | | | |
|-------------------------------------------------------------------------------------|-------------------|-------------------------------------------------------------------------------------|--------------|
|  | 20 Ivory White |  | 26 Red |
|  | 21 Natural Cherry |  | 28 Blue |
|  | 22 Natural Beech |  | 29 Grey |
|  | 24 Yellow |  | 33 Pale Rose |
|  | 25 Orange |  | 34 Sea Blue |

LIGHT SOURCE

120 - 277V

LED Integrated

Dimmable 0-10V, Bluetooth or DALI

Class I **120 - 277V**

LED Integrated

Dimmable 0-10V & TRIAC





- **I-CLUB SLIM - SUSPENSION**
21 Natural Cherry Wood Veneer.
"Villa El Nido". Marbella, Spain.
Architects: A-cero Atchitects.

- **I-CLUB - TABLE**
21 Natural Cherry Wood Veneer.

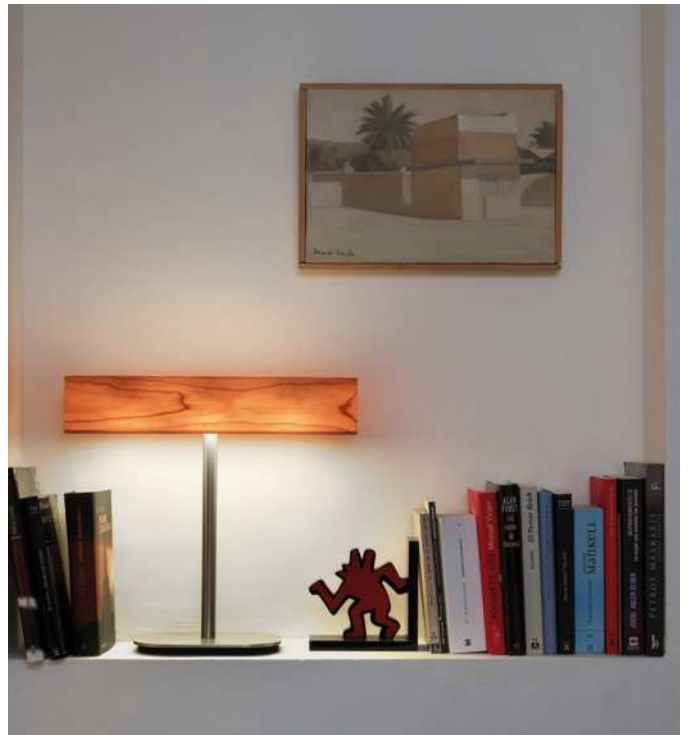

SMALL

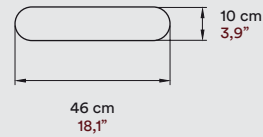
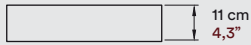

SLIM



MATERIALS & COMPONENTS

Wood Veneer Shade

Bottom & Upper Acrylic Diffuser

Metal Back Plate

LIGHT SOURCE

120 - 277V

LED Integrated
Dimmable 0-10V, Bluetooth or DALIClass I 

120 - 277V

LED Integrated
Dimmable 0-10V & TRIAC PENDING

ADA Compliant

FINISHES

WOOD VENEER

- | | | | |
|-------------------------------------------------------------------------------------|-------------------|-------------------------------------------------------------------------------------|--------------|
|  | 20 Ivory White |  | 26 Red |
|  | 21 Natural Cherry |  | 28 Blue |
|  | 22 Natural Beech |  | 29 Grey |
|  | 24 Yellow |  | 33 Pale Rose |
|  | 25 Orange |  | 34 Sea Blue |



-
- **I-CLUB - SMALL WALL**
21 Natural Cherry Wood Veneer.
"Caro" Hotel. Valencia, Spain.

-
- **I-CLUB SLIM - WALL**
21 Natural Cherry Wood Veneer.
"Palau de Casavells". Girona, Spain.

LARGE



MATERIALS & COMPONENTS

Wood Veneer Shade

Frontal Acrylic Diffuser

Metal Back Plate

LIGHT SOURCE

120 - 277V

LED Integrated

Dimmable 0-10V, Bluetooth or DALI

Class I

120 - 277V

LED Integrated

Dimmable 0-10V or TRIAC



FINISHES

WOOD VENEER

- 20 Ivory White
- 21 Natural Cherry
- 22 Natural Beech
- 24 Yellow
- 25 Orange
- 26 Red
- 28 Blue
- 29 Grey
- 33 Pale Rose
- 34 Sea Blue

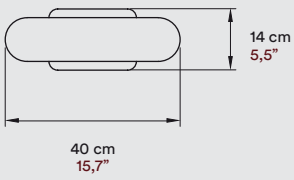
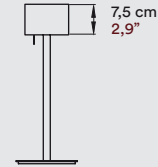
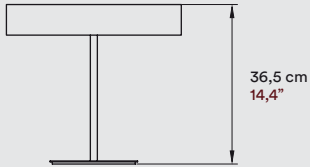

MATERIALS & COMPONENTS

Wood Veneer Shade

Bottom & Upper Acrylic Diffuser

Metal Stem & Base



Touch on/off Dimming Rod

Electrical Cable

145 cm 57"

LIGHT SOURCE

LED Integrated Dimmable











Class II  

LED Integrated Dimmable



FINISHES

WOOD VENEER

- | | | | |
|-------------------------------------------------------------------------------------|-------------------|-------------------------------------------------------------------------------------|--------------|
|  | 20 Ivory White |  | 26 Red |
|  | 21 Natural Cherry |  | 28 Blue |
|  | 22 Natural Beech |  | 29 Grey |
|  | 24 Yellow |  | 33 Pale Rose |
|  | 25 Orange |  | 34 Sea Blue |

LENS

Lens

Wall
Floor
Table

Designed by:
Mut Design



• **LENS**

33 Pale Rose Wood Veneer & Gold Metal Structure.

Designed by MUT, Lens enjoys flowing lines with no hard edges. Its wood veneer shade surrounds an oval circumference of light, and in its centre is a clear void. The shade is connected to a slender metallic base. Available as a table and floor lamp, Lens has two shade types: circular and elliptic. The elliptic version has two shapes: an elongated ellipse and a truncated ellipse.

Free from interruption, Lens's radiant light traces the air. Perfectly symmetrical and sleek, soothing and suave, Lens is one smooth luminaire.



● **LENS - FLOOR SUPER OVAL & OVAL**

21 Natural Cherry Wood Veneer & Matt Black Metal Structure. "Casa en la Huerta". Valencia, Spain. Architect: Ramón Esteve Estudio.



● **LENS - TABLE CIRCULAR**

20 Ivory White Wood Veneer & Gold Metal Structure.

"Bouet" Restaurant. Valencia, Spain. Architect: Ramón Esteve Estudio.



● **LENS - TABLE OVAL**

20 Ivory White Wood Veneer & Gold Metal Structure. "Casa en la Huerta". Valencia, Spain. Architect: Ramón Esteve Estudio.

FLOOR OVAL

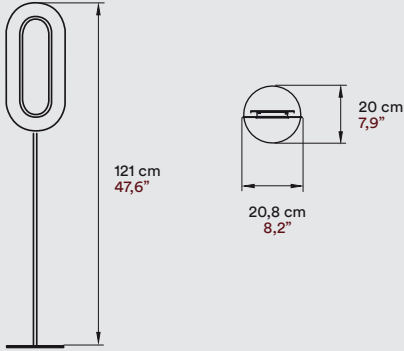

FLOOR SUPER OVAL

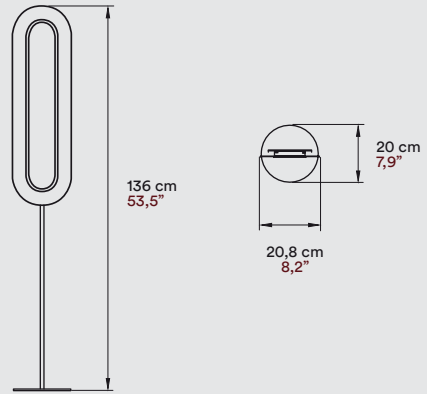

TABLE CIRCULAR

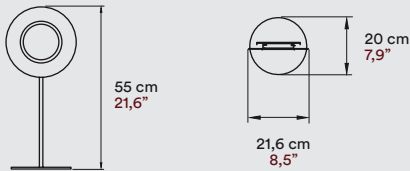
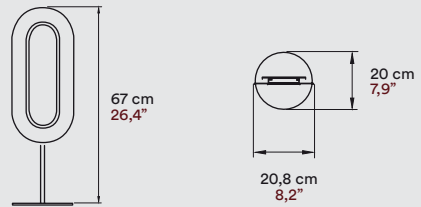

TABLE OVAL



MATERIALS & COMPONENTS

Wood Veneer Shade

Metal Ring, Stem & Base

Electrical Cable with Dimming Switch

FLOOR 185 cm 73"

TABLE 145 cm 57"

FINISHES

WOOD VENEER

- 20 Ivory White
- 28 Blue
- 21 Natural Cherry
- 29 Grey
- 22 Natural Beech
- 33 Pale Rose

LIGHT SOURCE

230V

LED Integrated Dimmable.

Class II

120V

LED Integrated Dimmable.

METAL

- IV-Matt Ivory
- NI-Matt Nickel
- BK-Matt Black
- GD-Gold

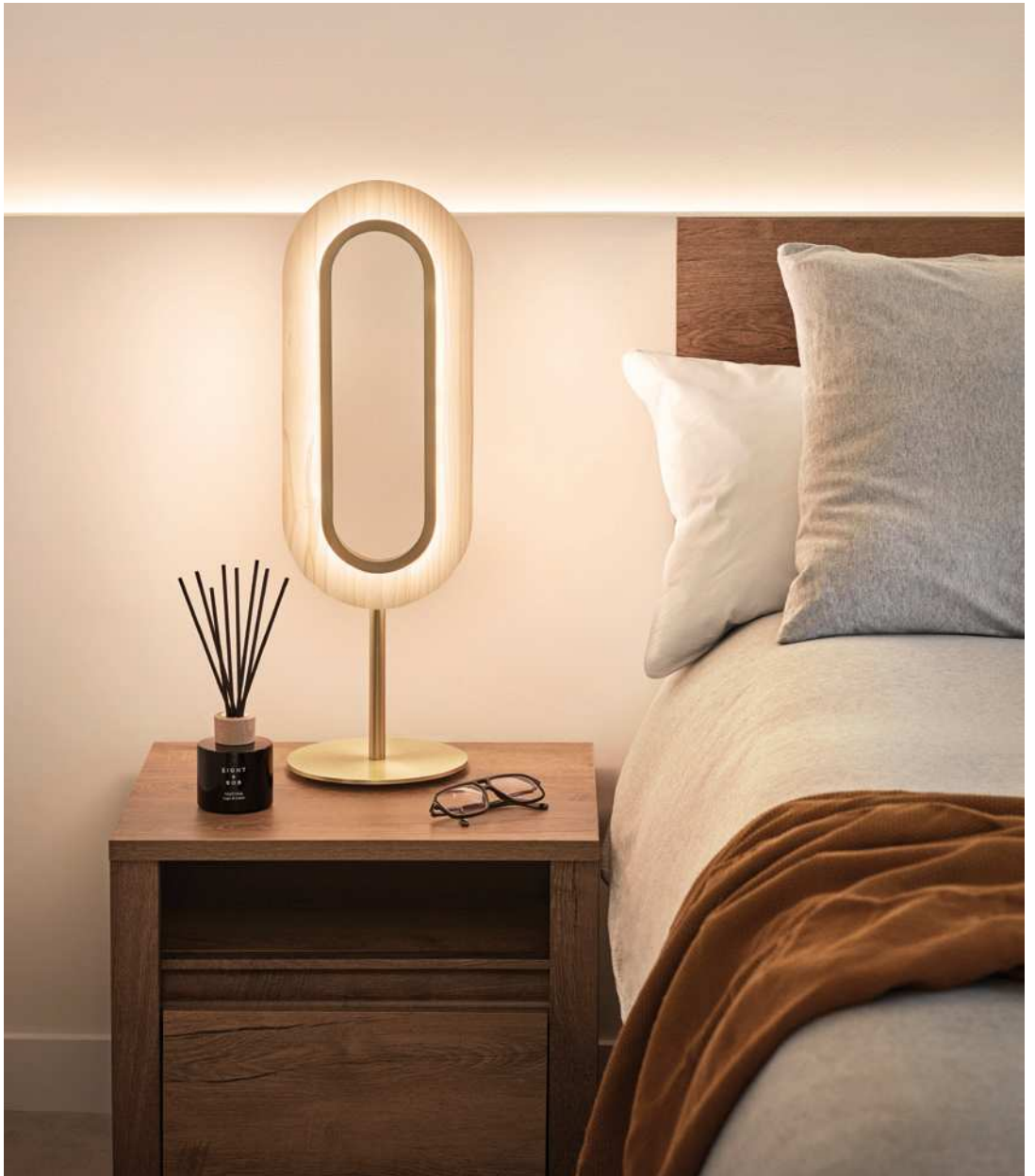

● **LENS - TABLE OVAL**

20 Ivory White Wood Veneer & Ivory White Metal Structure.

"Goded" Housing. Valencia, Spain. Project: Raw Arquitectura. Photography: Cualiti Photo Studio. Furniture: Annud.

L I



• **LINK - LARGE SUSPENSION**
21 Natural Cherry Wood Veneer.
"Bachelor loft", Toronto, Canada.
Design: Stephane Chamard.
Photographie by Lisa Petrole.



Link

Small Suspension
Large Suspension
Floor

Designed by:
Ray Power

Designed by Ray Power, Link appears exceptionally dashing in its stacked wood veneer Möbius strips. In mathematics, the Möbius strip is a surface with one continuous side, meaning the Link light is not only handsome, but discerning too.

With its billowy, cloud-like structure, Link is decidedly easy on the eye. Punctiliously crafted, the lamp's floating form is a clever illustration of wood's significant potential in lighting design. Link is available as a suspension lamp in three versions: small, large and modular. In addition, Link is an attractive floor lamp, its billowy mass poised on the top of a chrome tower-like base.

In Link, there is an obvious 'link' between brilliance and beauty, form and function.

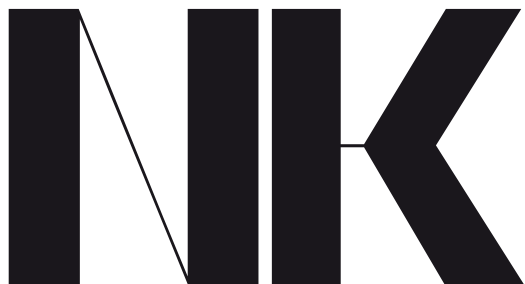

SMALL

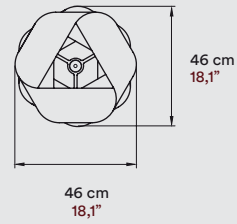
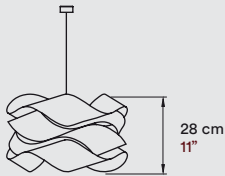

LARGE

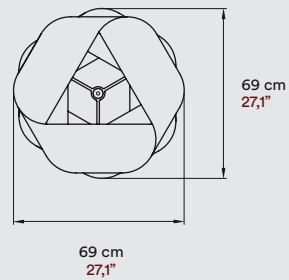
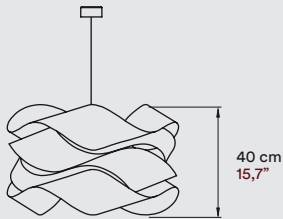

MATERIALS & COMPONENTS

Wood Veneer Shade

Metal Tripod & Canopy

Electrical Cable

2,5 m drop 8 ft drop

LIGHT SOURCE

220 - 250V

Bulb E27

Class I

120 - 277V

Bulb E26



AWARDS



DESIGN PLUS

Chicago

Frankfurt

FINISHES

WOOD VENEER

- | | | | |
|--|-------------------|--|--------------|
| | 20 Ivory White | | 26 Red |
| | 21 Natural Cherry | | 28 Blue |
| | 22 Natural Beech | | 29 Grey |
| | 24 Yellow | | 33 Pale Rose |
| | 25 Orange | | 34 Sea Blue |

METAL CANOPY

- | | | | |
|--|---------------|--|----------------|
| | BK-Matt Black | | NI-Matt Nickel |
| | WH-Matt White | | |



- **LINK - LARGE SUSPENSION**
20 Ivory White Wood Veneer.
"Ladon Restaurant", Spain.
Photography: estudi(H)ac.

- **LINK - LARGE SUSPENSION**
24 Yellow Wood Veneer.
Architects: Luca Construction and Design.
Inc Pennsylvania.

SMALL

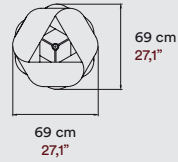
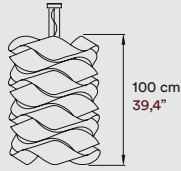

MEDIUM

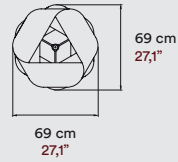
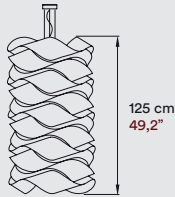

LARGE

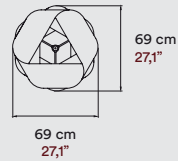
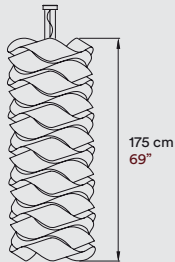

MATERIALS & COMPONENTS

Wood Veneer Shade

Metal Tripod & Canopy

3 Steel Cables
2,5 m drop 8 ft drop

Electrical Cable
2,5 m drop 8 ft drop

LIGHT SOURCE

220 - 250V
3, 4 or 6 Bulbs E27

Class I

120 - 277V
3, 4 or 6 Bulbs E26



FINISHES

WOOD VENEER

- 20 Ivory White
- 26 Red
- 21 Natural Cherry
- 28 Blue
- 22 Natural Beech
- 29 Grey
- 24 Yellow
- 33 Pale Rose
- 25 Orange
- 34 Sea Blue



- **LINK CHAIN LARGE - SUSPENSION**
20 Ivory White Wood Veneer.
HVB Freising Invest by Bottler & Luts Architekten BDA.
- **LINK CHAIN SMALL - SUSPENSION**
20 Ivory White Wood Veneer.
"Petit Palace" Hotel. Madrid, Spain. Architect: Jesús Ángel Miranda.



As the Link Chain is a modular system, it allows for different lengths and combination of Link shade modules upon request.

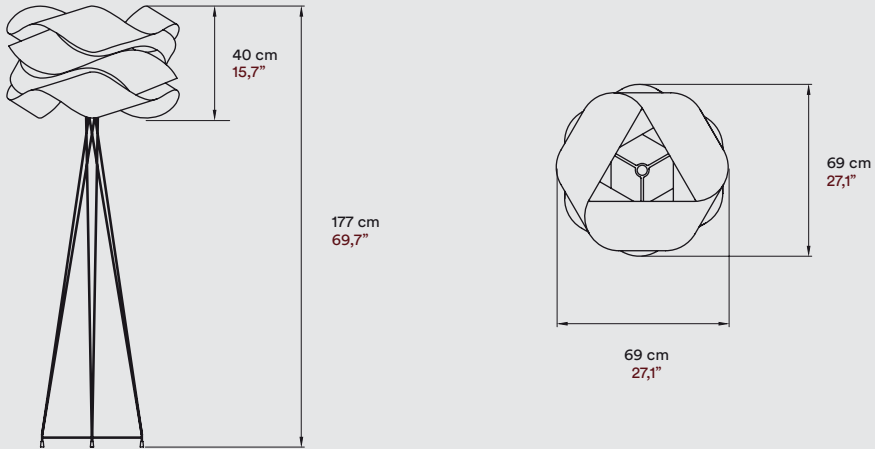

MATERIALS & COMPONENTS

Wood Veneer Shade

Metal Tripod & Base

Electrical Cable with Dimming Switch
185 cm 53"

LIGHT SOURCE

220 - 250V
Bulb E27

Class II 

120V
Bulb E26



FINISHES

WOOD VENEER

- | | |
|-------------------------------------------------------------------------------------------------------|--------------------------------------------------------------------------------------------------|
|  20 Ivory White |  26 Red |
|  21 Natural Cherry |  28 Blue |
|  22 Natural Beech |  29 Grey |
|  24 Yellow |  33 Pale Rose |
|  25 Orange |  34 Sea Blue |

METAL

-  NI-Matt Nickel

● **LINK - FLOOR**

21 Natural Cherry Wood Veneer.



● **LINK - FLOOR** | 24 Yellow Wood Veneer. "La Boscana" Restaurant. Spain. Architect: Jordi Font.

LO

Designed by:
Ray Power





Lola

Suspension

Floor

Table

Wall

Lola is the latest lamp for LZF designed by long-time collaborator Ray Power. Showcasing Power's ability to create imaginative three-dimensional forms, Lola is a conical lamp with an intricate geometric pattern. A veritable labour of love, Lola's shape went through many iterations, drawings and prototypes. The end result is, without doubt, a marvel of lighting design.

A particularly piquant Spanish name, Lola is very much alive, sensuous and intriguing. In a domestic or contract setting, Lola is a lamp that attracts and pleases the eye. Highly original and truly sophisticated, Lola's complex veneer construction is both accentuated and softened when illuminated. Available in a number of sizes and LZF's range of natural wood colours, Lola is stimulating, fascinating, arresting and sparkling: an especially piquant light.

• **LOLA MEDIUM SUSPENSION**

22 Natural Beech Wood Veneer.

"Palau de Casavells", Girona, Spain.



MEDIUM

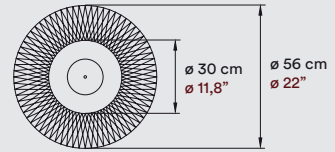
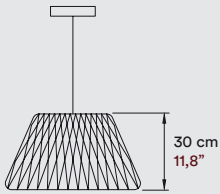

LARGE

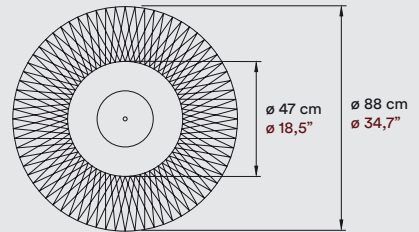
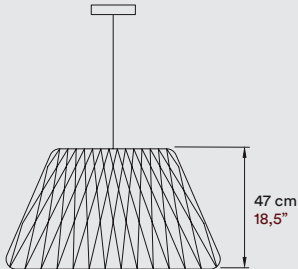

MATERIALS & COMPONENTS

Woven Wood Veneer Shade

Acrylic Frame

Metal Canopy

Electrical Cable

2,5 m drop 8 ft drop

LIGHT SOURCE

120 - 277V

LED Integrated

Dimmable 0-10V, Bluetooth or DALI

Class I 

120 - 277V

LED Integrated

Dimmable 0-10V & TRIAC



FINISHES

WOOD VENEER

 20 Ivory White

 29 Grey

 22 Natural Beech

METAL CANOPY

 BK-Matt Black

 NI-Matt Nickel

 WH-Matt White

- **LOLA - SUSPENSION**
22 Natural Beech Wood Veneer.



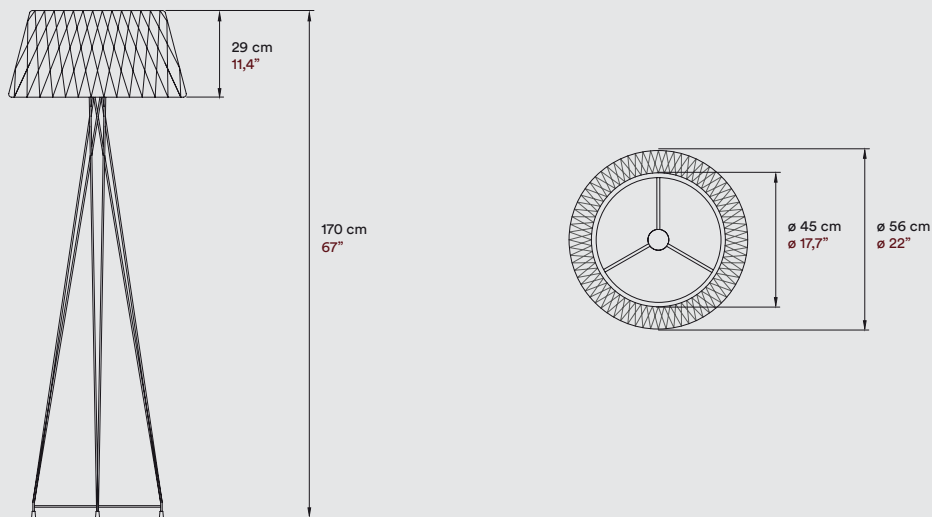

MATERIALS & COMPONENTS

Woven Wood Veneer Shade

Acrylic Frame

Metal Foot

Electrical Cable with Dimming Switch

185 cm 53"

LIGHT SOURCE

220 - 250V

Bulb E27

Class II  

120V

Bulb E26



160

FINISHES

WOOD VENEER

 20 Ivory White

 29 Grey

 22 Natural Beech

METAL

 IV-Matt Ivory

 NI-Matt Nickel

 BK-Matt Black

 GD-Gold

-
- **LOLA - FLOOR**
22 Natural Beech Wood Veneer.



-
- **LOLA - FLOOR**
20 Ivory White Wood Veneer & Matt Black Metal Foot. Photo: 4000k.
"Casa en la Huerta". Valencia, Spain. Architect: Ramón Esteve Estudio.

SMALL

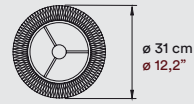
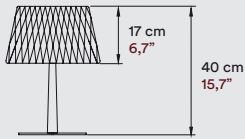

MEDIUM

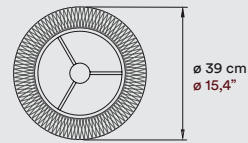
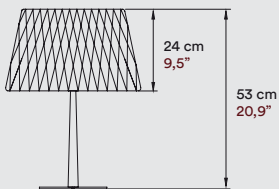

MATERIALS & COMPONENTS

Woven Wood Veneer Shade

Acrylic Frame

Metal or Marble Foot

Electrical Cable with Dimming Switch
145 cm 57"

LIGHT SOURCE

220 - 250V
Bulb E27



Class II  

120V
Bulb E26



FINISHES

WOOD VENEER

-  20 Ivory White
-  29 Grey
-  22 Natural Beech

METAL

-  IV-Matt Ivory
-  NI-Matt Nickel
-  BK-Matt Black
-  GD-Gold

● **LOLA - TABLE MEDIUM**

22 Natural Beech Wood Veneer & Matt Black Metal Foot.
"Casa en la Huerta". Valencia, Spain.
Architect: Ramón Esteve Estudio.



● **LOLA - TABLE MEDIUM**

20 Ivory White Wood Veneer &
Ivory White, Matt Black & Gold Metal.





● **LOLA LUX LARGE** | 20 Ivory White Wood Veneer & Black Marble Base. "Cosin" Workspace. Valencia, Spain.



MEDIUM LUX

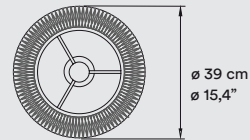
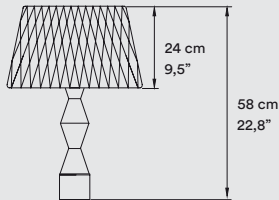

LARGE LUX

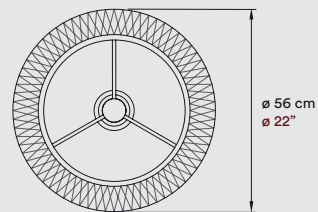
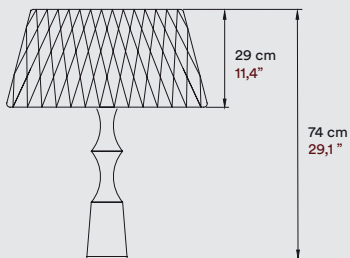

MATERIALS & COMPONENTS

Woven Wood Veneer Shade

Acrylic Frame

Marble Foot

Electrical Cable with Dimming Switch
145 cm 57"

LIGHT SOURCE

220 - 250V
Bulb E27



Class II  

120V
Bulb E26



FINISHES

WOOD VENEER

-  20 Ivory White
-  29 Grey
-  22 Natural Beech

MARBLE LOLA LARGE LUX

-  Black "Marquina" Marble



● **LOLA LUX MEDIUM** | 20 Ivory White Wood Veneer & Black Marble Base. "Caro Hotel". Valencia, Spain.

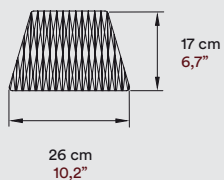

MATERIALS & COMPONENTS

Woven Wood Veneer Shade

Acrylic Frame

Metal Back Plate

LIGHT SOURCE

220 - 250V
2 Bulbs GX53

Class I 

120 - 277V
2 Bulbs GX53



ADA Compliant

FINISHES

WOOD VENEER

 20 Ivory White

 22 Natural Beech



● LOLA - WALL | 22 Natural Beech Wood Veneer. "Caro" Hotel. Valencia, Spain.

M

M

I

I

N

K

I

A



MiniMikado

Designed by:
Miguel Herranz

- **MINIMIKADO- SUSPENSION**
24 Yellow Wood Veneer. "Villa El Nido". Marbella, Spain.

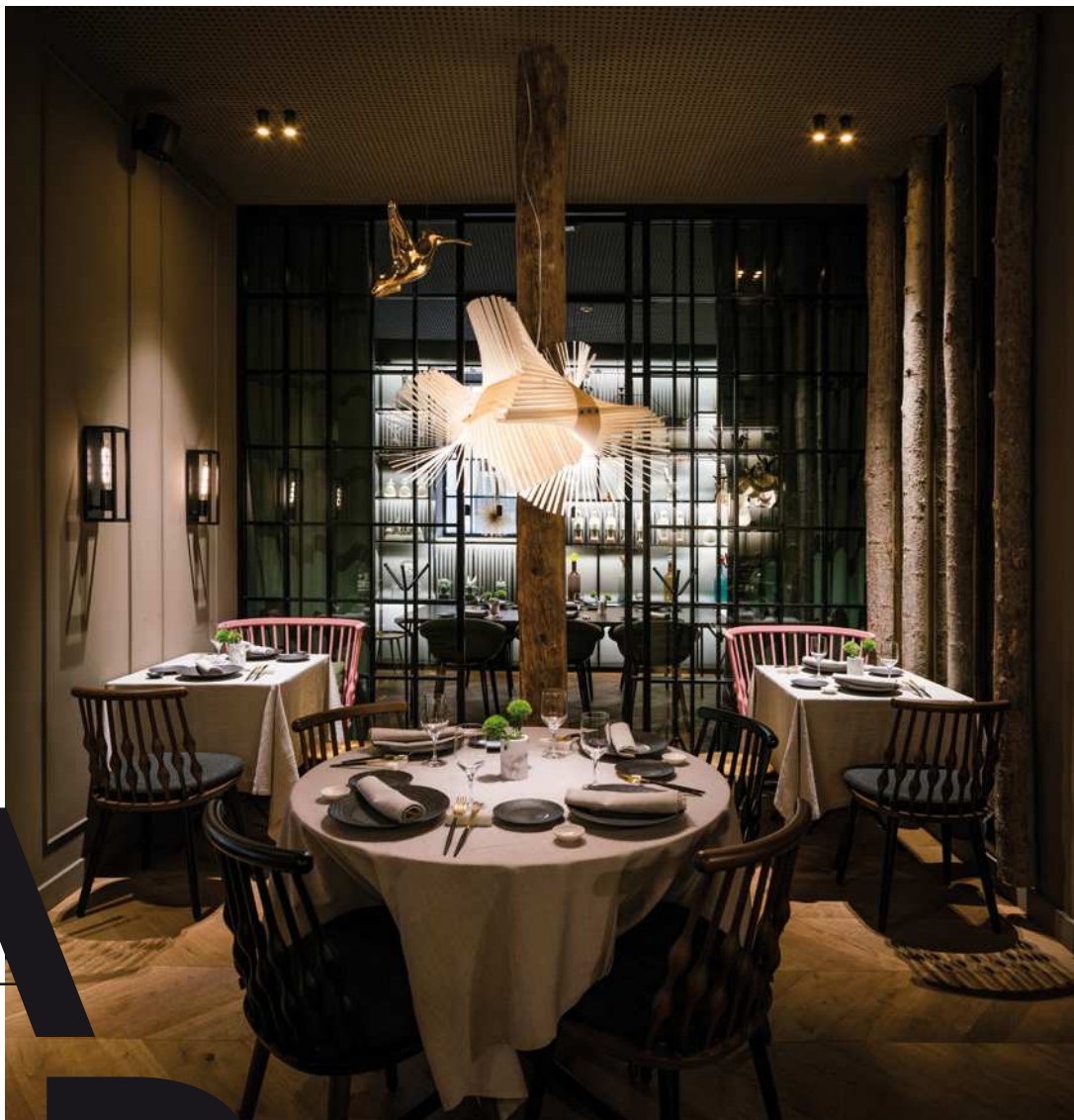

M A D I D O

The Mikado light takes its names from the classic pick-up-sticks game, where sticks are bundled together and when released, fall in a circular jumble. A radiant light, Mikado's wood veneer strips spread outwards, in a manner evocative of a bird's plumage. Cleverly engineered, the Mikado's form is both chaotic and harmonious at the same time.

Designed by Miguel Herranz, the Mikado is a free spirit, possessing an air of nonchalance and a teasingly impish swagger. It is a light whose profile is like a coruscating kaleidoscope of pattern.

- **MINIMIKADO - SUSPENSION**
20 Ivory White Wood Veneer. "Alameda" Restaurant. Madrid, Spain.



- **MINIMIKADO - SUSPENSION**
22 Natural Beech Wood Veneer.



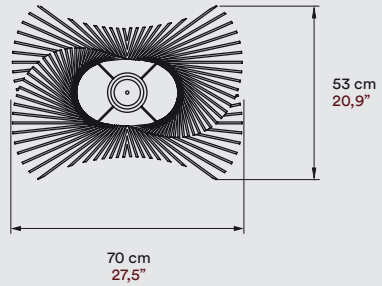
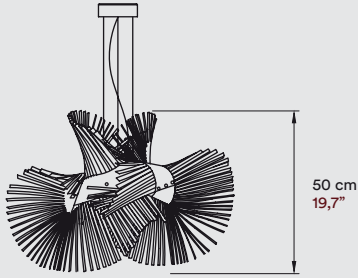

MATERIALS & COMPONENTS

Wood Veneer Shade

Metal Structure & Canopy

3 Steel Cables

2,5 m drop 8 ft drop

Electrical Cable

2,5 m drop 8 ft drop

LIGHT SOURCE

220 - 250V

Bulb E27

Class I CE

120 - 277V

Bulb E26



FINISHES

WOOD VENEER

- 20 Ivory White
- 26 Red
- 21 Natural Cherry
- 28 Blue
- 22 Natural Beech
- 29 Grey
- 24 Yellow
- 33 Pale Rose
- 25 Orange
- 34 Sea Blue

AWARDS



Chicago

DESIGN PLUS

Frankfurt

● MINIMIKADO - SUSPENSION

22 Natural Beech Wood Veneer.
"Caro" Hotel. Valencia, Spain.

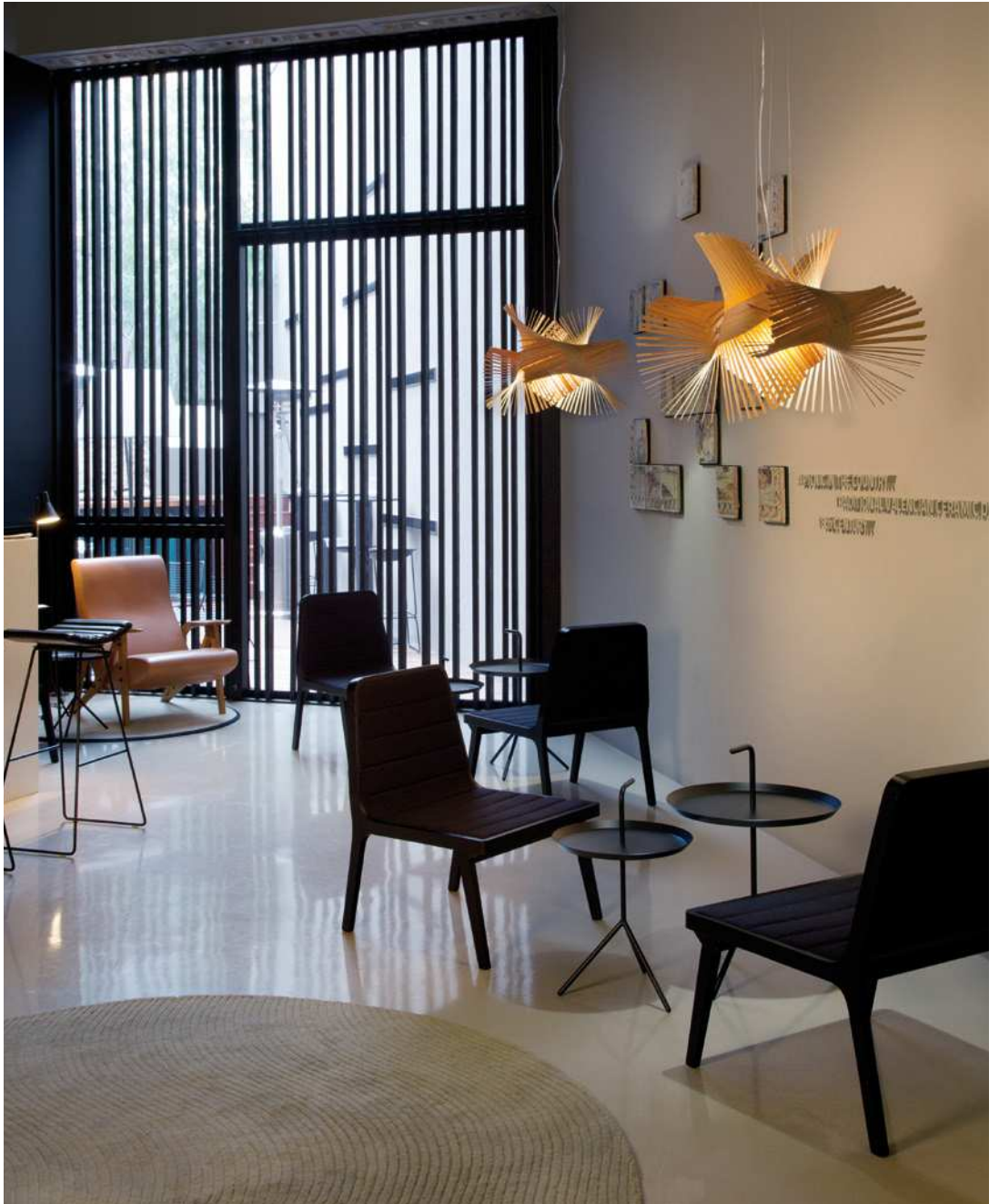

NEW



New Wave

- **NEW WAVE - SUSPENSION**
28 Blue & 24 Yellow Wood Veneer.
"Ma Khin" Cafe. Valencia, Spain.



Designed by:
Ray Power

New Wave comprises of two interlocking interior and exterior wood veneer sheets. Differing in colour to the exterior sheets, the interior sheets's edge juts out, creating a clever design feature that enhances the New Wave's profile. The resulting composition is well-proportioned and fluid, giving the New Wave a smooth, free-flowing countenance.

NEW WAVE

LED

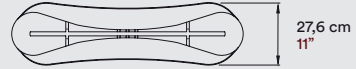
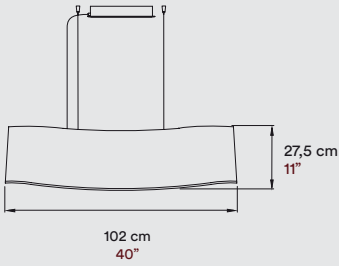

BULBS

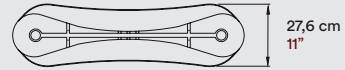
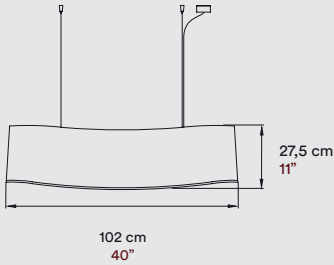

MATERIALS & COMPONENTS

Wood Veneer Shade

Metal Structure & Canopy

4 Steel Cables

2,5 m drop 8 ft drop

Electrical Cable

2,5 m drop 8 ft drop

FINISHES

WOOD VENEER COMBINATIONS

Exterior

Interior



21 Cherry

with



20 Ivory White



26 Red

with



24 Yellow



28 Blue

with



24 Yellow

LIGHT SOURCE

120 - 277V

LED Integrated

Dimmable 0-10V, Bluetooth or DALI

or

220 - 250V

2 Bulbs E27

Class I

AWARDS



Chicago

120 - 277V

LED Integrated

Dimmable 0-10V & TRIAC

or

120 - 277V

2 Bulbs E26





- **NEW WAVE - SUSPENSION**

21 Natural Cherry & 20 Ivory White Wood Veneer.

- **NEW WAVE - SUSPENSION**

26 Red & 20 Yellow Wood Veneer.

Private Company Office. Madrid, Spain.



- **NEW WAVE - SUSPENSION**

28 Blue & 24 Yellow Wood Veneer.



Nut

Designed by:
Ray Power

Nut is an unfussy and modest knot of light, its elegant form made by the twisting and looping of wood veneer. A small and simple pendant, the Nut lamp is ideal when seeking to achieve a relaxed ambience.

The Nut lamp has two different forms, as determined by the direction of torsion—that is to say, the way in which the wood veneer is twisted.



● **NUT - SUSPENSION**

22 Natural Beech Wood Veneer.

"Malangen Retreat". Architects: Snorre Stinessen Arkitektur Norway.

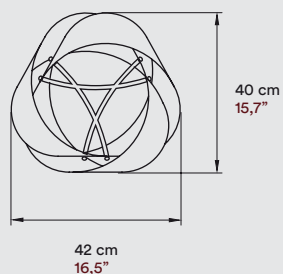
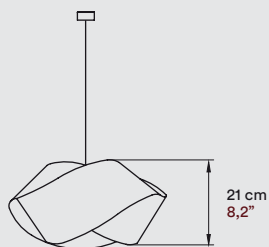

MATERIALS & COMPONENTS

Wood Veneer Shade

Metal Tripod & Canopy

Electrical Cable

2,5 m drop 8 ft drop

LIGHT SOURCE

220 - 250V

Bulb E27

Class I 

120 - 277V

Bulb E26



 US

FINISHES

WOOD VENEER

- | | | | |
|-------------------------------------------------------------------------------------|-------------------|-------------------------------------------------------------------------------------|--------------|
|  | 20 Ivory White |  | 26 Red |
|  | 21 Natural Cherry |  | 28 Blue |
|  | 22 Natural Beech |  | 29 Grey |
|  | 24 Yellow |  | 33 Pale Rose |
|  | 25 Orange |  | 34 Sea Blue |

METAL CANOPY

- | | | | |
|-------------------------------------------------------------------------------------|---------------|-------------------------------------------------------------------------------------|----------------|
|  | BK-Matt Black |  | NI-Matt Nickel |
|  | WH-Matt White | | |

● **NUT - SUSPENSION**

20 Ivory White Wood Veneer.
"Villa El Nido". Marbella, Spain.
Architects: A-cero Atchitects.



O

R

B

Orbit

Designed by:
Miguel Herranz

With its thoughtful air, the ovalesque Orbit light will decorate any wall with quiet self-assurance. Created by Spanish designer Miguel Herranz, Orbit is an unfussy lamp whose shape is handmade by twisting a piece of wood veneer. Two designs are feasible, depending on the direction of torsion—that is how the wood veneer is twisted.

Light from the Orbit is diffused both upwards and downwards via its two apertures and an inner glow radiates outwards, accentuating the beauty of the timber veneer grain. In essence, just as the earth is in orbit around the sun, light is in orbit around the Orbit.

● **ORBIT - WALL** | 20 Ivory White Wood Veneer. "Caro" Hotel. Valencia, Spain.





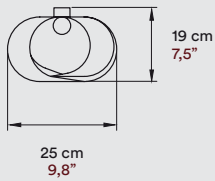
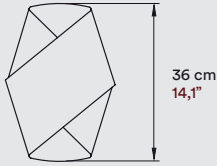

MATERIALS & COMPONENTS

Wood Veneer Shade

Metal Back Plate

LIGHT SOURCE

220 - 250V
Bulb E27

Class I

120 - 277V
Bulb E26

FINISHES

WOOD VENEER

- 20 Ivory White
- 26 Red
- 21 Natural Cherry
- 28 Blue
- 22 Natural Beech
- 29 Grey
- 24 Yellow
- 33 Pale Rose
- 25 Orange
- 34 Sea Blue



● **ORBIT - WALL**
20 Ivory White Wood Veneer.
"Caro" Hotel. Valencia, Spain.

OSPLE WE L M

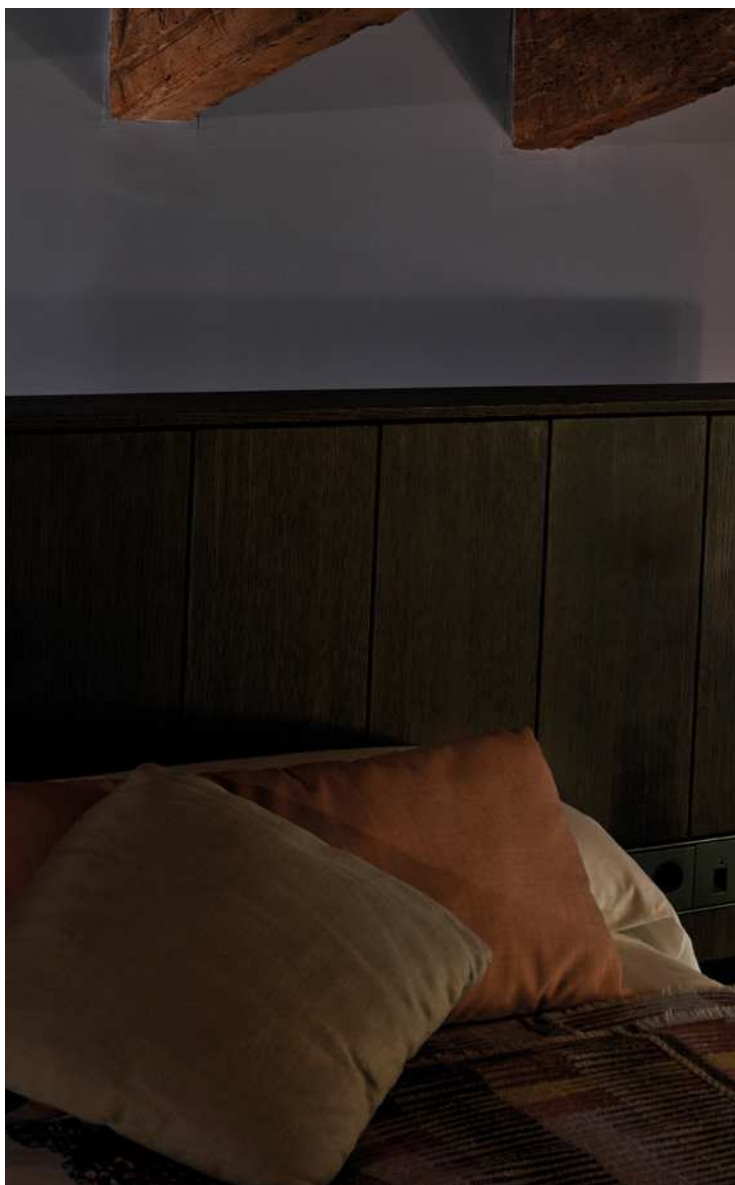

PLEG



Pleg

Designed by:
Yonoh Creative Studio

The Pleg wall light resembles a folded sheet of paper, putting one in mind of a decorative piece of origami. Designed by Yonoh Creative Studio, Pleg is perfect for cosy spaces, bedsides and alcoves, owing to its small size.

Pleg can be installed in four different positions, with light diffused horizontally or vertically from its open sides. At the same time, light emanates warmly through the attractive bent wood veneer. Straightforward, smart and subtle, the Pleg light is modest and charming.

- **PLEG - WALL**
20 Ivory White Wood Veneer.
"Caro" Hotel. Valencia, Spain.

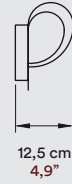
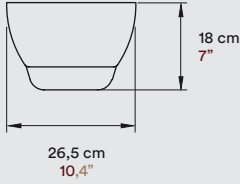

MATERIALS & COMPONENTS

Wood Veneer Shade

Acrylic Side Diffuser

Metal Back Plate

LIGHT SOURCE

120 - 277V

LED Integrated
Dimmable 0-10V
or

220 - 250V

Bulb GX53

Class I

120 - 277V

LED Integrated
Dimmable 0-10V & TRIAC
or

120V

Bulb GX53



FINISHES

WOOD VENEER

- 20 Ivory White
- 26 Red
- 21 Natural Cherry
- 28 Blue
- 22 Natural Beech
- 29 Grey
- 24 Yellow
- 33 Pale Rose
- 25 Orange
- 34 Sea Blue

AWARDS



Chicago



reddot design award
Germany



● **PLEG - WALL**
33 Pale Rose Wood Veneer.
"La Monella" Jewellers.
Valencia, Spain.

POD &

Medium

Designed by:
Burkhard Dämmer

Kin to the Poppy pendant, Pod is a vertically elongated and ellipse-like orbit of light whose body is made up of a repeated series of wood veneer strips. Different from the Poppy, a small gap between each strip on the Pod allows just a peek at the light within.

The Pod is appreciably unostentatious, having a fresh manner that smiles and illuminates its surroundings with an altruistic sense of cool. It is a pendant that works well discretely or as part of a striking cluster of Pod and Poppy lights.



● **POD & POPPY - SUSPENSION** | 24 Yellow Wood Veneer. "Lucky Apple" Restaurant. Netherlands. Architect: Art2Go Interieurprojecten.

POPPY

Small
Medium

Kin to the Pod pendant, the slightly squat and spherical Poppy lamp is made up of a repeated series of wood veneer strips. Different from the Pod, a larger gap between each strip on the Poppy emits light with a greater luminosity, its mature form sparkling in full bloom.

Compared to the Pod pendant, Poppy is like the mature older sibling, with a fully developed form that lends weight to its mellow disposition. Both the Poppy and Pod lamps work well in unison, able to form impressive cloud-like clusters.



POPPY SMALL

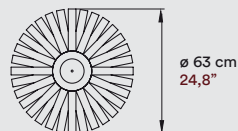
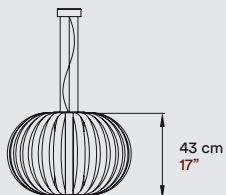

POPPY MEDIUM

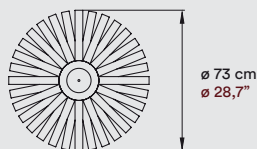
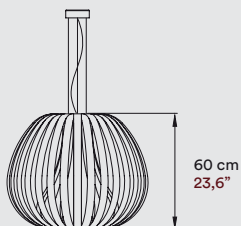

POD MEDIUM

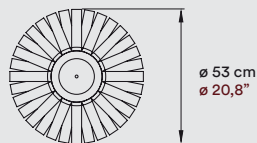
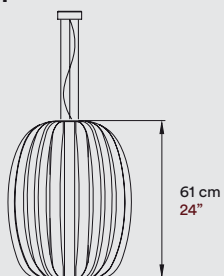

MATERIALS & COMPONENTS

Wood Veneer Shade

Metal Canopy

3 Steel Cables

2,5 m drop 8 ft drop

Electrical Cable

2,5 m drop 8 ft drop

LIGHT SOURCE

220 - 250V

Bulb E27

Class I 

120 - 277V

Bulb E26



FINISHES

WOOD VENEER

- | | | | |
|-------------------------------------------------------------------------------------|-------------------|-------------------------------------------------------------------------------------|--------------|
|  | 20 Ivory White |  | 26 Red |
|  | 21 Natural Cherry |  | 28 Blue |
|  | 22 Natural Beech |  | 29 Grey |
|  | 24 Yellow |  | 33 Pale Rose |
|  | 25 Orange |  | 34 Sea Blue |



● **POD - MEDIUM SUSPENSION** | 20 Ivory White Wood Veneer. "Alameda" Restaurant. Madrid, Spain.

RAIN D R O P

Raindrop

Small
Medium

Designed by:
Javier Herrero Studio

Visualise the simple beauty of a stationary raindrop, a small and glistening droplet that instead of falling, remains in a state of suspended animation. While Tina couldn't stand the rain against her window, the Raindrop pendant is a welcome sight.

Javier Herrero imagined and designed the Raindrop pendant, its suspended shade made using strips of wood veneer that contain a glowing ball. Available in small and medium sizes, the Raindrop's form is playful and poised. It is a light that will hang gracefully by itself and is especially pleasing and engaging when arranged in a group formation.

● RAINDROP - MEDIUM SUSPENSION | 20 Ivory White Wood Veneer.



SMALL

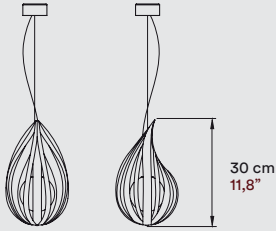

MEDIUM

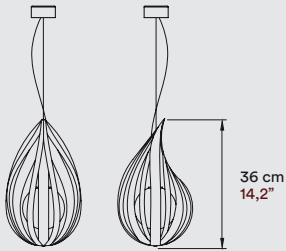

MATERIALS & COMPONENTS

Wood Veneer Shade

Frosted Glass Ball

Metal Canopy

Electrical Cable

2,5 m drop 8 ft drop

Steel Cable

2,5 m drop 8 ft drop

FINISHES

WOOD VENEER

- 20 Ivory White
- 26 Red
- 21 Natural Cherry
- 28 Blue
- 22 Natural Beech
- 29 Grey
- 24 Yellow
- 33 Pale Rose
- 25 Orange
- 34 Sea Blue

LIGHT SOURCE

220 - 250V

Bulb G9

Class I

120V

Bulb G9





- **RAINDROP**
SMALL SUSPENSION
21 Natural Cherry
Wood Veneer.



- **RAINDROP - MEDIUM**
SUSPENSION
21 Natural Cherry
Wood Veneer.

SATURINIA



The Saturnia pendant is reminiscent of Saturn's system of planetary rings. A truly handsome and enchanting light, its form is one that captivates the eye: similar to the way in which we gaze wondrously at stars in the night sky.

Saturnia balances both indirect and direct lighting with aplomb. Its circular wood veneer spreads warm light outwards, while its Plexiglas diffuser provides the perfect direct light necessary for task-oriented jobs and for social or work environments. Saturnia makes a bold statement as a solo light or when suspended in a group of varied sizes.

Small
Medium
Large

Designed by:
Oskar Cerezo



● **SATURNIA**
MEDIUM SUSPENSION
21 Natural Cherry Wood Veneer. "BNP Paribas Investment Partners".
Architects: Fokkema and Partners Architecten
Amsterdam.

SMALL

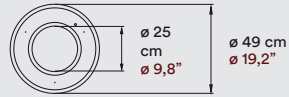
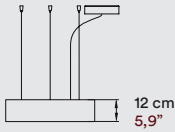

MEDIUM

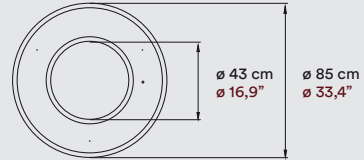
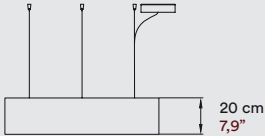

LARGE

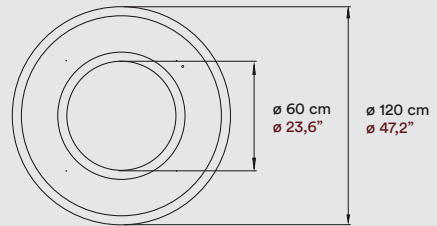
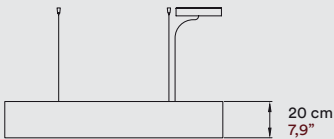

MATERIALS & COMPONENTS

Wood Veneer Shade

Top & Bottom Acrylic Diffuser

Metal Canopy

3 Steel Cables SMALL & MEDIUM

4 Steel Cables LARGE

2,5 m drop 8 ft drop

Electrical Cable

2,5 m drop 8 ft drop

FINISHES

WOOD VENEER

- 20 Ivory White
- 26 Red
- 21 Natural Cherry
- 28 Blue
- 22 Natural Beech
- 29 Grey
- 24 Yellow
- 33 Pale Rose
- 25 Orange
- 34 Sea Blue

LIGHT SOURCE

120 - 277V

LED Integrated

Dimmable 0-10V, Bluetooth or DALI

Class I

120 - 277V

LED Integrated

Dimmable 0-10V & TRIAC





● SATURNIA - LARGE SUSPENSION | 34 SeaBlue Wood Vener. Boardroom, private company, Netherlands.

SPIRO

Spiro

Medium
Large

Designed by:
Remedios Simón

Op art (optical art) developed in the 1960s as an artistic style that used geometric shapes to generate optical illusions. With a nod to the genre, designer Remedios Simón created Spiro, a charismatic pendant whose frame contains a mass of irregular wood veneer spirals.

Available in 3 outer shell options (cherrywood or acrylic white or wblack), Spiro is an impressive light with an enchanting aura. Similar to op art, Spiro plays with the physiology and psychology of human perception, its charm utterly irresistible.

● SPIRO - LARGE SUSPENSION

Matt White Outer Shell & 22 Natural Beech Wood Veneer.
"MSK Koch Center" Hospital, NY, USA. Photography: Chris Cooper.









MEDIUM

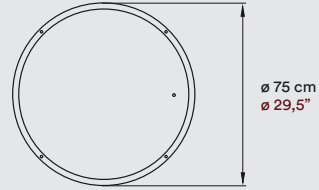
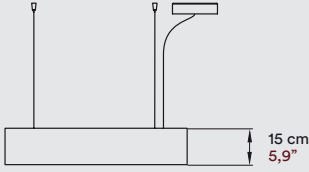

LARGE

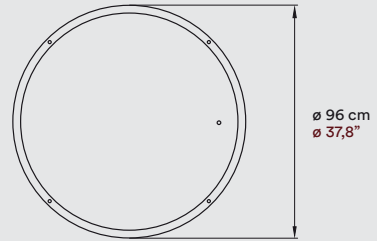
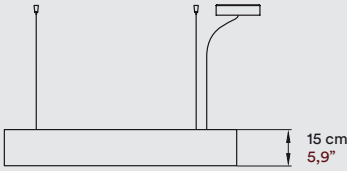

MATERIALS & COMPONENTS

Opaque Wood or Acrylic Outer Shell

Wood Veneer Spirals

Top & Bottom Diffuser

Metal Canopy

4 Steel Cables
2,5 m drop 8 ft drop

Electrical Cable
2,5 m drop 8 ft drop

LIGHT SOURCE

120 - 277V
LED Integrated
Dimmable 0-10V, Bluetooth or DALI



120 - 277V
LED Integrated
Dimmable 0-10V & TRIAC



AWARDS

HD Las Vegas. Product Design Competition. USA

FINISHES

WOOD SHELL

21 Natural Cherry

ACRYLIC SHELL

Black

White

WOOD VENEER SPIRALS WITH WOOD SHELL

21 Natural Cherry

WOOD VENEER SPIRALS WITH ACRYLIC SHELL

20 Ivory White 26 Red

21 Natural Cherry 28 Blue

22 Natural Beech 29 Grey

24 Yellow 33 Pale Rose

25 Orange 34 Sea Blue

METAL CANOPY

BK-Matt Black

WH-Matt White

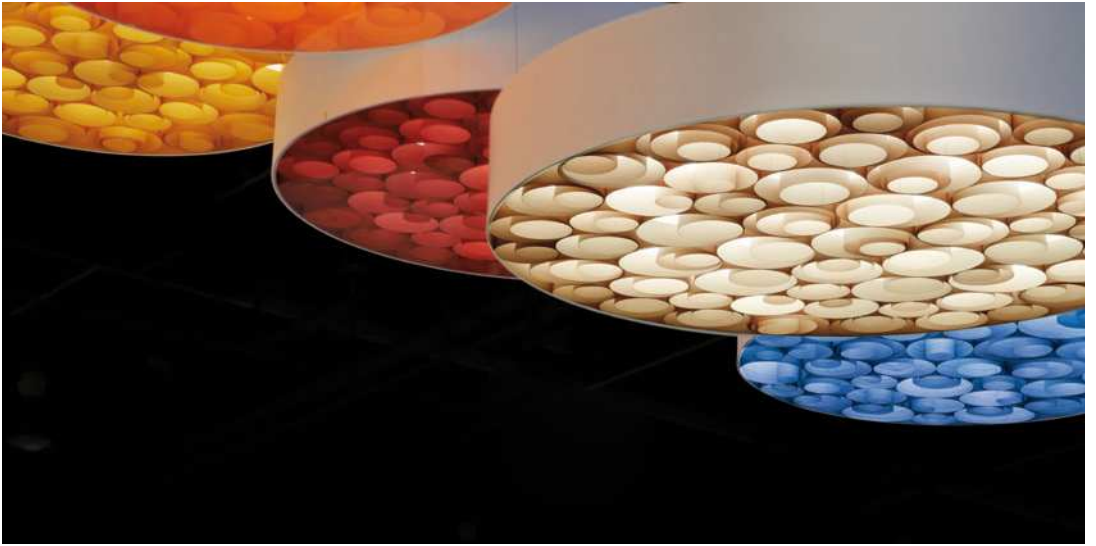

● **SPIRO - LARGE SUSPENSION**

White Outer Shell & 24 Yellow, 25 Orange, 26 Red, 22 Natural Beech & 28 Blue Wood Veneer.



● **SPIRO - LARGE SUSPENSION**

Matt Black Outer Shell & 21 Natural Cherry Wood Veneer.
"Villa El Nido". Marbella, Spain. Architects: A-cero Architects.

STITCHES

Stitches

Bamako
Tombuctú

Designed by:
Burojet

Created by Egbert-Jan Lam of Netherlands-based Burojet Design Studio, Stitches is a family of four well-hemmed pendants: Tombuctú and Bamako. Each light is named after a city or town in Mali, West Africa. Mali has a long history as a producer of embroidery, its many skilled artisans-found throughout Tombuctú and Bamako-adept at needlework.

The Stitches pendants impart an appealing bohemian air, their warm wood veneer panels embroidered with peeping threads of light. Crafted with passion and precision, Tombuctú and Bamako hint at the simple beauty found in Malian embroidery.

● **STITCHES BAMAKO - SUSPENSION**

24 Yellow Wood Veneer.

"Jaleo Disney Springs" Hotel. Washington DC.

Architect: Juli Capella. Chef: José Andrés.



BAMAKO

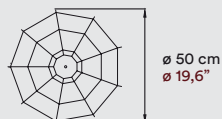
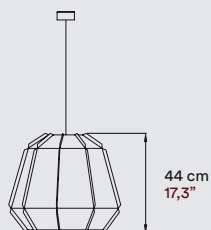

TOMBUCTÚ

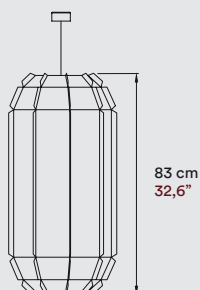

MATERIALS & COMPONENTS

Wood Veneer Shade

Metal Canopy

Steel Cable

8 ft drop. Only for USA & Canada

Electrical Cable

2,5 m drop 8 ft drop

LIGHT SOURCE

220 - 250V

Bulb E27

Class I 

120 - 277V

Bulb E26



FINISHES

WOOD VENEER

- | | | | |
|-------------------------------------------------------------------------------------|----------------|-------------------------------------------------------------------------------------|--------------|
|  | 20 Ivory White |  | 28 Blue |
|  | 24 Yellow |  | 29 Grey |
|  | 25 Orange |  | 33 Pale Rose |
|  | 26 Red |  | 34 Sea Blue |

AWARDS



Chicago



Germany



● **STITCHES TOMBUCTÚ - SUSPENSION**

20 Ivory White Wood Veneer. "Palau de Casavells". Girona, Spain.

A large, bold, black letter 'S' is positioned in the upper left quadrant of the page.A large, bold, black letter 'R' is positioned in the upper right quadrant of the page.A large, bold, black letter 'W' is positioned in the center of the page.

Swirl

Small
Large

Designed by:
Ray Power

Swirl excites the eye with its eddying and whirling folds, their twisting twirl a sensuous feat. Designed by Ray Power, Swirl is an accomplished pendant, its form thoughtfully considered and sculptured. Power's designs are typically based on geometry and his predilection for creating three-dimensional forms from flat materials (wood veneer). Swirl is no exception, its precise contours brought to life in stereo.

With a soulful character and presence, the Swirl lamp will vibe well with any interior. When a light is striking from every angle, one might expect more than a hint of conceit. And yet Swirl is wholly modest, its beauty inspiring and uplifting.

The Swirl pendant was accorded a Special Mention by the German Design Council.

● **SWIRL - SMALL SUSPENSION**

20 Ivory White Wood Veneer. Apartment. Manresa, Spain. Project: DüeM Estudio. Photography: Davide Pellegrini.



SMALL

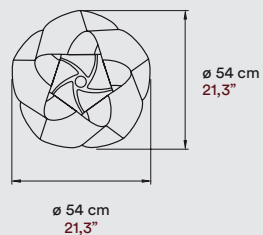
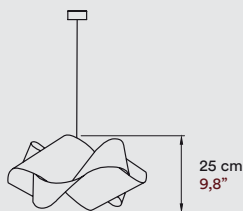

LARGE

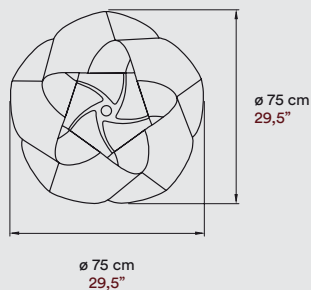
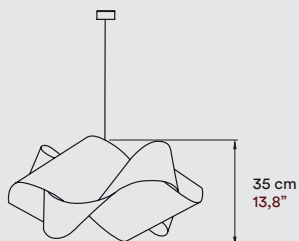

MATERIALS & COMPONENTS

Wood Veneer Shade

Metal Tripod & Canopy

Electrical Cable

2,5 m drop 8 ft drop

LIGHT SOURCE

220 - 250V

Bulb E27

Class I 

120 - 277V

Bulb E26



AWARDS



Chicago





Germany

FINISHES

WOOD VENEER

- | | | | |
|-------------------------------------------------------------------------------------|-------------------|-------------------------------------------------------------------------------------|--------------|
|  | 20 Ivory White |  | 26 Red |
|  | 21 Natural Cherry |  | 28 Blue |
|  | 22 Natural Beech |  | 29 Grey |
|  | 24 Yellow |  | 33 Pale Rose |
|  | 25 Orange |  | 34 Sea Blue |

METAL CANOPY

- | | | | |
|-------------------------------------------------------------------------------------|---------------|-------------------------------------------------------------------------------------|----------------|
|  | BK-Matt Black |  | NI-Matt Nickel |
|  | WH-Matt White | | |

-
- **SWIRL - SMALL SUSPENSION**
26 Red Wood Veneer.

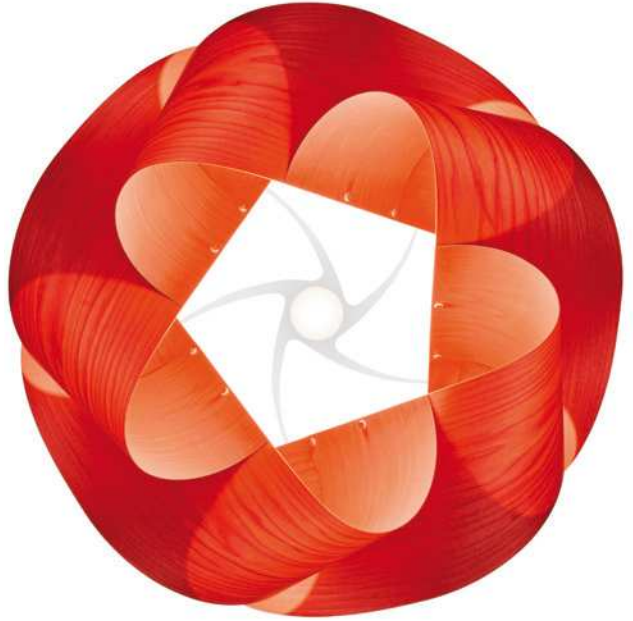

-
- **SWIRL - SMALL SUSPENSION**
20 Ivory White Wood Veneer.
"Mercado Little Spain". NY, USA.
Architect: Juli Capella.
Painter: Javier Marical.
Chef: José Andrés.



Totem

Totem is a veritable feast for the senses, a light whose proportions enliven a space with dramatic effect. Envisaged by designers Mariví Calvo and Burkhard Dämmer, Totem evolved from the clever amalgamation of Dämmer's Pod and Poppy pendants.

A sublime lighting structure, Totem has the emblematic air of a sacred object, a light whose shape and spirit are reflected in cultures worldwide. Available in three stacked variations, the Totem pendant diffuses warm light through the gaps in its wood veneer strips. As a physical entity, Totem's presence is impressive. Just as important, its spiritual quality is entirely unreserved.

- **TOTEM - SMALL & MEDIUM SUSPENSION**
20 Ivory White & 28 Blue Wood Veneer.
"Palau de Casavells". Girona, Spain.



Totem 3
Totem 4

Designed by:
Burkhard Dämmer

T
O
T
E

M

SMALL - TOTEM 3

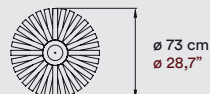
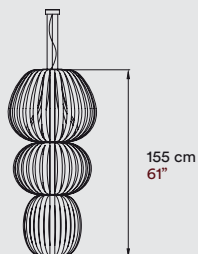

MEDIUM - TOTEM 4

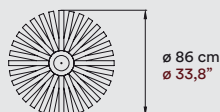
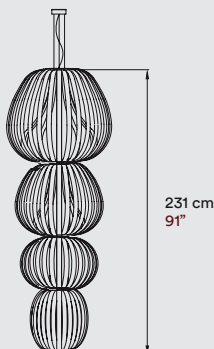

MATERIALS & COMPONENTS

3 or 4 Wood Veneer Shades

Metal Canopy

3 Steel Cables

2,5 m drop 8 ft drop

Electrical Cable

2,5 m drop 8 ft drop

LIGHT SOURCE

120 - 277V

LED Integrated

Dimmable 0-10V or Bluetooth

Class I 

120 - 277V



LED Integrated

Dimmable 0-10V & TRIAC

 US

FINISHES

WOOD VENEER

- | | | | |
|-------------------------------------------------------------------------------------|-------------------|-------------------------------------------------------------------------------------|--------------|
|  | 20 Ivory White |  | 26 Red |
|  | 21 Natural Cherry |  | 28 Blue |
|  | 22 Natural Beech |  | 29 Grey |
|  | 24 Yellow |  | 33 Pale Rose |
|  | 25 Orange |  | 34 Sea Blue |



- **TOTEM - MEDIUM SUSPENSION** | 21 Natural Cherry Wood Veneer.
"Apartment". Netherlands. Architect: Inge Bouman Interieur Architectuur.

THESIS



Thesis

Floor
Table
Wall

Designed by:
Ramón Esteve Estudio

Thesis is a table lamp and a floor lamp. It is a modern lamp whose companionship is close and intimate, casting a warm glow as you toil through the night, and by your side as you read or simply contemplate the day. Designed by Ramón Esteve, the Thesis lamp is well suited to quiet spaces: in a library, private study or cosy corner, its minimal form and clean lines are free from distraction.

In creating Thesis, a modest metallic base holds a wood veneer shade in its three prongs. Each prong contains an LED that diffuses light downwards, while casting a radiance that quietly highlights the natural timber veneer. In profile, is authoritative and introspective, a quiet light with a smart, introverted personality.

● **THESIS - FLOOR**

20 White Wood Veneer & Gold Metal Base.



● **THESIS - FLOOR**
20 White Wood Veneer & Matt Black Metal Base. "Casa en la Huerta". Valencia, Spain. Architect: Ramón Esteve Estudio.

FLOOR

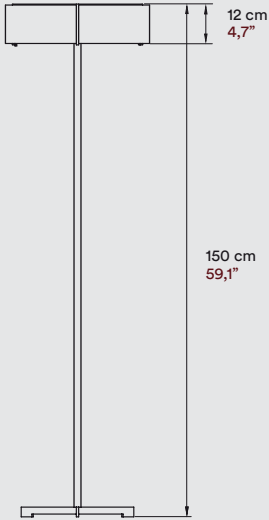

TABLE

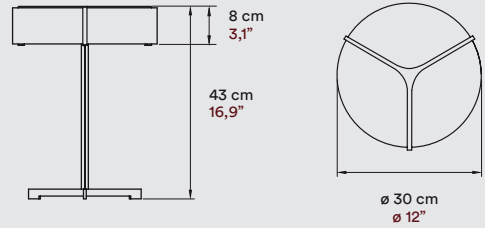

MATERIALS & COMPONENTS

Wood Veneer Shade

Metal Tripod, Stem & Base

Electrical Cable with Dimming Switch

FLOOR 185 cm 53"

TABLE 145 cm 57"

LIGHT SOURCE

230V

LED Integrated Dimmable

Class II  

120V

LED Integrated Dimmable



FINISHES

FLOOR WOOD VENEER SHADE





 20 Ivory White

TABLE WOOD VENEER SHADES

 20 Ivory White

 22 Natural Beech

 21 Natural Cherry

 29 Grey

METAL

 IV-Matt Ivory

 NI-Matt Nickel

 BK-Matt Black

 GD-Gold



● **THESIS - TABLE**
20 Ivory White Wood Veneer & Matt Black Metal Base.

● **THESIS - TABLE**
29 Grey Wood Veneer & Matt Black Metal Base.
Photo: 4000k. "Casa en la Huerta". Valencia, Spain.
Architect: Ramón Esteve Estudio.



● **THESIS - FLOOR & TABLE** | 20 White Wood Veneer & Matt Ivory Metal Base. "Casa en la Huerta". Valencia, Spain. Architect: Ramón Esteve Estudio.



SWING MECHANISM

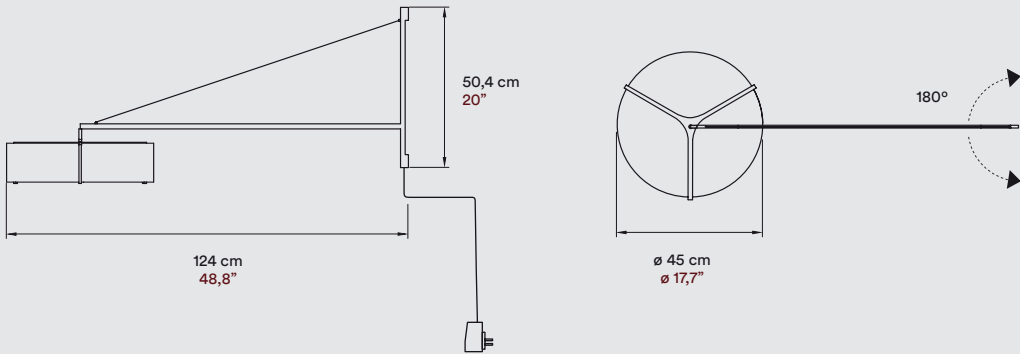

MATERIALS & COMPONENTS

Wood Veneer Shade

Metal Tripod & Structure

Electrical Cable with Dimming Switch
250 cm 98,4"

LIGHT SOURCE

230V
LED Integrated Dimmable

Class II  

120V
LED Integrated Dimmable

 US

FINISHES

WOOD VENEER

-  20 Ivory White
-  22 Natural Beech
-  21 Natural Cherry
-  29 Grey

METAL

-  IV-Matt Ivory
-  NI-Matt Nickel
-  BK-Matt Black
-  GD-Gold



● **THESIS - WALL**

29 Grey Wood Veneer & Matt Black Metal Structure. Photo: 4000k.
"Bouet" Restaurant. Valencia, Spain. Architect: Ramón Esteve Estudio.



X-Club

Supension
Wall
Ceiling

Hit the spot with the X-Club light designed by Burkhard Dämmer. With its curvy form, the X-Club emanates light with a sensual quality, akin to a three-dimensional kiss.

A wall, ceiling or suspension light, the X-Club confidently marks the spot wherever it is placed. Suited to numerous environments and contexts, from residential to retail, it is an especially impactful design when placed in clusters or rows. Light from the X-Club is both ambient and direct, with its wood veneer striking a prepossessing pose when illuminated.

• **X-CLUB - SUSPENSION**

24 Yellow & 26 Red Wood Veneer. Pharmacy, Switzerland.



CLUB

Designed by:
Burkhard Dämmer

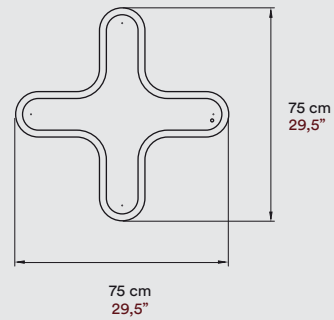
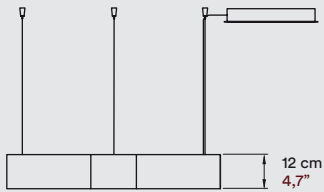

MATERIALS & COMPONENTS

Wood Veneer Shade

Top & Bottom Acrylic Diffuser

Metal Canopy

4 Steel Cables



2,5 m drop 8 ft drop

Electrical Cable

2,5 m drop 8 ft drop

FINISHES

WOOD VENEER

| | | | |
|-------------------------------------------------------------------------------------|-------------------|-------------------------------------------------------------------------------------|--------------|
|  | 20 Ivory White |  | 26 Red |
|  | 21 Natural Cherry |  | 28 Blue |
|  | 22 Natural Beech |  | 29 Grey |
|  | 24 Yellow |  | 33 Pale Rose |
|  | 25 Orange |  | 34 Sea Blue |

LIGHT SOURCE

120 - 277V

LED Integrated

Dimmable 0-10V, Bluetooth or DALI

Class I 

120 - 277V

LED Integrated

Dimmable 0-10V & TRIAC



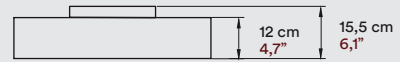
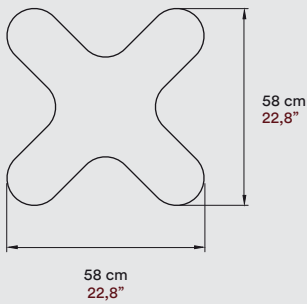

MATERIALS & COMPONENTS

Wood Veneer Shade

Frontal Acrylic Diffuser

Metal Back plate

LIGHT SOURCE

120 - 277V

LED Integrated

Dimmable 0-10V, Bluetooth or DALI

Class I CE

120 - 277V

LED Integrated

Dimmable 0-10V & TRIAC



FINISHES

WOOD VENEER

- | | |
|-------------------------------------------------------------------------------------------------------|--------------------------------------------------------------------------------------------------|
|  20 Ivory White |  26 Red |
|  21 Natural Cherry |  28 Blue |
|  22 Natural Beech |  29 Grey |
|  24 Yellow |  33 Pale Rose |
|  25 Orange |  34 Sea Blue |

LIFE
SIZE

SMELLY FANT

Smelly Fant

Designed by:
Isidro Ferrer & LZF Lab

Smelly Fant is the other Funny Farm animal we chose to convert into a light sculpture. Like all elephants, it has big ears, a trunk, even its own legs, and a body standing more than a meter and a half tall. To turn Isidro Ferrer's vision into a large-scale lamp, LZF has again drawn on the experience of the craftsman Manolo Martin.

Just as he did with Fish, Manolo used the "vareta" technique to shape the three spheres which constitute the body and the head of Elephant. Its luminous heart, at the centre of the sculpture, is diffused through a natural wood veneer internal lining.

-
- **SMELLY FANT - FLOOR**
20 Ivory White Wood Veneer.
"Palau de Casavells". Girona, Spain.



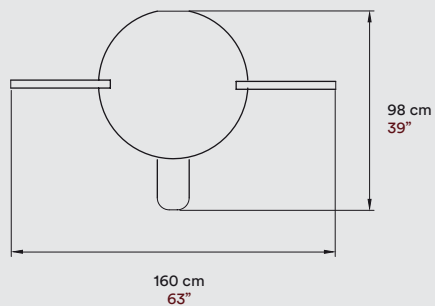
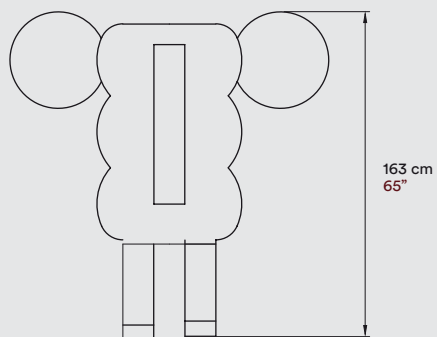

MATERIALS & COMPONENTS

Oak & Birch Wood



Wood Veneer Diffuser

Electrical Cable with Dimming Switch

200 cm 78,7"

LIGHT SOURCE

LED Integrated

Class II  

LED Integrated

FINISHES

WOOD VENEER

 20 Ivory White

AWARDS



Chicago



● **SMELLY FANT - FLOOR** | LZF "Dreams Book".
20 Ivory White Wood Veneer.
"Palau de Casavells". Girona, Spain.

FISH

The Walking Fish

Fish is modelled on one of the original pieces by Isidro Ferrer, a friendly fish with legs which has become one of the first large-scale light sculptures within the Funny Farm project. The carefully studied layout produces a captivating effect.

Designed by:
Isidro Ferrer & LZF Lab

- **THE WALKING FISH - FLOOR**
20 Ivory White Wood Veneer. "Palau de Casavells". Girona, Spain.



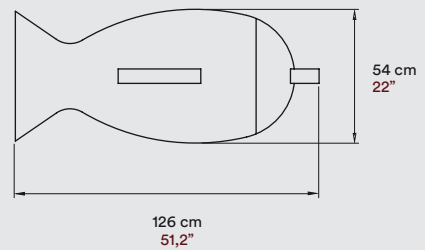
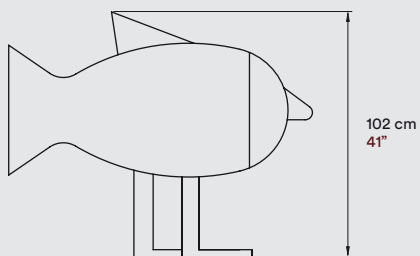

MATERIALS & COMPONENTS



Oak & Birch Wood

Wood Veneer Diffuser

Electrical Cable with Dimming Switch
200 cm 78,7"

LIGHT SOURCE

LED Integrated

Class II  

LED Integrated

242

FINISHES

WOOD VENEER

 20 Ivory White



-
- **THE WALKING FISH**
20 Ivory White Wood Veneer.

BIG BIRD

Big Bird

Designed by:
Isidro Ferrer & LZF Lab

As a new member of LZF's Life-Size family, Big Bird joins the happy adventures of Smelly Fant, Fish and Koi. Hovering vertically with fluttering wings, Big Bird has the agile appearance of a gentle hummingbird.

Created by the illustrator and designer Isidro Ferrer and built using a traditional craft technique called vareta, Big Bird is a masterly feat of wood craftsmanship. While light radiates from Big Bird's wooden plumage, a glass globe hangs from its beak, like a ball of glowing nectar.

With Big Bird, LZF is once again dreaming big, re-engineering the concept of what a lamp can be, in both shape and scale.

● **BIG BIRD VERTICAL - SUSPENSION**

Crafted Elm and Birchwood exterior, Interior Tulip Wood diffuser in 20 Ivory White.





• **BIG BIRD HORIZONTAL - SUSPENSION**

Crafted Elm and Birchwood exterior, Interior Tulip Wood diffuser in 20 Ivory White.





● **BIG BIRD HORIZONTAL - SUSPENSION** | Crafted Elm and Birchwood exterior, Interior Tulip Wood diffuser in 20 Ivory White.



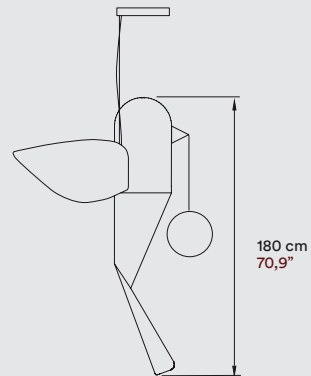
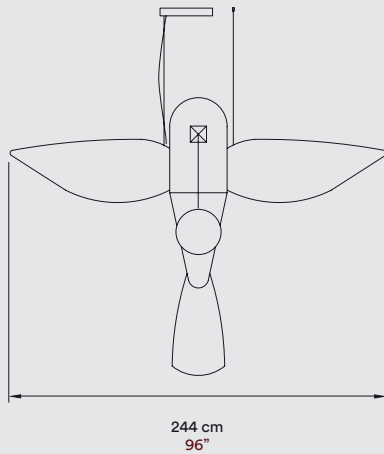

MATERIALS & COMPONENTS

Oak & Birch Wood

Wood Veneer Diffuser

Frosted Glass Ball

Metal Canopy

2 Steel Cables

5 m drop 16,5 ft drop

Electrical Cable

5 m drop 16,5 ft drop

FINISHES

WOOD VENEER

● 20 Ivory White

LIGHT SOURCE

120 - 277V

LED Integrated

Dimmable 0-10V, Bluetooth or DALI &

Bulb E27

Class I 

120 - 277V

LED Integrated Dimmable &

Bulb E26



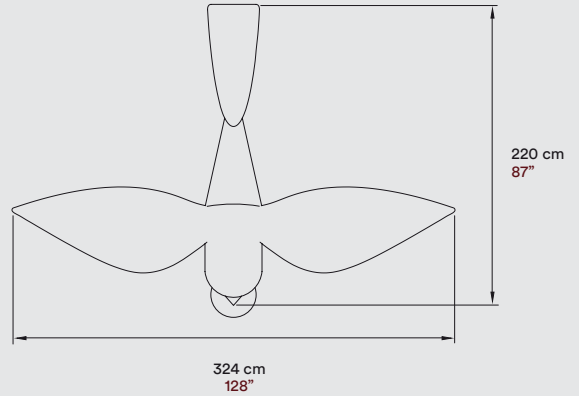
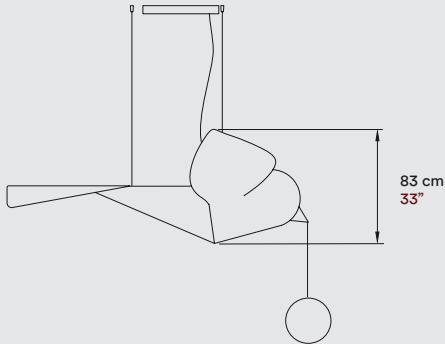

MATERIALS & COMPONENTS

Oak & Birch Wood

Wood Veneer Diffuser

Frosted Glass Ball

Metal Canopy

3 Steel Cables
5 m drop 16,5 ft drop

Electrical Cable
5 m drop 16,5 ft drop

FINISHES

WOOD VENEER

● 20 Ivory White

LIGHT SOURCE

120 - 277V
LED Integrated
Dimmable 0-10V, Bluetooth or DALI &
Bulb E27

Class I

120 - 277V
LED Integrated Dimmable &
Bulb E26



Koi

Designed by:
Inocuo The sign & LZF Lab

Part pendant, part sculpture, Koi is a dramatic and decorative light that appears as a surreal wood creature. Koi has an ethereal beauty: engendering a considerable sense of wonderment, its animated form captivates the eye. Cutting an imposing figure, it offers the perfect lighting climax.



• **KOI - SUSPENSION** | 20 Ivory White Wood Veneer. LZF "Dreams Book".

SMALL - KOGOI

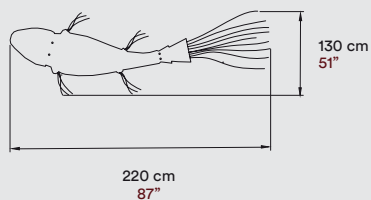
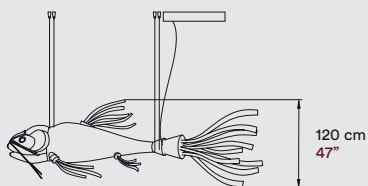

LARGE - KOI

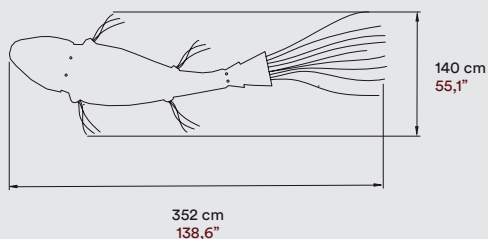
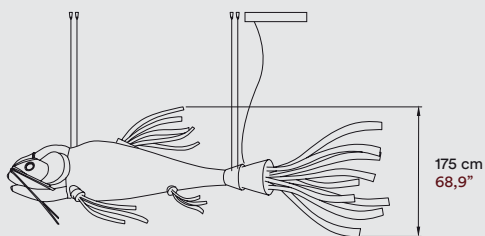

MATERIALS & COMPONENTS

Oak & Birch Wood

Wood Veneer Diffuser

Metal Canopy

4 Steel Cables

5 m drop 16,5 ft drop

Electrical Cable

5 m drop 16,5 ft drop

LIGHT SOURCE

120 - 277V

LED Integrated

Dimmable 0-10V, Bluetooth or DALI

Class I

120 - 277V

LED Integrated

Dimmable 0-10V



FINISHES

WOOD VENEER

20 Ivory White

22 Natural Beech

AWARDS



Chicago



● KOI - SUSPENSION | 22 Natural Beech Wood Veneer. "Kohakinho" Restaurant. Switzerland. Architect: Bruner Huber. Photography: FTFOTO.

FINISHES

NATURAL TIMBER VENEER



The mark of responsible forestry



Timberlite™

The dramatic effect of light passing through the wood veneer is the essence and hallmark of LZF. This important feature would not be possible without the application of our patented process in treating the raw natural veneer: the Timberlite® system.

This system, the result of LZF's research & development work, allows us to work with an extremely flexible, yet very resistant veneer, which can take on many shapes without breaking. In addition to all our veneers being FSC certified, thanks to the treatment, the wood used to fabricate our lamps maintains its natural qualities, adopting different nuances and hues over time.

**SOURCE
LIGHT
TEMPERATURE**

Choose your light temperature carefully, wood veneer colour can change radically depending on the colour temperature you use.

Recommended temperature LED for coloured LZF shades:

20- Ivory White (3000k-6400k)

21-Cherry, 22-Beech, 28-Blue, 29-Grey and 34 Sea Blue (4000k)

24-Yellow, 25-Orange, 26-Red and 33 Pale Rose (2700k-4000k)

21 Natural
Cherry
Off



21 Natural
Cherry
4000k

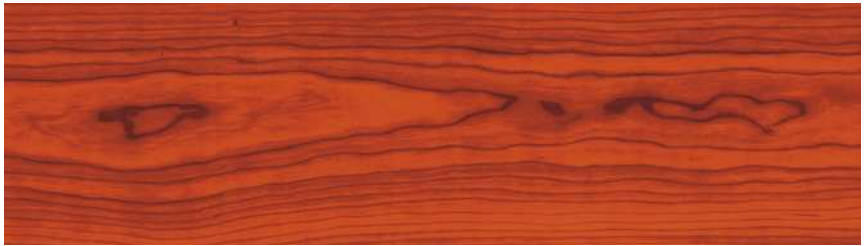

21 Natural
Cherry
3000k



21 Natural
Cherry
2700k

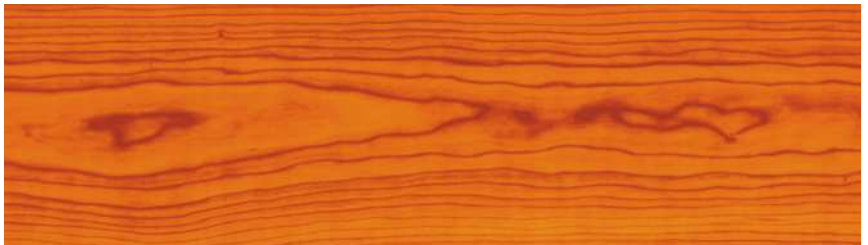

WOOD SHADE FINISHES

20.
Ivory White
Off



20.
Ivory White
On



21.
Natural
Cherry
Off



21.
Natural
Cherry
On

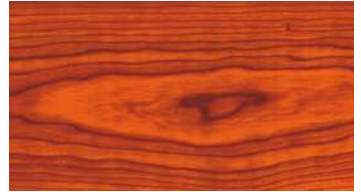

22.
Natural
Beech
Off



22.
Natural
Beech
On



24.
Yellow
Off



24.
Yellow
On

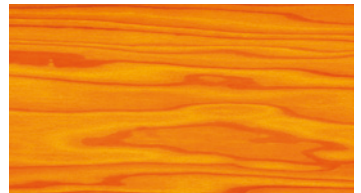

25.
Orange
Off



25.
Orange
On

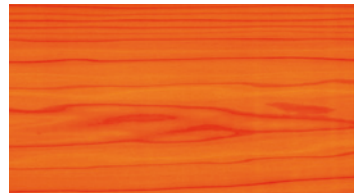

26.
Red
Off



26.
Red
On



28.
Blue
Off



28.
Blue
On

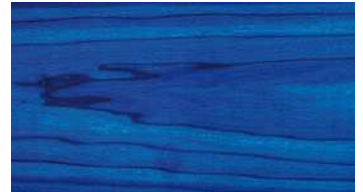

29.
Grey
Off



29.
Grey
On



33.
Pale Rose
Off



33.
Pale Rose
On



34.
Sea Blue
Off

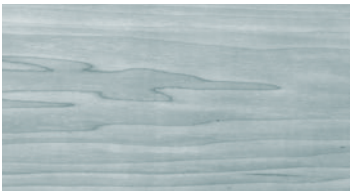

34.
Sea Blue
On

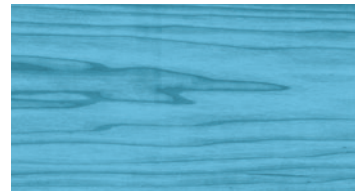

Please only use these reproductions as a guide.
Use LZF wood swatches to see the spectacular real effect of the illuminated veneers.

METAL FINISHES



For too many years things have been simply black and white, but life is made up of many shades and we have been wanting to create a more generous array of skin colours for our lights for quite sometime. This year we have wanted to offer you the choice of not just picking your shade colour but also the colour of the metallic finish that accompanies it. Matt tones or coloured reflections in satin nickel finishes provide a whole new range of choice when selecting your lamp.

BK
Matt Black

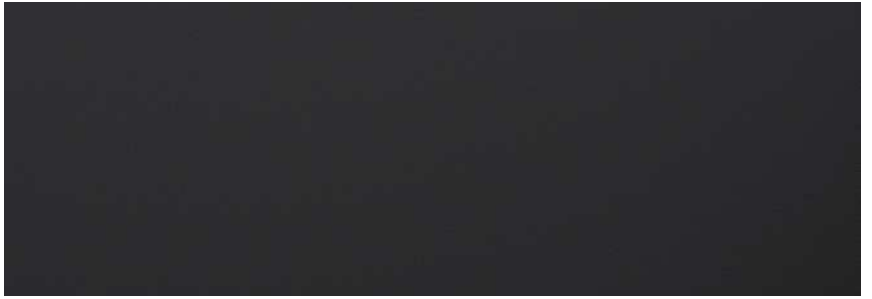

NI
Matt Nickel



GD
Gold



IV
Matt Ivory

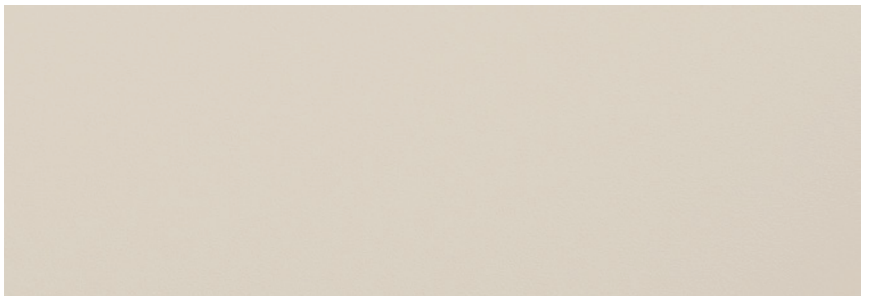

DESIGNERS

RAMÓN ESTEVE ESTUDIO

Black Note
Thesis



MUT DESIGN

Lens
Tomo



MARIVÍ CALVO

Candelabro
Cosmos
Gea
Guijarro
Oh!Line



RAY POWER

Air
Escape
Hi-Collar
Link
Lola
New Wave
Nut
Swirl



YONOH CREATIVE STUDIO

Banga
Chou
Mini Chou
Pleg



BURKHARD DÄMMER

Cuad
Dandelion
I-Club
I-Line
Oh!Line
Pod & Poppy
Totem
X-Club



ISIDRO FERRER

Big Bird
Smelly Fant
The Walking Fish



**LUIS ESLAVA
STUDIO**

Agatha



OSKAR CEREZO

Carambola
Saturnia



**JAVIER HERRERO
STUDIO**

Raindrop



**MIGUEL
HERRANZ**

MiniMikado
Orbit



RQR STUDIO

Domo



REMEDIOS SIMÓN

Spiro



BUROJET

Stitches



CREDITS

Project Director

Mariví Calvo

Photo Art Direction

Mariví Calvo

Writer

Gerard McGuickin

Photographers

Santiago Relanzón

Ángel Segura

Klunderbie

Jara Varela

Cualiti

Maria Mira

Graphic Design

Lo Siento

Lzf Graphic Design

Miriam Castellano

Printed By

Logik Graphics, 2021

All our thanks to

Pablo Gironés

Ramón Esteve



In the USA, LZF is exclusively distributed by:

IMPORT&ENT

IMPORT&ENT LLC. 2750 NW 84th Ave. Doral, FL 33122. T (404) 382-9023

